

MAVOLOG PRO

Power Quality Analyzer

3-349-790-03
2/8.18



Security Advices and Warnings

Please read this chapter carefully and examine the equipment thoroughly for potential damage which might have arisen during transport. This chapter will help you to become familiar with the Quality Analyzer **MAVOLOG PRO** before you continue to install, energize and work with it.

This chapter deals with important information and warnings that should be considered for safe installation and handling with a device in order to assure its correct use and continuous operation.

Everyone using the product should become familiar with the contents of chapter »Security Advices and Warnings«.

If equipment is used in a manner not specified by the manufacturer, the protection provided by the equipment may be impaired.

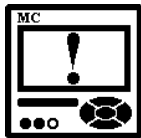

PLEASE NOTE

This booklet contains instructions for installation and use of Quality Analyser **MAVOLOG PRO**. Installation and use of a device also includes handling with dangerous currents and voltages therefore should be installed, operated, serviced and maintained by qualified personnel only. GOSSEN METRAWATT assumes no responsibility in connection with installation and use of the product. If there is any doubt regarding installation and use of the system in which the device is used for measuring or supervision, please contact a person who is responsible for installation of such system.

Before switching the device ON





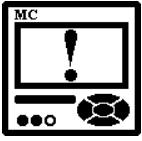

Check the following before switching on the device:

- Nominal voltage,
- Supply voltage,
- Nominal frequency,
- Voltage ratio and phase sequence,
- Current transformer ratio and terminals integrity,
- Protection fuse for voltage inputs (recommended maximal external fuse size is 6 A)
- Integrity of earth terminal
- Proper connection and voltage level of I/O modules

**WARNING!****Feature A01 only (no longer available):**

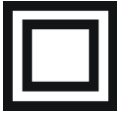
Auxiliary power supply can be LOW range (19 ... 70 V_{DC}, 48 ... 77 V_{AC}).
Connecting device with LOW power supply to higher voltage will cause
device malfunction. Check device specification before turning it on!

Used symbols on devices' housing and labels

	<p>DANGER indicates proximity of hazardous high voltage, which might result in serious injury or death if not handled with care</p>
	<p>WARNING indicates situations where careful reading of this manual is required and following requested steps to avoid potential injury is advised</p>
	<p>Double insulation in compliance with the EN 61010-1: 2010 standard.</p>
	<p>Functional ground potential. Note: This symbol is also used for marking a terminal for ground potential, which is used as a fourth voltage input channel.</p>
	<p>Compliance of the product with directive 2012/19/EU, as first priority, the prevention of waste electrical and electronic equipment (WEEE), and in addition, the reuse, recycling and other forms of recovery of such wastes so as to reduce the disposal of waste. It also seeks to improve the environmental performance of all operators involved in the life cycle of electrical and electronic equipment.</p>
	<p>Compliance of the product with European CE directives.</p>

Device Return and Environmentally Compatible Disposal

The instrument is a category 9 product (monitoring and control instrument) in accordance with ElektroG (German Electrical and Electronic Device Law). This device is subject to the RoHS directive. Furthermore, we make reference to the fact that the current status in this regard can be accessed on the Internet at www.gossenmetrawatt.com by entering the search term WEEE.

We identify our electrical and electronic devices in accordance with WEEE 2012/19/EU and ElektroG with the symbol shown above per DIN EN 50419.

These devices may not be disposed of with the trash. Please contact our service department regarding the return of old devices, see page 182.

Contents

BASIC DESCRIPTION AND OPERATION	7
INTRODUCTION	8
DESCRIPTION OF THE DEVICE	10
PURPOSE AND USE OF THE DEVICE	12
MAIN FEATURES, SUPPORTED OPTIONS AND FUNCTIONALITY	13
CONNECTION	17
INTRODUCTION	18
MOUNTING	20
ELECTRICAL CONNECTION	21
CONNECTION OF AUX. POWER SUPPLY	31
FIRST STEPS	32
BASIC CONCEPTS	33
INSTALLATION WIZARD	33
DISPLAY OF DEVICE INFO	36
SETTINGS	37
INTRODUCTION	38
MAVO-VIEW SOFTWARE	38
GENERAL SETTINGS	46
CONNECTION	54
SERIAL COMMUNICATION	56
USB COMMUNICATION	58
ETHERNET COMMUNICATION	59
DISPLAY	63
SECURITY	65
ENERGY	67
I/O MODULES	72
ALARMS	83
INTERNAL MEMORY	88
CONFORMITY OF VOLTAGE WITH EN 50160 STANDARD	93
RESET OPERATIONS	99
SETTINGS AND MEMORY CARD	101

MEASUREMENTS	106
INTRODUCTION	107
SELECTION OF AVAILABLE QUANTITIES	109
EXPLANATION OF BASIC CONCEPTS	113
CALCULATION AND DISPLAY OF MEASUREMENTS	115
PRESENT VALUES	116
MIN/MAX VALUES	122
ALARMS	124
HARMONIC ANALYSIS	126
PQ ANALYSIS	130
COMMUNICATION MODES	139
PULL COMMUNICATION MODE	140
PUSH COMMUNICATION MODE	141
TECHNICAL DATA	144
ACCURACY	145
INPUTS	147
CONNECTION	148
COMMUNICATION	148
I/O MODULES	149
SAFETY	151
OPERATING CONDITIONS	152
DIMENSIONS	153
APPENDIX A: MODBUS COMMUNICATION PROTOCOL	155
APPENDIX B: DNP3 COMMUNICATION PROTOCOL	167
APPENDIX C: EQUATIONS	176
APPENDIX D: XML DATA FORMAT	180

Basic Description and Operation

The following chapter presents basic information about **MAVOLOG PRO** Quality Analyser required to understand its purpose, applicability and basic features connected to its operation.

Besides that, this chapter contains navigational tips, description of used symbols and other useful information for understandable navigation through this manual.

In this chapter you will find:

INTRODUCTION	8
DESCRIPTION OF THE DEVICE	10
PURPOSE AND USE OF THE DEVICE	12
MAIN FEATURES, SUPPORTED OPTIONS AND FUNCTIONALITY	13

Introduction

Regarding the options of a Quality Analyser, different chapters should be considered since it might vary in functionality and design. More detailed description of device functions is given in chapter *Main Features, supported options and functionality, page 13*.



Quality Analyser **MAVOLOG PRO** is available in housing for panel mounting. Specifications of housing and panel cut out for housing is specified in chapter *Dimensions on page 153*.

Description of symbols

In different chapters or tables different symbols may appear in User's Manual. According to the position of symbols, they have different meaning.

Subchapter

Symbols next to the subchapters indicate accessibility of functions described. Accessibility of functions is indicated with the following symbols:

-  Function accessible via communication (MAVO-View software)
-  Function accessible via navigation keys on the device front side

Tables

Supported functions and measurements are listed in tables. Symbols in tables indicate support of enabled functions for different connection schemes. Additionally a legend is placed below table of used symbols. Meaning of symbols is:

- Function is supported
- × Function is not supported
- Symbol meaning varies and is described in the legend below the table

Abbreviations

Abbreviations are explained within the text where they appear the first time. Most common abbreviations and expressions are explained in the following table:

Table 1: List of common abbreviations and expressions

Term	Explanation
RMS	Root Mean Square value
Flash	Type of a memory module that keeps its content in case of power supply failure
Ethernet	IEEE 802.3 data layer protocol
MODBUS / DNP3	Industrial protocol for data transmission
Memory card	Multimedia memory card. Type MMC and SD supported.
MAVO-View	Setting Software for GOSSEN METRAWATT instruments
PA total	Power Angle calculated from total active and apparent power
PA_{phase}	Angle between fundamental phase voltage and phase current
PF_{phase}	Power factor, calculated from apparent and active power (affected by harmonics)
THD (U, I)	Total harmonic distortion
MD	Max. Demand; Measurement of average values in time interval
FFT graphs	Graphical display of presence of harmonics
Harmonic voltage – harmonic	Sine voltage with frequency equal to integer multiple of basic frequency
InterHarmonic voltage – interharmonic	Sine voltage with frequency NOT equal to integer multiple of basic frequency
Flicker	Voltage fluctuation causes changes of luminous intensity of lamps, which causes the so-called flicker
RTC	Real Time Clock
Sample factor	Defines a number of periods for measuring calculation on the basis of measured frequency
M_p – Average interval	Defines frequency of refreshing displayed measurements
Hysteresis [%]	Percentage specifies increase or decrease of a measurement from a certain limit after exceeding it.
IRIG-B	Serial Inter-range instrumentation group time code
GPS	Satellite navigation and time synchronisation system
PO	Pulse output module
TI	Tariff input module
RO	Relay output module
BO	Bistable alarm output module
AO	Analogue output module
DI	Digital input module
PI	Pulse input module
AI	Analogue input module
WO	Status (watchdog) module – for supervision of proper operation

Description of the device

MAVOLOG PRO Quality Analyser is a comprehensive device intended for permanent monitoring of power quality from its production (especially renewable), transmission, distribution to final consumers, who are most affected by insufficient quality of voltage. It is mostly applicable in medium and low voltage markets.

Lack of information about supplied quality of voltage can lead to unexplained production problems and malfunction or even damage to equipment used in production process. Therefore, this device can be used for utility purposes (evaluation against standards) as well as for industrial purposes (e.g. for monitoring supplied power quality).

Appearance

- 1- Graphical LCD
- 2- Navigation keyboard
- 3- A slot with a cover for memory card
- 4- General operation LED indicators (card/com./alarm)
- 5- I/O status LED indicators



Graphical LCD

A graphical LCD with back light is used for high resolution of displayed measuring quantities and for a display of selected functions when setting the device.

Navigation keyboard

The "OK" key is used for confirming the settings, selecting and exiting the display. Direction keys are used for shifting between screens and menus.

A slot with a cover Memory card

A Quality Analyser is provided with a slot for a full size MMC or SD card that is used for data transfer from the internal memory, device setting and software upgrading. A slot protection cover for the card prevents penetration of humidity and dust into device.

LED indicators

There are two types of LED indicators positioned on the front panel. General operation LED indicators and I/O status LED indicators.

General operation LED indicators warns of a certain state of the device. A left (red) indicator indicates the card activity and that it should not be pulled out. A middle (green) one is blinking when transmitting MC data via communication. A right (red) one is blinking when the condition for the alarm is fulfilled.

I/O state LED indicators are in operation when additional Modules A and/or B are built in and they have functionality of Digital input or Relay output. They are indicating the state of a single I/O. Red LED is lit when:

- Relay output is activated
- Signal is present on Digital input

Purpose and use of the device

MAVOLOG PRO Quality Analyser performs measurements in compliance with regulatory requested standard EN 61000-4-30 and evaluates recorded parameters for analysis according to parameters defined in European supply quality standard EN 50160:2011.

Moreover device stores measurements and quality reports in internal memory for further analysis over recorded measurements. From multiple devices installed on different locations, user can gain the overall picture of system behaviour. This can be achieved with regard to its accurate internal real time clock and wide range of synchronization sources support, which assure accurate, time-stamped measurements from dislocated units.

All required measurements, weekly PQ reports and alarms can also be stored locally in an internal memory. Stored data can be then transferred to a memory card or accessed through communication for post analysis by means of MAVO-View software.

The internal memory capacity enables storing of more than 170,000 variations of the measurements from the standard values, which enables finding eventual reasons for the problems in network. Limits and required quality in a monitored period can be defined for each monitored characteristic. The following characteristics are measured and recorded:

Table 2: Power Quality indices as defined by EN 50160

Phenomena	PQ Parameters
Frequency variations	Frequency distortion
Voltage variations	Voltage fluctuation Voltage unbalance
Voltage changes	Rapid voltage changes Flicker
Voltage events	Voltage dips Voltage interruptions Voltage swells
Harmonics & THD	THD Harmonics Inter-harmonics Signalling voltage

Main Features, supported options and functionality

MAVOLOG PRO Quality Analyser is a perfect tool for monitoring and analysing medium or low voltage systems in power distribution and industrial segments. It can be used as a standalone PQ monitoring device for detection of local PQ deviations. For this purpose it is normally positioned at the point-of-common-coupling (PCC) of small and medium industrial and commercial energy consumers to monitor quality of delivered electric energy or at medium or low voltage feeders to monitor, detect and record possible disturbances caused by (unauthorized) operation of consumers.

User can select different hardware modules that can be implemented in device. Wide range of variants can cover practically every user's requirements.

MAVOLOG PRO Quality Analyser is a compact, user friendly and cost effective device that offers various features to suit most of the requirements for a demanding power system management:

- *PQ analysis in compliance with EN 50160 with automatic report generation*
- *High accuracy in compliance with Class A (0.1%) EN61000-4-30*
- *Automatic range selection of 4 current and 4 voltage channels (max. 12.5 A and 1000 Vrms) with 32 kHz sampling rate*
- *Recording up to 128 measurands, 32 adjustable alarms, anomalies and quality reports in the internal memory*
- *MODBUS and DNP3 communication protocols*
- *Support for effective sub metering applications (comprehensive counters settings, tariff and cost management)*
- *Support for GPS, IRIG-B (modulated and digital) and NTP real time synchronisation*
- *Up to 20 inputs and outputs*
- *Multilingual support*
- *User-friendly setting and evaluation software, MAVO-View*
- *CE certification*
- *PSL Class A certificate*

General hardware Features

Default / Optional

General

Class A measuring accuracy according to EN 61000-4-30

●

Voltage auto range up to 1000V_{p-PRMS}

●

Current auto range up to 12.5 A

●

4 voltage and 4 current channels with 32 μs sampling time

●

Universal power supply type High or type Low

● / ○

Two independent communication ports (see data below)

○

Support for GPS, IRIG-B and NTP real time synchronisation

● / ● / ○

Up to 20 additional inputs and outputs (see data below)

○

Internal flash memory (8MB)

●

Real time clock (RTC)

●

standard 144 mm DIN square panel mounting

●

Front panel

Graphical LCD display with back light

●

LED indicator (card/com./alarm)

●

I/O status LED indicator

●

SD memory card slot for data transfer

●

Control keys on front panel (5 keys)

●

Communication

COM1: Ethernet +USB / USB / Serial (RS232/485)

○ / ○ / ●

COM2: Serial (RS232/ RS485 on slot C if other synchronisation modes are in use)

●

- – Function is supported (default)
- – Optional (to be specified with an order)

General hardware Features

Default / Optional

General hardware Features	Default / Optional
Input and output modules	
Input / output module 1 2xAO / 2xAI / 2xRO / 2xPO / 2xPI / 2xTI / 1xBO / 2xDI / WO+RO	o/o/o/o/o/o/o/o
Input / output module 2 2xAO / 2xAI / 2xRO / 2xPO / 2xPI / 2xTI / 1xBO / 2xDI / WO+RO	o/o/o/o/o/o/o/o
Auxiliary input / output module A I/O A (1-8) DI / RO	o / o
Auxiliary input / output module B I/O B (1-8) DI / RO	o / o
Synchronisation module C I/O C GPS + 1pps / IRIG-B / COM2	● / ● / ●

- Function is supported (default)
- Optional (to be specified with an order)

- PO Pulse output module
- TI Tariff input module
- RO Relay output module
- BO Bistable relay output module
- AO Analogue output module
- DI Digital input module
- PI Pulse input module
- AI Analogue input module – U, I or R (PT100/1000)
- WO Status (watchdog) module – for supervision of proper operation

General software Features

Default / optional

Setup wizard	•
Wrong connection warning	•
Custom screen settings (3 user defined screens on LCD)	•
Demonstration screen cycling	•
Programmable refresh time	•
MODBUS and DNP3 communication protocols	•
Tariff clock	•
MD calculation (TF, FW, SW)	•
Wide frequency measurement range 16 – 400 Hz	•
Programmable alarms (32 alarms)	•
Alarms recording	•
Measurements recording (128 quantities)	•
Measurements graphs (time / FFT)	•
Evaluation of voltage quality in compliance with EN 50160	•
Real time clock synchronisation (GPS/IRIG-B/NTP)	•

- Function is supported (default)
- Optional (to be specified with an order)

CONNECTION

This chapter deals with the instructions for Quality Analyser connection. Both the use and connection of the device includes handling with dangerous currents and voltages. Connection shall therefore be performed ONLY a by a qualified person using an appropriate equipment. GOSSEN METRAWATT does not take any responsibility regarding the use and connection. If any doubt occurs regarding connection and use in the system which device is intended for, please contact a person who is responsible for such installations.

In this chapter you will find:

INTRODUCTION	18
MOUNTING	20
ELECTRICAL CONNECTION	21
CONNECTION OF INPUT/OUTPUT MODULES	23
COMMUNICATION CONNECTION	27
CONNECTION OF REAL TIME SYNCHRONIZATION MODULE C	29
CONNECTION OF AUX. POWER SUPPLY	31

Introduction

A person qualified for installation and connection of a device should be familiar with all necessary precaution measures described in this document prior to its connection.

Contents

Contents and size of a packaging box can slightly vary depending on type of consignment.

Single device shipment or a very small quantity of devices is shipped in a larger cardboard box, which offers better physical protection during transport. This type of contents contains:

- **MAVOLOG PRO Quality Analyser**
- Fixation screws
- Pluggable terminals for connection of inputs, aux. Power supply and I/O modules
- CD with full version of this document, installation of setting software MAVO-View, required drivers for USB (if device is equipped with USB communication)
- Short installation manual

When larger amount of devices is sent they are shipped in a smaller cardboard box for saving space and thus reducing shipment costs. This type of contents contains:

- **MAVOLOG PRO Quality Analyser**
- Fixation screws
- Pluggable terminals for connection of inputs, auxiliary power supply and I/O modules
- Short installation manual

This document and settings software MAVO-View can also be found on our web page www.gossenmetrawatt.com.

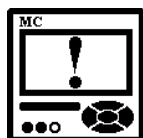

CAUTION

Please examine the equipment carefully for potential damage which might arise during transport!

Before use

Before use please check the following:

- Nominal voltage ($U_{P-Pmax} = 1000V_{ACrms}$; $U_{P-Nmax} = 600V_{ACrms}$),
- Supply voltage (type HIGH or type LOW),
- Nominal frequency,
- Voltage ratio and phase sequence,
- Current transformer ratio and terminals integrity,
- Protection fuse for voltage inputs (recommended maximal external fuse size is 6 A)
- Integrity of earth terminal
- Proper connection and voltage level of I/O modules

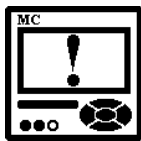

WARNING

Wrong or incomplete connection of voltage or other terminals can cause non-operation or damage to the device.

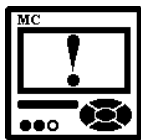

WARNING

It is imperative that terminal 12 which represents fourth voltage measurement channel is connected to earth pole ONLY. This terminal should be connected to EARTH potential at all times! This input channel is used only for measuring voltage between neutral end earth line.

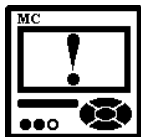

CAUTION

Aux. supply inrush current can be as high as 20A for short period of time (<1 ms). Please choose an appropriate MCB for connection of auxiliary supply.



PLEASE NOTE

After connection, settings have to be performed via a keyboard on the front side of the device that reflect connection of device to voltage network (connection mode, current and voltage transformers ratio...). Settings can also be done via communication or a memory card.

Mounting

MAVOLOG PRO Quality Analyser is intended only for panel mounting. Pluggable connection terminals allow easier installation and quick replacement should that be required.

This device is not intended for usage as portable equipment and should be used only as a fixed panel mounted device.

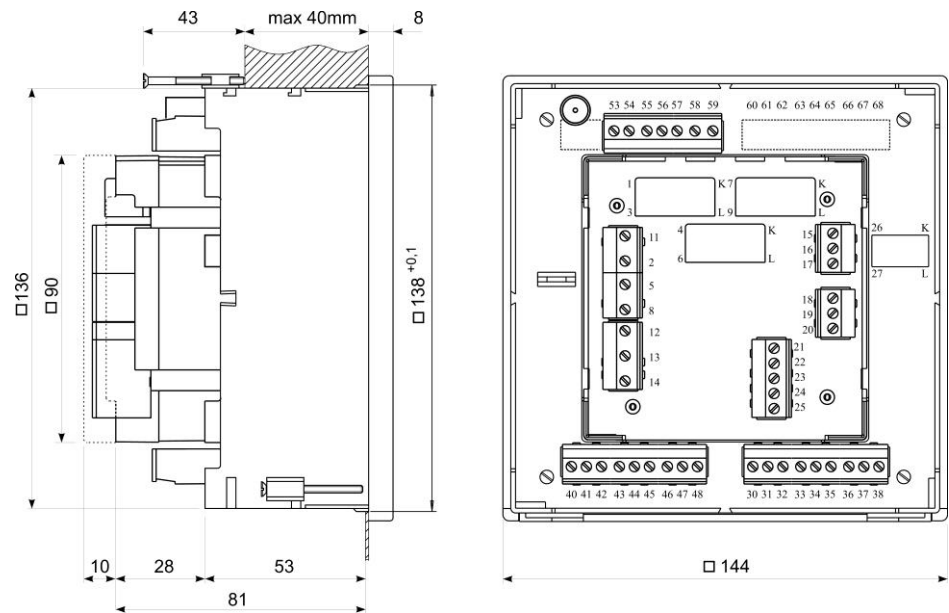

Figure 1: Dimensional drawing and rear connection terminals position

Recommended panel cut out is:

138 x 138 mm + 0.8

Please remove protection foil from the screen.

Electrical connection

Voltage inputs of a device can be connected directly to low-voltage network or via a voltage measuring transformer to a medium or high voltage system.

Current inputs of a device are led through a hole in current transformers to allow uninterrupted current connection. Connection to network is performed via a corresponding current transformer.

Choose corresponding connection from the figures below and connect corresponding voltages and currents. Information on electrical consumption of current and voltage inputs is given in a chapter I/O modules on page 72.

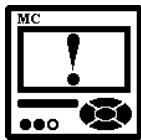

CAUTION

For accurate operation and to avoid measuring signal crosstalk it is important to avoid driving voltage measuring wires close to current measuring transformers.

**Connection 1b (1W);
Single-phase
connection**

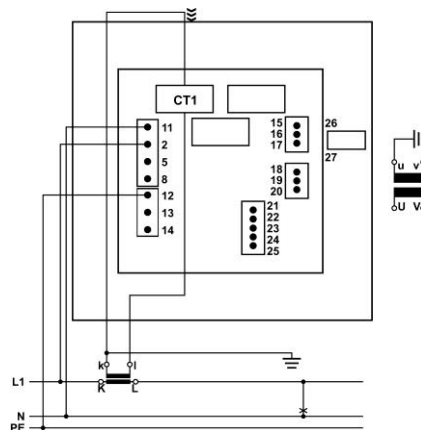

**Connection 3b (1W3)
Three-phase – three-
wire connection with
balanced load**

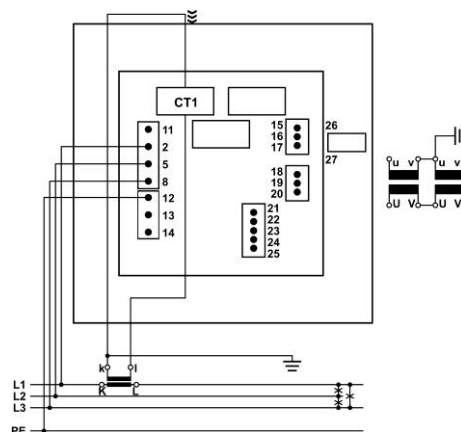

Connection 3u (2W3)
Three-phase – three-
wire connection with
unbalanced load

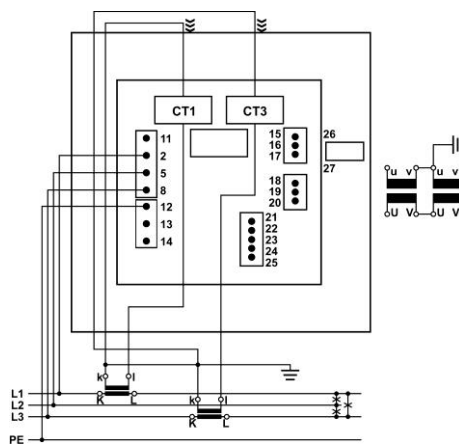

Connection 4b (1W4)
Three-phase – four-
wire connection with
balanced load

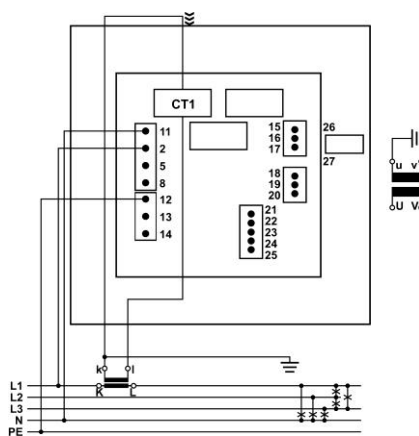

Connection 4u (3W4)
Three-phase – four-
wire connection with
unbalanced load

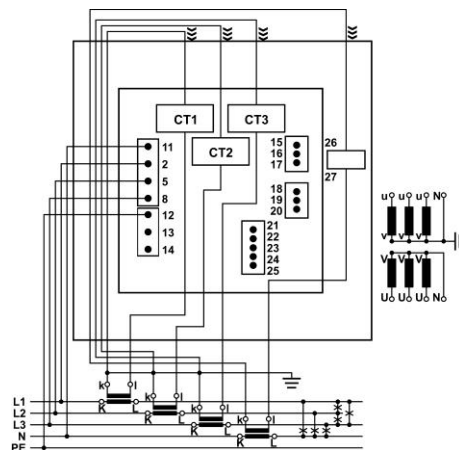

PLEASE NOTE

Examples of connections are given for device with built in two input / output modules and RS232 / RS485 communication. Connection does not depend on the number of built-in modules and communication, and is shown on the device label.

Connection of input/output modules

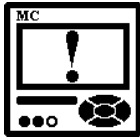

WARNING

Check the module features that are specified on the label, before connecting module contacts. Wrong connection can cause damage or destruction of module and/or device.



PLEASE NOTE

Examples of connections are given for device with built in two input / output modules and RS232 / RS485 communication. Connection does not depend on the number of built-in modules and communication, and is shown on the device label.

Connect module contacts as specified on the label. Examples of labels are given below and describe modules built in the device. Information on electrical properties of modules is given in a chapter I/O modules on page 72.

I/O module 1 and 2 (terminal numbers 15-20) – output options

I/O 1/2		
2 x Relay output		
230 V DC/AC	1 -	15
	+/~	
	-/~	16
1000 mA	2 -	
	+/~	17

Alarm (relay) output module with two outputs.

I/O 3/4		
1 x Bistable al. output		
230 V DC/AC	+/~	18
	-/~	19
1000 mA	+/~	20

Bistable alarm output module; keeps the state also in case of device power supply failure.

I/O 1/2		
2 x Pulse output		
40 V DC/AC	1 -	15
	+/~	
	-/~	16
30 mA	2 -	
	+/~	17

Pulse output (solid state) module with two pulse outputs for energy counters.

I/O 1/2		
Watchdog / Relay output		
230 V DC/AC	1 -	15
	+/~	
	-/~	16
1000 mA	2 -	
	+/~	17

Status (watchdog) output module enables proper device operation supervision on one output (WD) and alarm output functionality on the other.

I/O 1/2		
2 x Analogue output		
0...20 mA	1 +	15
	-	16
R _{max} =150 Ω	2 -	
	+	17

Analogue output module with two analogue outputs (0...20mA), proportional to measured quantities.

I/O module 1 and 2 (terminal numbers 15-20) – input options

I/O 1/2		
2 x Tariff input		
230 V AC	1 ~	15
± 20%	~	16
	2 ~	17

Tariff input module with two tariff inputs for changeover between up to four tariffs.

I/O 1/2		
2 x Digital input		
230 V DC/AC	1 +/~	15
± 20%	-/~	16
	2 +/~	17

Digital input module with two digital inputs enables reception of pulse signals.

I/O 1/2		
2 x Pulse input		
5...48 V DC	1 +	15
	-	16
	2 +	17

Pulse input module enables reception of pulses from various counters (water, gas, heat, flow

I/O 1/2		
2 x Analogue input		
-20...0...20 mA	1 +	15
	-	16
	2 +	17

Analogue input module enables measurements of DC U, I, R or temp. (PT100, PT1000) values from external sources. Modules have different hardware, so programming is possible within one quantity.

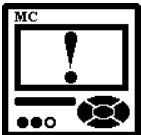

WARNING

If only one resistance-temperature analogue input is used, the other must be short-circuited.

Auxiliary I/O module A and B – output options

I/O B		8 x Relay output							
230 V DC/AC		100 mA							
C	1-/~	2-/~	3-/~	4-/~	5-/~	6-/~	7-/~	8-/~	
	+/~	+/~	+/~	+/~	+/~	+/~	+/~	+/~	
	40	41	42	43	44	45	46	47	48

Digital output relay module with eight digital outputs enables alarm functionality.

Auxiliary I/O module A and B – input options

I/O A		8 x Digital input							
230 V DC/AC		± 20%							
C	1 -/~	2 +/~	3 +/~	4 +/~	5 +/~	6 +/~	7 +/~	8 +/~	
	30	31	32	33	34	35	36	37	38

Digital input module with eight digital inputs enables reception of digital signals.

Synchronisation module C

I/O C	
IRIG-B	
1PPS	53
RS485	A 54
	B 55
	Rx 56
MODEM	↓ 57
	Tx 58
+5V	59

Synchronisation module is equipped with support for two different synchronisation methods IRIG-B and GPS modem.

When modulated IRIG-B signal is used it should be connected to BNC terminal. When level-shift IRIG-B signal is used it should be connected to 1PPS terminal.

In case of GPS modem, 1pps signal should be connected to 1PPS terminal and serial RS232 signal should be connected to RS232 terminals.

When IRIG-B (modulated or level-shift) or 1PPS signal is used for time synchronisation serial communication interface (RS232 or RS485) can be used as a devices' secondary communication port (COM2)



PLEASE NOTE

Communication port on Module C is primarily dedicated to receive serial coded date and time telegram from a GPS receiver in order to synchronise internal real time clock (RTC). When other methods are used for synchronising RTC this communication port can be used as a secondary general purpose communication port.

Please note that either RS232 or RS485 should be used and not both at a time. Connector terminals that are not used should remain unconnected otherwise the communication could not work properly.

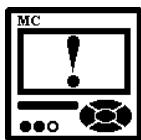

CAUTION

RTC synchronisation is essential part of Class A instrument. If no proper RTC synchronisation is provided device operates as Class S instrument.

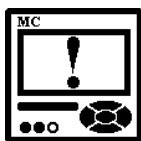

CAUTION

Max. consumption of +5V supply terminal is 100mA. When GPS with consumption greater the 100mA is used it is advisable to use external power supply.

Memory Card

MAVOLOG PRO Quality Analyser is equipped with a front panel slot for a SD memory card that supports capacity up to 2 GB.

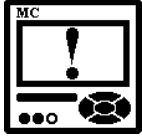

CAUTION

When memory slot is not used it should be covered with attached cover to avoid penetration of dust and small objects.

Memory card is useful for transferring stored data and performing other system operations (downloading settings, firmware update) when device is not connected to communication.

Memory card allows different operations. Immediately after insertion of a memory card devices' menu changes to show memory card options

```
SD card
SD info
Save data
Save settings
Load settings
Software update
← Main menu
```

Transferring data stored in internal memory

All data (readings, alarms, PQ reports and details), which are stored in internal memory can be transferred to a memory card.



PLEASE NOTE

Measurements cannot be directly recorded to a memory card. Only data previously stored in internal memory can be transferred to a memory card.

Upload and download settings

This is a very convenient way of programming devices. Settings can be manually programmed once and stored to a memory card by *Upload settings*. Using that memory card more devices can be programmed very fast with identical settings.

Firmware update

When new features are added or when certain fixes should be implemented it is necessary to update devices' firmware. This can again be performed fastest by using memory card. New firmware should be transferred to a memory card from computer once. After that multiple devices can be updated only with memory card.

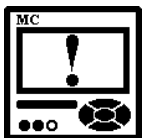

CAUTION

During firmware update aux. power supply **must not** be interrupted.

Communication connection

Primary communication interface (COM1) type is normally specified when placing an order. Device can support several types of communication:

- serial RS232/ 485 communication designed as a pluggable 5-pole screw terminal connector,
- Ethernet communication designed as standard RJ-45 terminal and USB communication designed as standard USB-B type terminal
- Single USB communication designed as standard USB-B type terminal



PLEASE NOTE

When connecting serial communication please note that only RS232 or RS485 should be used and not both at a time. Connector terminals that are not used should remain unconnected otherwise the communication could not work properly.

Beside primary communication port the device has built in a secondary communication port (COM2) as a part of a real time synchronisation module C. Its operation is described in a chapter referring to a real time synchronisation *Serial communication via Synchronisation module C (COM2) on page 82*

Connect a communication line by means of a corresponding terminal. Communication parameters are stated on the device label, regarding the selected/equipped type of communication. Connector terminals are marked on the label on a devices' rear side. More detailed information on communication is given in chapter *Communication on page 56*.

COMMUNICATION				
TERMINAL				
RS485		RS232		
A	B	Rx	↓	Tx
21	22	23	24	25

Example of a label for RS232 and RS485 communication with a pluggable screw terminal connector

COMMUNICATION	
Ethernet	
MAC No.: 00-1B-DF-54-7B-4A	
USB 2.0	Type B

Example of a label for Ethernet/USB communication module equipped with RJ-45 and USB-B type connector

COMMUNICATION	
USB 2.0	Type B

Example of a label for USB communication with USB-B type connector

RS232

RS232 communication is intended for direct connection of the Device to the personal computer. For proper operation it is necessary to assure the corresponding connection of individual terminals (see table below).

RS485

RS485 communication is intended for connection of multiple devices to a network where devices with RS485 communication are connected to a common communication interface. We suggest using one of the GOSSSEN METRAWATT communication interfaces!

For proper operation it is necessary to assure the corresponding connection of individual terminals (see table below).

Ethernet

Ethernet communication is used for connection of device to the Ethernet network for remote operation. Each device has its own MAC address that at some cases needs to be provided and is printed on the label on the device.

USB



USB communication serves as a fast peer-to-terminal data link. The device is detected by host as a USB 2.0 compatible device. The USB connection is provided through a USB standard Type B connector.



PLEASE NOTE

When device is connected to a PC through USB communication for the first time, a user is prompted to install a driver. The driver is provided on the CD, enclosed in the original shipment package, or it can be downloaded from the GOSSSEN METRAWATT web page www.gossenmetrawatt.com. With this driver installed, USB is redirected to a serial port, which should be selected when using MAVO-View setting software.

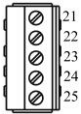
Table 2: Survey of communication connection

	Connector	Terminals	Position	Data direction	Description
RS485 RS232	Screw terminal		21	To/From	A
			22	To/From	B
			23	To	Data reception (Rx)
			24	-	Grounding (⊥)
			25	From	Data transmission (Tx)
Ethernet	RJ-45		100BASE-T CAT5 cable recommended		
USB	USB-B		Standard USB 2.0 compatible cable recommended (Type B plug)		

Connection of Real Time Synchronization module C

Synchronized real-time clock (RTC) is an essential part of any Class A analyzer for proper chronological determination of various events. To distinct cause from consequence, to follow a certain event from its origin to manifestation in other parameters it is very important that each and every event and recorded measurement on one instrument can be compared with events and measurements on other devices. Even if instruments are dislocated, which is normally the case in electro distribution network events have to be time-comparable with accuracy better than a single period.

Synchronisation module is used to synchronise RTC of the device and to maintain its accuracy for correct aggregation intervals and time stamps of recorded events appearing in monitored electro distribution network.

Different types of RTC synchronisation are possible:

- IRIG-B modulated; 1 kHz modulation with <1ms resolution.
- IRIG-B unmodulated (level shift)
- 1PPS + RS232 Date & Time telegram (from GPS)

PLEASE NOTE



NTP synchronisation is also possible via Ethernet communication if Ethernet communication module is used. See *chapter Real Time Synchronisation source on page 48 for instructions how to select NTP RTC synchronisation.*

GPS time synchronization:

1pps and serial RS232 communication with NMEA 0183 sentence support. GPS interface is designed as 5 pole pluggable terminal (+5V for receiver supply, 1pps input and standard RS232 communication interface). Proposed GPS receiver is GARMIN GPS18x

IRIG time code B (IRIG-B):

Unmodulated (DC 5V level shift) and modulated (1 kHz) serial coded format with support for 1pps, day of year, current year and straight seconds of day as described in standard IRIG-200-04. Supported serial time code formats are IRIG-B007 and IRIG-B127

Interface for modulated IRIG-B is designed as BNC-F terminal with 600 Ohm input impedence. Interface for unmodulated IRIG-B is designed as pluggable terminal (see *table 3*).

Network time protocol (NTP):

Synchronization via Ethernet requires access to a NTP server.



PLEASE NOTE

NTP can usually maintain time to within tens of milliseconds over the public Internet, but the accuracy depends on infrastructure properties - asymmetry in outgoing and incoming communication delay affects systematic bias. It is recommended that dedicated network rather than public network is used for synchronisation purposes.

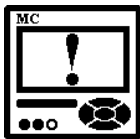

CAUTION

RTC synchronisation is essential part of Class A instrument. If no proper RTC synchronisation is provided device operates as Class S instrument.

Table 3: Survey of synchronisation connection

Terminals	Connector type
	BNC for modulated IRIG-B and Pluggable screw terminals for level-shift IRIG-B, GPS modem or serial RS232 or RS485 interfaces

Connector	Position	Data direction	Description
BNC connector	600 Ohm input impedance: standard Coaxial cable (55 Ohm) recommended		
Screw terminal	53	1PPS (GPS) or IRIG-B (level shift)	Synchronisation pulse
	54	To/From (A)	RS485
	55	To/From (B)	RS485
	56	To	Data reception (Rx)
	57	GND	Grounding
	58	From	Data transmission (Tx)
	59	+5V	AUX voltage +5V (supply for GPS modem)

When IRIG-B or 1PPS signal is used for time synchronisation serial communication interface (RS232 or RS485) can be used as a devices' secondary communication port (COM2).

More information regarding use of Synchronisation module C is in chapter *Synchronisation module C on page 81* and *Serial communication via Synchronisation module C (COM2) on page 82*.

Connection of aux. power supply

Device can be equipped with either of two types of universal (AC/DC) switching power supply.

Feature A00 (Standard): 70...300 V DC

80...276 V AC; 40...65 Hz

Feature A01 (no longer available): 19...70 V DC

48...77 V AC; 40...65 Hz

Power supply voltage depends on ordered voltage. Information on electric consumption is given in chapter *Technical data on page 145*.

Regarding power supply voltage specification on the label, choose and connect the power supply voltage:

SUPPLY		
70...300 V DC	⏚	12
80...276 V AC	+~L	13
40...65 Hz	-~N	14
< 8 VA		

Feature A00: Connection of universal power supply type High to terminals 13 and 14.

SUPPLY		
19...70 V DC	⏚	12
48...77 V AC	+~L	13
40...65 Hz	-~N	14
< 8 VA		

Feature A01: Connection of universal power supply type Low to terminals 13 and 14.

WARNING!

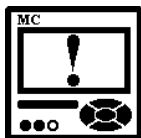

Feature A01 only:

Auxiliary power supply can be LOW range (19-70V_{DC}, 48-77V_{AC}).

Connecting device with LOW power supply to higher voltage will cause device malfunction. Check device specification before turning it on!

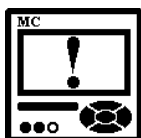

CAUTION



Aux. supply inrush current can be as high as 20A for short period of time (<1 ms). Please choose an appropriate MCB for connection of aux. supply.

FIRST STEPS

Programming **MAVOLOG PRO Quality Analyser** is very transparent and user friendly. Numerous settings are organized in groups according to their functionality.

Programming **MAVOLOG PRO Quality Analyser** can be performed using the keypad and display on the front panel. Due to representation of certain settings not all settings can be programmed this way. All settings can be programmed using MAVO-View software.

Information about which settings are available with keypad and which are available using communication and MAVO-View software is given next to each setting's name in a graphical form:

-  – Function accessible using communication (MAVO-View software)
-   – Function accessible using keypad and the display





In this chapter you will find basic programming steps which can be accessed by using keypad and display:

BASIC CONCEPTS	33
INSTALLATION WIZARD	33
DISPLAY OF DEVICE INFO	36

Basic concepts

Navigation keypad and LCD enable basic device settings. During the operation some icons can be displayed in upper part of LCD. The significance of icons (from right to left) is explained in the table below.

Table 4: Survey of notification icons

Icon	Meaning
	Device is locked with a password of the second level (L2). The first level (L1) can be unlocked.
	Device has been wrongly connected at voltage measuring input/current input. Energy flow direction differs, depending on the respective phase.
	The aux. power supply of the device supply is too low.
	Clock not set. (if disconnected from aux. supply for more than 2 days)

The meaning of icons is also explained on a LCD in the Information menu. See chapter *Display of device info* on page 36.

Installation wizard

After installation and electrical connection, basic parameters have to be set in order to assure correct operation. The easiest way to achieve that is to use the Installation wizard.

Main menu	
Measurements	
Settings	
Resets	
SD card	
Info	
Installation	
14.11.2012	16:53:36

When entering the Installation menu (use navigation keys as shown in picture above and press OK button), settings follow one another when the previous one is confirmed. All required parameters shall be entered and confirmed. Exit from the menu is possible when all required settings are confirmed or with interruption (key \leftarrow several times) without changes.

Installation wizard menu may vary, depending on built in communication modules. In description below is marked which menu appears for specific option.

PLEASE NOTE



All settings that are performed through the Installation wizard can be subsequently changed by means of the Settings menu or via MAVO-View by means of communication or a Memory card.

When entering installation wizard following display is shown:

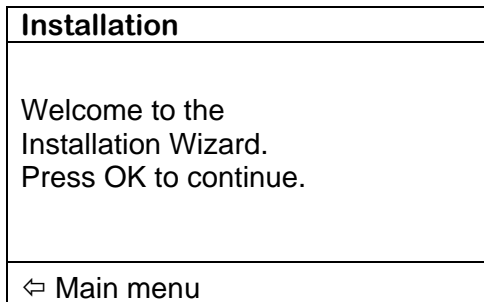

Language

Set device language.

Date

Set device date.

Time

Set device time. If instrument is connected to one of supported time synchronisation sources, date and time are automatically set.

Connection mode

Choose connection from a list of supported connection modes.

Primary voltage

Set primary voltage of monitored system if a device is connected indirectly by means of a voltage transformer. If device is directly connected to a low-voltage source, enter this value.

Secondary voltage

Set secondary voltage if a voltage transformer is used; set voltage of low voltage network if connection is direct.

Primary current

Set primary current of monitored system if a device is connected indirectly by means of a current transformer. Otherwise primary and secondary current should remain the same.

Secondary current

Set secondary current of current transformer or the value of nominal current if connection is direct.

Common energy counter resolution

Define Common energy counter resolution as recommended in table below, where Individual counter resolution is at default value 10. Values of primary voltage and current determine proper Common energy counter resolution. For detailed information about setting energy parameters see chapter *Energy on page 67*.

Table 5: Suggested Common energy counter resolutions

Current Voltage	1 A	5 A	50 A	100 A	1000 A
110 V	100 mWh	1 Wh	10 Wh	10 Wh	100 Wh
230 V	1 Wh	1 Wh	10 Wh	100 Wh	1 kWh
1000 V	1 Wh	10 Wh	100 Wh	1 kWh	10 kWh
30 kV	100 Wh	100 Wh	1 kWh	10 kWh	10 kWh *

* – Individual counter resolution should be at least 100

Device address

Set MODBUS address for the device. Default address is 33.

Baud rate

Set communication rate. Default rate is 115200 b/s. This setting is available only when RS232 / RS485 communication is built in.

Parity

Set communication parity. Default value is "None". This setting is available only when RS232 / RS485 communication is built in.

Stop bit

Set communication stop bits. Default value is 2. This setting is available only when RS232 / RS485 communication is built in.

IP Address

Set correct IP address of the device. Default setting is 0.0.0.0 and represents DHCP addressing. This setting is available only when Ethernet communication is built in.

TCP Port

Set TCP communication Port. Default value is 10001. This setting is available only when Ethernet communication is built in.

Subnet mask

Set network subnet mask. Default value is 255.255.255.0. This setting is available only when Ethernet communication is built in.

Display of device info

A menu is divided into several submenus with data and information about device:

Welcome screen

Information

Serial number, Hardware and Firmware version, date of calibration and operational time

Memory

Internal memory storage availability. Memory information shows available memory since last official data transfer. If official data transfer is performed, device will virtually erase entire memory. It will set memory counters to zero but it will not overwrite existing data. This data is available until memory space overflows and starts overwriting previous data.

Time, date, internal temperature and tariff status

Meaning of icons

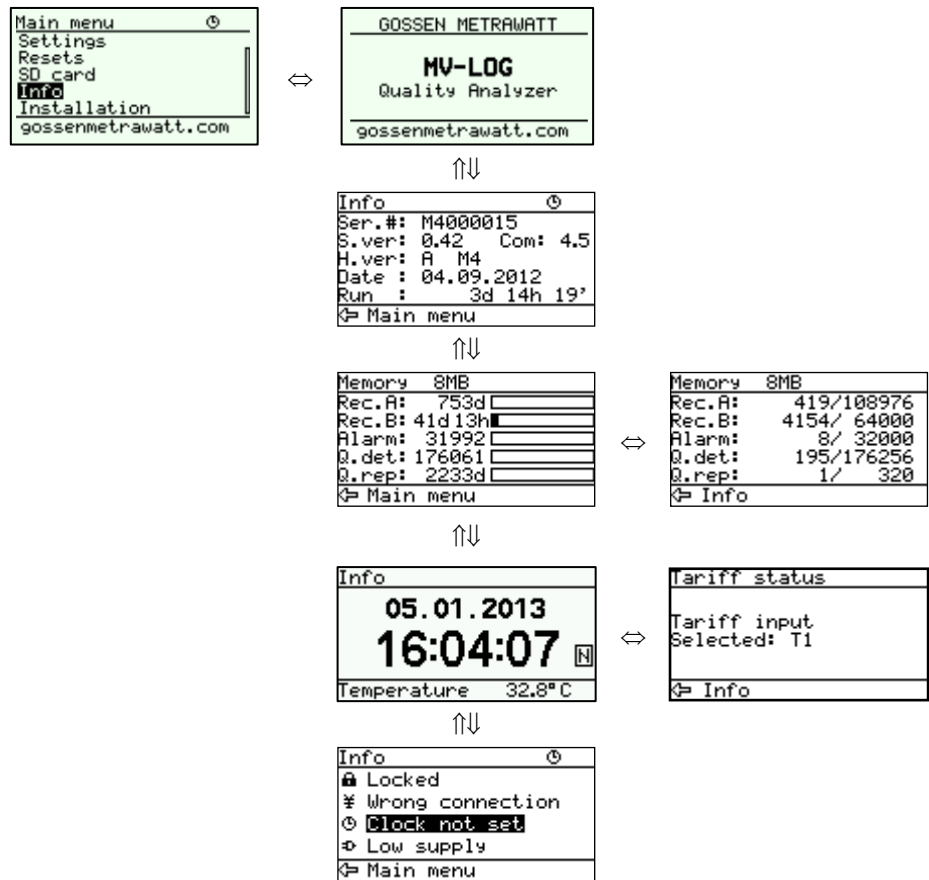

SETTINGS

A setting structure, which is similar to a file structure in an explorer is displayed in the left part of the MAVO-View setting window. Available settings of that segment are displayed in the right part by clicking any of the stated parameters.

In this chapter you will find detailed description of all **MAVOLOG PRO** features and settings. Chapter is organized in a way to follow settings organisation as in setting software MAVO-View.

INTRODUCTION	38
MAVO-VIEW SOFTWARE	38
DEVICES MANAGEMENT	39
DEVICE SETTINGS	41
REAL-TIME MEASUREMENTS	43
DATA ANALYSIS	44
SOFTWARE UPGRADING	45
GENERAL SETTINGS	46
CONNECTION	54
SERIAL COMMUNICATION	56
USB COMMUNICATION	58
ETHERNET COMMUNICATION	59
DISPLAY	63
SECURITY	65
ENERGY	67
I/O MODULES	72
MAIN I/O MODULES 1 & 2	72
AUXILIARY I/O MODULES A & B	80
RTC SYNCHRONIZATION MODULE C ^{PC}	81
ALARMS	83
ALARMS PUSH FUNCTIONALITY ^{PC}	83
INTERNAL MEMORY	88
CONFORMITY OF VOLTAGE WITH EN 50160 STANDARD	93
GENERAL PQ SETTINGS	94
EN 50160 PARAMETERS SETTINGS	97
RESET OPERATIONS	99
SETTINGS AND MEMORY CARD	101

Introduction

Settings of **MAVOLOG PRO Quality Analyser** can be performed via the front keypad and display or remotely using communication and MAVO-View software version 2.0 or higher. Setting is faster and easier by using MAVO-View. Basic and simpler settings are accessible via navigation keypad. For new setting to be activated settings file should be transferred to the device via communication (MAVO-View) or a memory card. Setting via navigation keypad comes into function after confirmation (OK button), followed by an extended acoustic signal (beep).

MAVO-View software

MAVO-View software is a tool for a complete programming and monitoring of GOSSEN METRAWATT measuring instruments. Remote operation is possible by means of serial (RS485/RS232), USB or TCP/IP communication in connection with a PC. A user-friendly interface consists of five segments: devices management, device settings, real-time measurements, data analysis and software upgrading. These segments are easily accessed by means of five icons on the left side (see Figure 2).

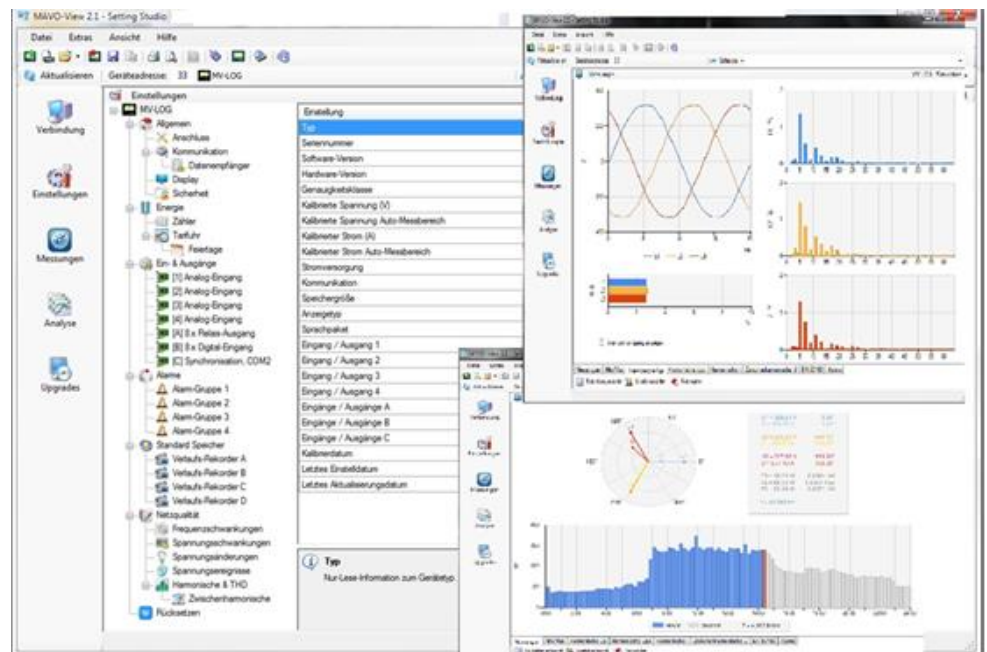

Figure 2: MAVO-View programming and monitoring software

MAVO-View version 2.0 or higher is required for programming and monitoring **MAVOLOG PRO** Quality Analyser. Software installation is stored on a CD as a part of consignment or it can be downloaded from www.gossenmetrawatt.com.



PLEASE NOTE

MAVO-View has very intuitive help system. All functions and settings are described in *Info* window on the bottom of MAVO-View window.

Devices management

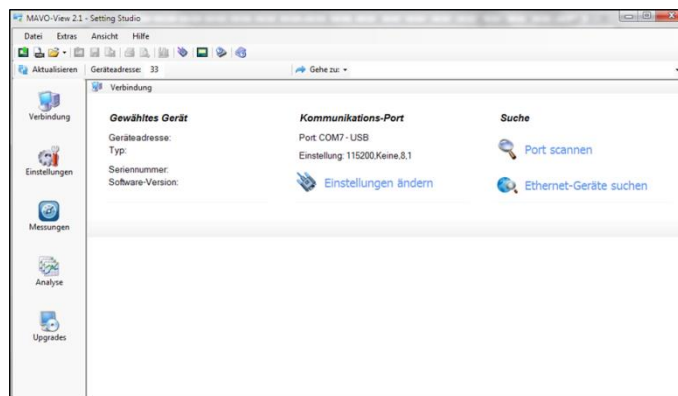
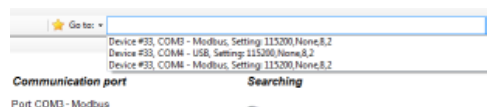

Figure 3: MAVO-View Device Management window

With MAVO-View it is very easy to manage devices. If dealing with the same device that has been accessed before it can be easily selected from a favourite's line.



This way *Communication port* is set automatically as it was during last access.

To communicate with new device, the following steps should be followed:

Connect a device to a communication interface

Depending on type of communication interface connect a device:

- Directly to a PC using RS232 cable
- To comm. adapter RS485 / RS232
- Directly to a PC using USB cable
- Network connection using Ethernet cable

Set Communication port parameters

Under *Communication port* current communication parameters are displayed. To change those parameters click on  *Change settings* button. A Communication port window opens with different communication interfaces.

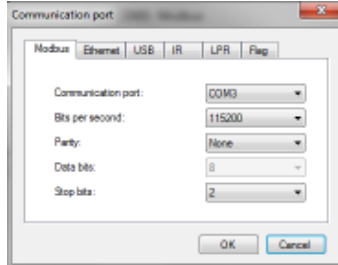

Choose correct communication interface (Modbus, Ethernet or USB) and set correct communication parameters.

PLEASE NOTE



When device is connected to a PC through USB communication for the first time, the user is prompted to install a driver. The driver is provided on the CD, enclosed in the original shipment package, or it can be downloaded from the GOSSEN METRAWATT web page www.gossenmetrawatt.com. With this driver installed, USB is redirected to a serial port, which should be selected when using MAVO-View setting software.

For more information regarding parameters for serial, USB and Ethernet communication see chapters Serial Communication on page 56, USB communication on page 58 and Ethernet communication on page 59.

Set device Modbus address number

Each device connected to a network has its unique Modbus address number. In order to communicate with that device an appropriate address number should be set.

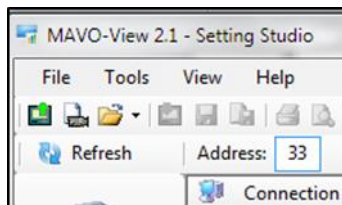

Factory default Modbus address for all devices is 33. Therefore it is required to change Modbus address number of devices if they are connected in the network so each device will have its unique address number.

Start communicating with a device

Click on REFRESH button and devices information will be displayed

Communication	
Address	33
Bits/s	115200
Parity	None
Stop bits	1
General	
Type	MV-LOG
Ser. No.	MC018923
Soft. Ver.	1.01

When devices are connected to a network and a certain device is required it is possible to browse a network for devices. For this purpose choose

Scan the network when device is connected to a RS485 bus

Browse ethernet devices when device is connected to the Ethernet

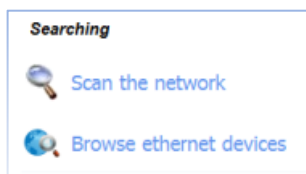

Device settings

Programming devices can be performed ONLINE when device is connected to aux. power supply and is communicating with MAVO-View. When device is not connected it is possible to adjust settings OFFLINE.

ONLINE programming

After communication with a device is established, choose icon *Settings* from a list of MAVO-View functions on a left side.

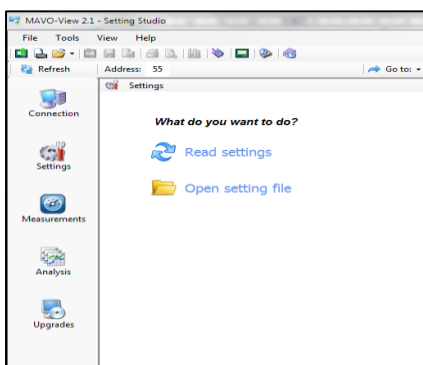



Figure 4: MAVO-View Device Setting window

Choose *Read settings* button to display all devices settings and begin adjusting them according to project requirement.



PLEASE NOTE

When finished programming, changes should be confirmed by pressing *Download settings* button in MAVO-View menu bar () or with a mouse right click menu.



PLEASE NOTE

When finished programming, all settings can be saved in a setting file (*.msf file). This way it is possible to archive settings in combination with a date. It is also possible to use saved settings for offline programming or to program other devices with same settings. For more information see OFFLINE programming.

OFFLINE programming

When device is not physically present or is unable to communicate it is still possible to perform OFFLINE programming. From MAVO-View Device Setting window (Figure 4) choose *Open setting file* button.

From a list of *.msf files choose either previously stored file (a setting file, which has been used for another **MAVOLOG PRO** and stored) or a file **MAVOLOG PRO**.msf, which holds default settings for this device.

When confirmed all device settings are displayed similar as with ONLINE programming.

CAUTION

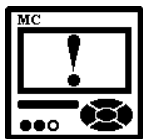

MAVOLOG PRO.msf file or any other original device setting file should not be modified as it contains device default settings. Before adjusting settings according to project requirements save setting file under another name.

When finished programming, all settings can be saved in a setting file with a meaningful name (e.g. **MAVOLOG PRO_location_date**.msf). This file can then be transferred to a memory card and used for programming on listed devices, which are not accessible via communication.

Real-time measurements

Measurements can be seen ONLINE when device is connected to aux. power supply and is communicating with MAVO-View. When device is not connected it is possible to see OFFLINE measurements simulation. The latter is useful for presentations and visualisation of measurements without presence of actual device.

In ONLINE mode all supported measurements and alarms can be seen in real time in tabular or graphical form.

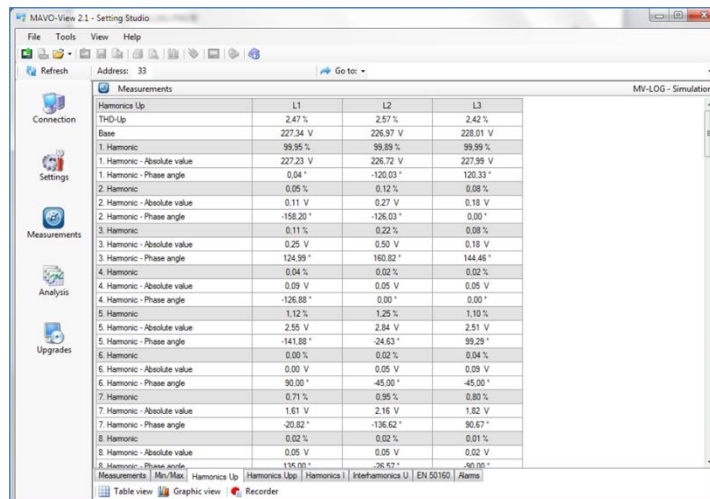

Figure 5: Online measurements in tabular form

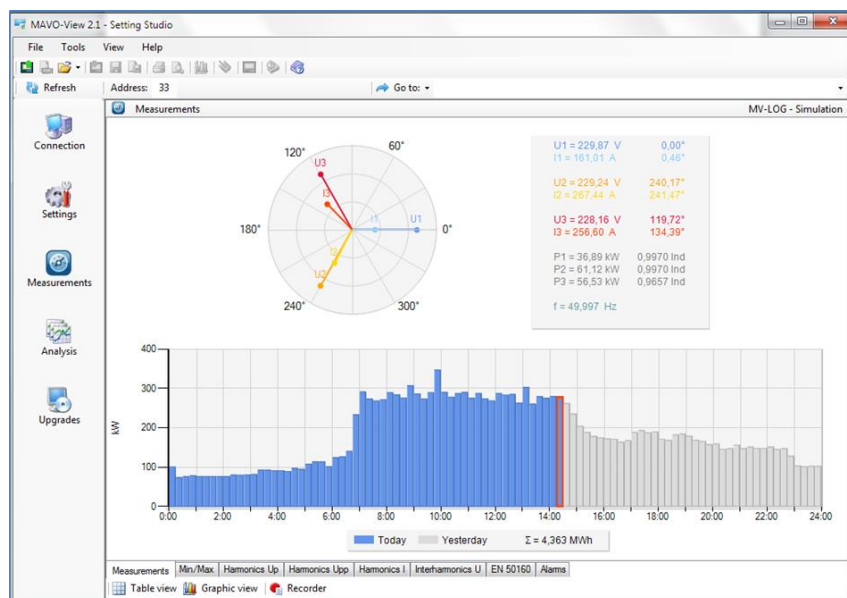



Figure 6: Online measurements in graphical form – phaser diagram and daily total active power consumption histogram

Different measuring data can be accessed by means of tabs (Measurements, Min/Max...) in the lower part of MAVO-View window.

For further processing of the results of measurements, it is possible to set a recorder ( Recorder button) on active device that will record and save selected measurements to MS Excel .csv file format.

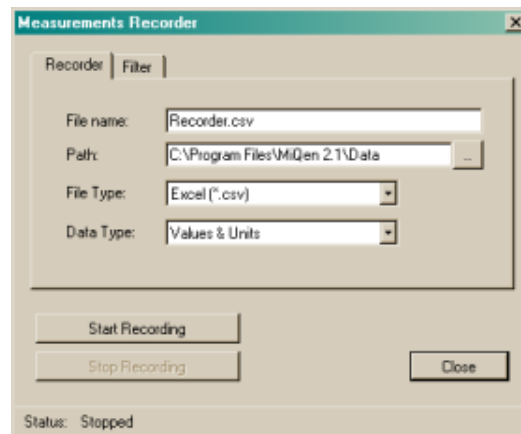
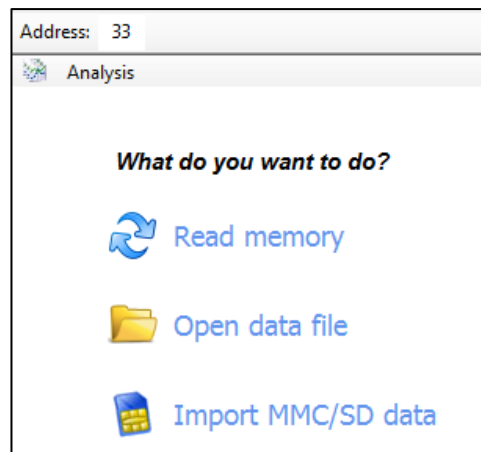

Figure 7: Window for setting local database recording parameters

Data analysis

In order to perform analysis, the data source has to be defined first. Data source can be one of the selected:



Read memory

Data is read directly from a device internal memory

Open data file

Data is read from a local database

Import SD data

Data is imported from a SD memory card

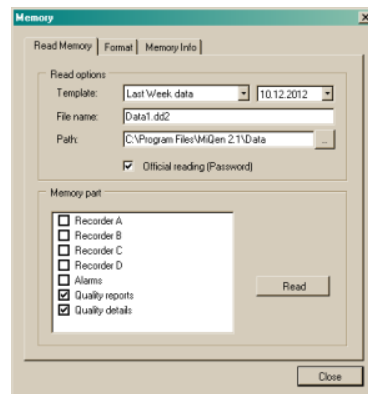

Figure 8: Window for a choice of memory data to be analysed

After data is read or imported recorded quantities can be monitored in a tabular or a graphical form. The events that triggered alarms can be analyzed or a report on supply voltage quality can be made. All data can be exported to an Access data base, Excel worksheets or as a text file.

Reading and deletion of memory data (Parameter Official Reading):

When this function has been selected, the marker is moved to the selected period of time. The measured values are read from the internal device memory and are subsequently cleared from memory up to the marker position.

Example:

The memory contains the measurement data from a period of twelve weeks. All data are to be read out. The marker is placed on the up-to-date data record (e.g. today, 12.30 a.m.). The measured values are loaded from the internal memory into the software, at the same time being cleared from the internal memory.



Software upgrading

Always use the latest version of software, both MAVO-View and software in the device. The program automatically informs you about available upgrades (device firmware upgrades and MAVO-View software upgrades) that can be transferred from the web site and used for upgrading.

PLEASE NOTE

MAVO-View cannot be used for execution of firmware upgrades of devices. It only informs that new version is available and offers link to download it from the server. Software for execution of firmware upgrades is included in downloaded zip file together with upgrade file, upgrade procedure description and revision history.

General settings

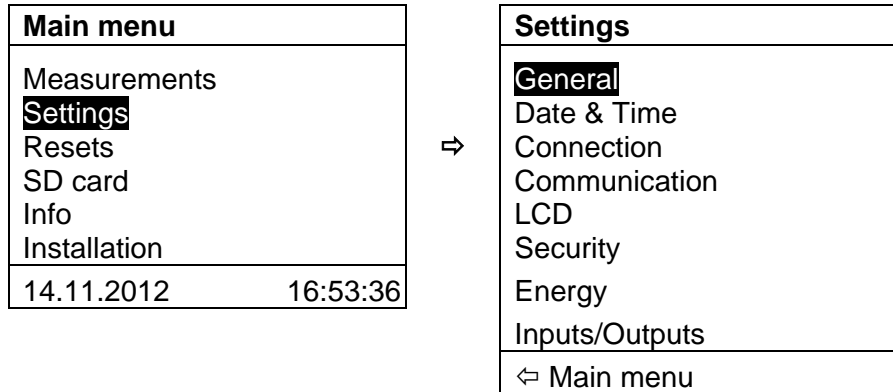

General settings are essential for Quality Analyser. They are divided into four additional sublevels (Connection, Communication, Display and Security).

Description and Location PC

These two parameters are intended for easier recognition of a certain unit. They are especially used for identification of the device or location on which measurements are performed.

Average interval PC

The averaging interval defines a refresh rate of measurements on display, communication and analogue outputs. It also defines response time for alarms set to Normal response (see chapter *Alarms on page 83*). Interval can be set from 0.1 to 5 s. Default value is 1 s.

Main menu ⇒ **Settings** ⇒ **General** ⇒ **Average interval**

Average interval for Min/Max values PC

The averaging interval for Min/Max values defines an interval on which values will be averaged to track Min and Max values. By choosing shorter interval also very fast changes in the network will be detected. Interval can be set form 1 to 256 periods.



PLEASE NOTE

This setting applies only for min. and max. values displayed on LCD and accessible on communication. These values are not used for storing into internal recorder. For more information about recording min. and max. values see *Min and Max values on page 122*.

Language  

Set language for display. When language is changed from or to Russian, characters of the password are changed too. For overview of character translation see chapter *Password and language on page 66*.

 **Main menu** ⇒ **Settings** ⇒ **General** ⇒ **Language**

Currency  

Choose currency for evaluating energy cost (see chapter *Energy on page 67*). A currency designation consists of up to four letters taken from the English or Russian alphabet and numbers and symbols stated in table below.

English	A	B	C	D	E	F	G	H	I	J	K	L	M	N	O	P	Q	R	S	T	U	V	W	X	Y	Z
	a	b	c	d	e	f	g	h	i	j	k	l	m	n	o	p	q	r	s	t	u	v	w	x	y	z
Symbols	!	"	#	\$	%	&	'	()	*	+	,	-	.	/	0 to 9	:	;	<	=	>	?	@			
Russian	А	Б	В	Г	Д	Е	Ж	З	И	Й	К	Л	М	Н	О	П	Р	С	Т	У	Ф	Х	Ц	Ч	Ш	Щ
	а	б	в	г	д	е	ж	з	и	й	к	л	м	н	о	п	р	с	т	у	ф	х	ц	ч	ш	щ

 **Main menu** ⇒ **Settings** ⇒ **General** ⇒ **Currency**

Temperature unit  

Choose a unit for temperature display. Degrees Celsius or degrees Fahrenheit are available.

 **Main menu** ⇒ **Settings** ⇒ **General** ⇒ **Temperature unit**

Date format  

Set a date format for time stamped values.

 **Main menu** ⇒ **Settings** ⇒ **Date & Time** ⇒ **Date format**

Date and time  

Set date and time of the device. Setting is important for correct memory operation, maximal values (MD), etc. If instrument is connected to one of supported time synchronisation sources, date and time are automatically set.

 **Main menu** ⇒ **Settings** ⇒ **Date & Time**

Real Time synchronisation source PC

Synchronized real-time clock (RTC) is an essential part of any Class A analyzer for proper chronological determination of various events. To distinct cause from consequence, to follow a certain event from its origin to manifestation in other parameters it is very important that each and every event and recorded measurement on one device can be compared with events and measurements on other devices. Even if devices are dislocated, which is normally the case in electro distribution network events have to be time-comparable with accuracy better than a single period.

For this purpose devices normally support highly accurate internal RTC. Still this is not enough, since temperature is location dependant and it influences its precision. For that reason it is required to implement periodical RTC synchronization.

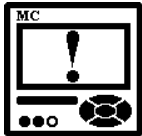

CAUTION

RTC synchronisation is essential part of Class A instrument. If no proper RTC synchronisation is provided device operates as Class S instrument.

This setting is used to choose primary synchronisation source.

- NO synchronisation (not advisable, see CAUTION above)
- NTP synchronisation
- MODULE C synchronisation

Synchronisation status can be checked on display when set to INFO display (see chapter *Display of device info* on page 36).

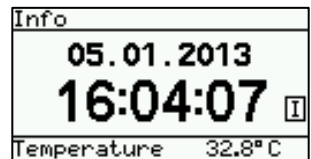

Notification icon N shows successful NTP synchronisation

Notification icon G shows successful GPS synchronisation. If only 1pps signal is present (without date and time feed) notification icon g is present

Notification icon I shows successful IRIG synchronisation

Time zone 

Set time zone in which device is mounted. Time zone influences internal time and time stamps. When UTC time is required, time zone 0 (GMT) should be chosen.

Automatic conversion to daylight saving time (summer) / regular time (winter)  

If Yes is chosen, time will be automatically shifted to regular or daylight saving time, depending on the time that is momentarily set.

Maximum demand calculation (MD mode)  

The device provides maximum demand values from a variety of average demand values:

Thermal function

Fixed window

Sliding windows (up to 15)

Thermal function

A thermal function assures exponent thermal characteristic based on simulation of bimetal meters.

Maximal values and time of their occurrence are stored in device. A time constant can be set from 1 to 255 minutes and is 6 times thermal time constant ($t. c. = 6 \times \text{thermal time constant}$).

Example:

Mode:	Thermal function
Time constant:	8 min.
Running MD and maximal MD:	Reset at 0 min.

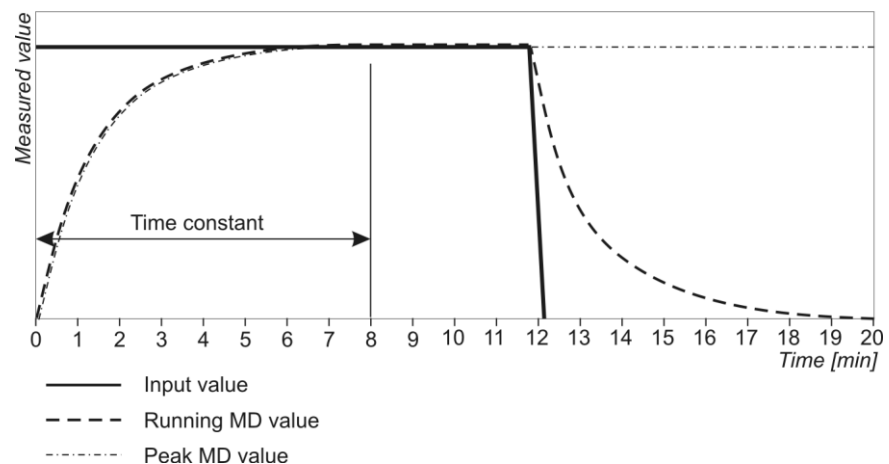

Figure 9: Operation of thermal MD function

Fixed window

A fixed window is a mode that calculates average value over a fixed time period. Time constant can be set from 1 to 255 min.

»Time into period« as displayed in MAVO-View actively shows the remaining time until the end of the period in which current MD and maximal MD from the last reset are calculated.

When displays for Pt(+/-), Qt (L/C), St, I1, I2 and I3 are updated, a new period and measurement of new average values are started. »TIME INTO PERIOD« then shows 0 of X min where X is Time Constant.

A new period also starts after a longer interruption of power supply (more than 1 s). If time constant is set to one of the values of 2, 3, 4, 5, 6, 10, 12, 15, 20, 30 or 60 minutes, »TIME INTO PERIOD« is set to such value that one of the following intervals will be terminated at a full hour. In other cases of time constants, »TIME INTO PERIOD« is set to 0.

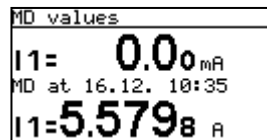

Figure above shows display of MD measurement for current I1. Running MD is displayed (0 mA), max. value of MD since last reset is displayed and its time of occurrence.

Example:

Mode: Fixed window
 Time constant: 8 min.
 Running MD and maximal MD: Reset at 0 min.

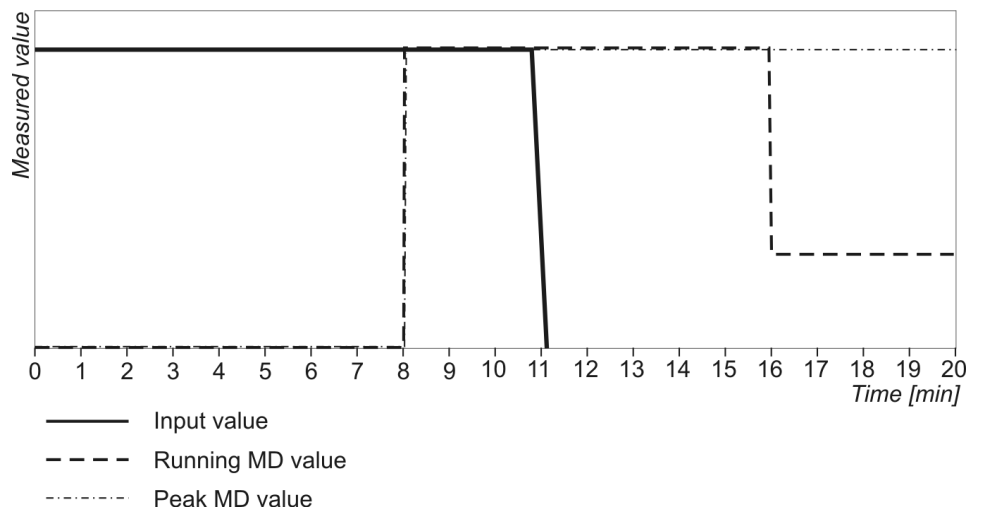

Figure 10: Operation of Fixed window MD function

Sliding windows

A mode of sliding windows enables multiple calculations of average in a period and thus more frequent refreshing of measuring results. Average value over a complete period is displayed. A running MD is updated every sub-period for average of previous sub-periods.

A number of sub-periods can be set from 2 to 15.

A time constant can be set from 1 to 255 minutes.

A new period also starts after a longer interruption of power supply (more than 1 s). If time constant is set to one of the values of 2, 3, 4, 5, 6, 10, 12, 15, 20, 30 or 60 minutes, »TIME INTO PERIOD« is set to such value that one of the following intervals will be terminated at a full hour. In other cases of time constants, »TIME INTO PERIOD« is set to 0.

Example:

Mode:	Sliding windows
Time constant:	2 min.
No. of sub-periods:	4
Running MD and maximal MD:	Reset at 0 min.

A complete period lasts for 8 minutes and consists of 4 sub-periods that are 2 minutes long. A running MD and a maximal MD are reset at 0 min. "Time into period" is data for a sub period so that the values for a running MD and a maximal MD are refreshed every two minutes. After 4 sub-periods (1 complete period) the oldest sub period is eliminated when a new one is added, so that average (a window) always covers the last 4 sub-periods.

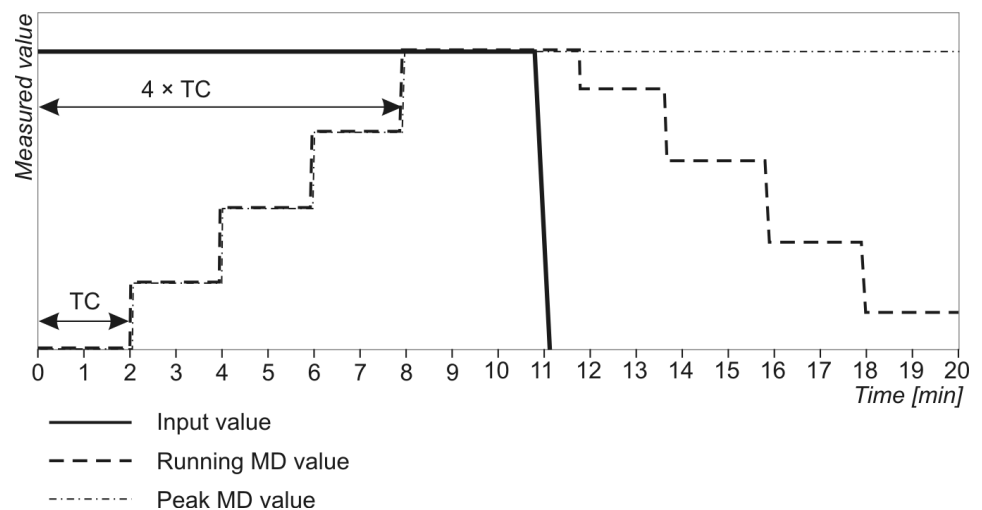

Figure 11: Operation of Sliding window MD function

🔍 Main menu ⇒ Settings ⇒ General ⇒ MD mode / MD time const.

Min/Max reset mode

This setting defines a mode of resetting stored Min/Max values. It can be set to

- manual** (see chapter *Reset on page 99*) or
- automatic** (daily, weekly, monthly or yearly reset).

Automatic resets are performed at every beginning of defined period at midnight.

Daily	every day at 00:00,
Weekly	on Monday at 00:00,
Monthly	the first day in a month at 00:00,
Yearly	the first day in a year 1.1. at 00:00

 **Main menu** ⇒ **Settings** ⇒ **General** ⇒ **Min/Max reset mode**

Starting current for PF and PA (mA)

All measuring inputs are influenced by noise of various frequencies. It is more or less constant and its influence to the accuracy is increased by decreasing measuring signals. It is present also when measuring signals are not present or are very low. It causes very sporadic measurements.

This setting defines the lowest current that allows regular calculation of Power Factor (PF) and Power Angle (PA).

The value for starting current should be set according to conditions in a system (level of noise, random current fluctuation...)

Starting current for all powers (mA)

Noise is limited with a starting current also at measurements and calculations of powers.

The value for starting current should be set according to conditions in a system (level of noise, random current fluctuation...)

Starting voltage for SYNC (V)

Device needs to synchronize its sampling with measuring signals period to accurately determine its frequency. For that purpose, input signal has to large enough to be distinguished from a noise.

If all phase voltages are smaller than this (noise limit) setting, instrument uses current inputs for synchronization. If also all phase currents are smaller than *Starting current for PF and PA* setting, synchronization is not possible and frequency displayed is 0.

The value for starting voltage should be set according to conditions in a system (level of noise, random voltage fluctuation...)

Harmonics calculation PC

Relative harmonic values can be different according to used base unit. According to requirements relative harmonics can be calculated as:

percentage of RMS signal value (current, voltage) or
percentage of the fundamental (first harmonic).

Reactive power and energy calculation PC

Harmonic distortion can significantly influence reactive power and energy calculation. In absence of harmonic distortion both described methods will offer the same result. In reality harmonics are always present. Therefore it is up to project requirements, which method is applicable.

User can select between two different principles of reactive power and energy calculation:

Standard method:

With this method a reactive power and energy are calculated based on assumption that all power (energy), which is not active, is reactive.

$$Q_2 = S_2 - P_2$$

This means also that all higher harmonics (out of phase with base harmonic) will be measured as reactive power (energy).

Delayed current method:

With this method, reactive power (energy) is calculated by multiplication of voltage samples and delayed current samples (see chapter *Equations on page 176*):

$$Q = U \times I|_{+90^\circ}$$

With this method, reactive power (energy) represents only true reactive component of apparent power (energy).

Connection

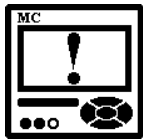
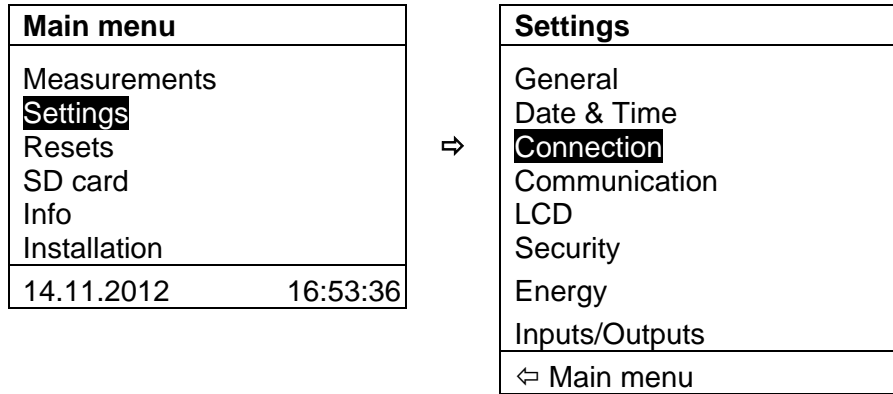

CAUTION

Settings of connections shall reflect actual state otherwise measurements could not be valid.

Connection mode

When connection is selected, load connection and the supported measurements are defined (see chapter *Selection of available quantities on page 109*).

Main menu ⇒ **Settings** ⇒ **Connection** ⇒ **Connection mode**

Setting of current and voltage ratios

Before setting current and voltage ratios it is necessary to be familiar with the conditions in which device will be used. All other measurements and calculations depend on these settings. Up to five decimal places can be set. To set decimal point and prefix position the cursor to last (empty) place or the decimal point.

Aux CT transformer ratios can be set separately from phase CT ratios since Aux CT could differ from phase CTs.

Table 6: Range of CT and VT ratios

Settings range	VT primary	VT secondary	CT, Aux CT primary	CT, Aux CT secondary
Max value	1638,3 kV	13383 V	1638,3 kA	13383 A
Min value	0,1 V	1 mV	0,1 A	1 mA

Main menu ⇒ **Settings** ⇒ **Connection** ⇒ **VT/CT/Aux CT**

Used voltage and current range 

Setting of used voltage and current range is connected with all settings of alarms, analogue outputs and measurements recording.

CAUTION

In case of subsequent change of those ranges shall be alarm and analogue output settings correspondingly changed as well.

Already recorded values will not be valid after change of used voltage and current range!

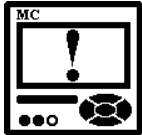
**Nominal frequency** 

Nominal frequency range can be selected from a set of predefined values. A valid frequency measurement is within the range of nominal frequency ± 30 Hz.

This setting is used for alarms and recorders only.

Wrong connection warning 

If all phase currents (active powers) do not have same sign (some are positive and some negative) and/or if phase voltages and phase currents are mixed, the warning will be activated if this setting is set to YES.

See *Survey of notification icons table on page 33*

Energy flow direction 

This setting allows manual change of energy flow direction (IMPORT to EXPORT or vice versa) in readings tab.

It has no influence on readings sent to communication or to memory!

CT connection 

If this setting is set to REVERSED it has the same influence as if CT's would be reversely connected. All power readings will also change its sign.

This setting is useful to correct wrong CT connections.

Serial communication

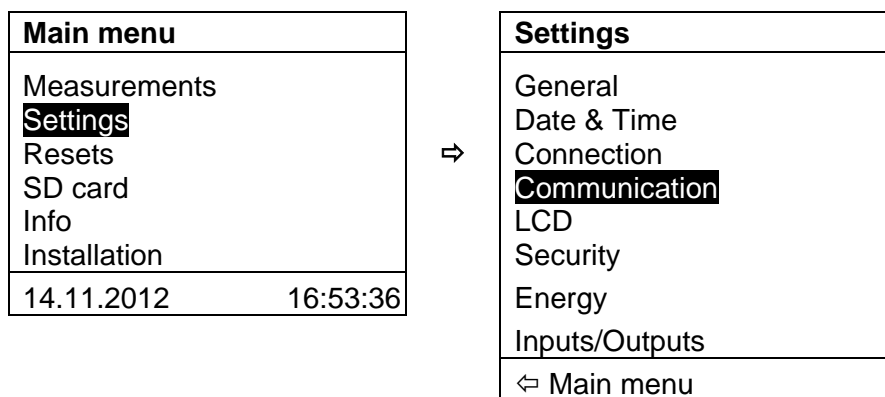

Serial Communication

Communication parameters (only for main communication port COM1), which are important for the operation in RS485 network or connections with PC via RS232 communication.

Factory settings for serial communication are

MODBUS Address	#33	address range is 1 to 247
Comm. speed	115200	speed range is 2400 to 115200
Parity	none	
data bits	8	
stop bits	2	



PLEASE NOTE

Additional settings referring to secondary communication port COM2 via synchronisation module C (in MAVO-View software) can be found in chapter *RTC Synchronisation Module C, COM2* on page 82.

 **Main menu** ⇒ **Settings** ⇒ **Communication** ⇒

Push Data Format PC

With this setting a required data format for sending data to receiver using PUSH communication mode is set. Currently supported format is XML-smart. For more information about PUSH communication mode and XML data format see *chapter Communication modes on page 140* and *appendix D on page 180*.

Push Response time PC

With this setting a maximum waiting time for acknowledgement of sent data in PUSH communication mode is set. If acknowledgement from a client is not sent within this time, scheduled data will be resend in next push period.

Push Time synchronisation PC

In case where no other synchronisation source is available (GPS, IRIG-B, NTP), RTC can be synchronised by push data client. This type of synchronisation strongly depends on communication infrastructure and it is not as accurate as required by IEC 61000-4-30. It has the lowest priority and cannot override RTC synchronised by any of other sources.

USB communication

USB Communication

There is no special setting for USB communication. For more detailed information how to handle device with USB communication use Help section in MAVO-View software.



PLEASE NOTE

Device supports only a single communication input (USB or Ethernet) at a time when using primary communication port COM1. Priority has USB communication. If communication using ethernet is in progress, do not connect to USB since it will terminate ethernet connection. When USB cable is unplugged from the device ethernet communication is again available.



PLEASE NOTE

When device is connected to a PC through USB communication for the first time, a user is prompted to install a driver. The driver is provided on the CD, enclosed in the original shipment package, or it can be downloaded from the GOSSEN METRAWATT. web page www.gossenmetrawatt.com. With this driver installed, USB is redirected to a serial port, which should be selected when using MAVO-View setting software.

Ethernet communication

 **Main menu** ⇒ **Settings** ⇒ **Communication** ⇒ (all settings are not supported on keypad)

Device Address

Device Modbus address is important when user is trying to connect to device via MAVO-View software. Usable range of addresses is from 1 to 247. Default address number is 33.

IP address

Communication interface should have a unique IP address in the Ethernet network. Two modes for assigning IP are possible:

Fixed IP address:

In most installations a fixed IP address is required. A system provider usually defines IP addresses. An IP address should be within a valid IP range, unique for your network and in the same subnetwork as your PC.

DHCP:

Automatic (dynamic) method of assigning IP addressed (DHCP) is used in most networks. If you are not sure if DHCP is used in your network, check it at your system provider.

IP Hostname

It is the nickname that is given to a device. The setting is used in automatic (DHCP) mode only.

Local Port

When using Ethernet communication device has opened two local ports.

- Fixed port number 502, which is a standard MODBUS port. Device allows multiple connections to this port.
- User defined port. Any port number is allowed except reserved ports (*Table 7*). Only a single connection is allowed to this port. When this port is used all other connections (including connection to port 502) are disabled. This is a terminal type of connection.

Terminal type of connection is used when due to a performed function other connections are not allowed. This is the case when firmware update is performed. In other cases it is advised to use port 502.

When port 502 is used a remote application(s) can access device regardless the setting for *Local Port* in a device. This setting is applicable only when terminal access is required.

Table 7: Reserved TCP Port numbers

Important port numbers	Function
1 – 1024, 9999, 30718, 33333	Reserved numbers!!!
502	Standard MODBUS port – fixed
33333	UDP port used for Device Discovery Service

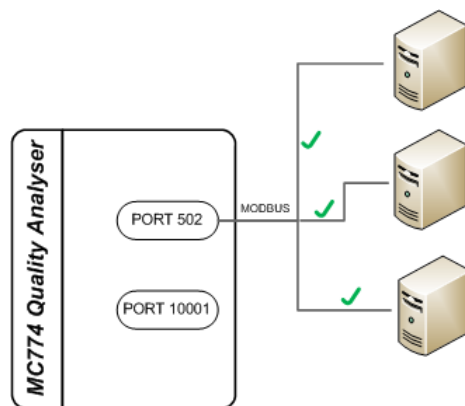

Figure 12: Multiple connections to a device are possible when port 502 (special MODBUS port) is used

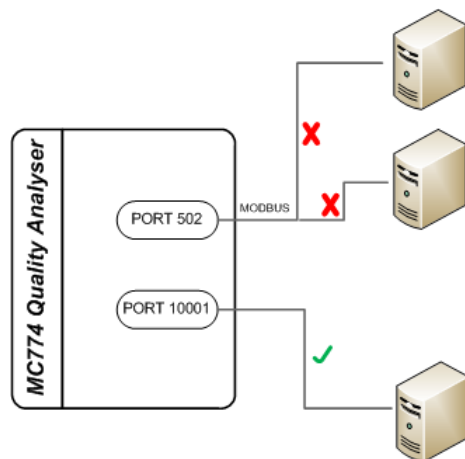

Figure 13: When any other allowed port is used only a single connection is possible

Port 502

Is standardized port to communicate with the device via MODBUS/TCP communication protocol and is fixed.

Communication via this port allows multiple connections to the device. Communication over this port does not block any other traffic.

Port 33333

This UDP port is reserved for Discovery Service, a service run by MAVO-View software, to discover devices connected in to local Ethernet communication network.

Other available Ports

Other, allowed TCP ports, are acting as terminal port and when connected to it, it blocks all other connections until it is released. Priority, when connected to this port, has PUSH functionality of the device.

Subnet Mask  

It is used to determine what subnet an IP address belongs to.

Gateway Address 

It is a gateway that connects separate network segments (LAN, WAN or internet).

NTP Server 

IP address of a NTP server used for time synchronisation of the device.

NTP can usually maintain time to within tens of milliseconds over the public Internet, but the accuracy depends on infrastructure properties - asymmetry in outgoing and incoming communication delay affects systematic bias.

**PLEASE NOTE**

It is recommended that dedicated network rather than public network is used for synchronisation purposes.

Factory settings of Ethernet communication are:

IP Address	DHCP (automatically)
TCP Port (Terminal Port)	10001
Subnet Mask	255.255.255.0

PUSH communication settings PC

When PUSH communication mode is used, data can be sent (pushed) to two different servers. Within this setting, all parameters relevant to used servers should be set, as well as data type for sent data, time synchronization source and server response time.

For more information about PUSH communication mode and XML Data format see *Communication modes on page 140 and appendix D on page 180*.

TCP Link 1 and TCP Link 2 PC

IP address

IP address of the server collecting data from devices.

IP port

IP port of the server collecting data from devices.

Data Format

With this setting a required data format for sending data to receiver using PUSH communication mode is set. Currently supported format is XML-smart. For more information about PUSH communication mode and XML data format see *Communication modes on page 140 and appendix D on page 180*.

Response Time (sec)

With this setting a maximum waiting time for acknowledgement of sent data in PUSH communication mode is set. If acknowledgement from a client is not sent within this time, scheduled data will be resend in next push period.

For devices connected in communication network with slow communication speed, values over 10 seconds needs to be selected.

If value lower than 10 second is selected, historical data from recorders are pushed immediately one after another. If value is higher than 10 seconds, automatic time delay length of 10% of set value is integrated between the sent packets.

Display

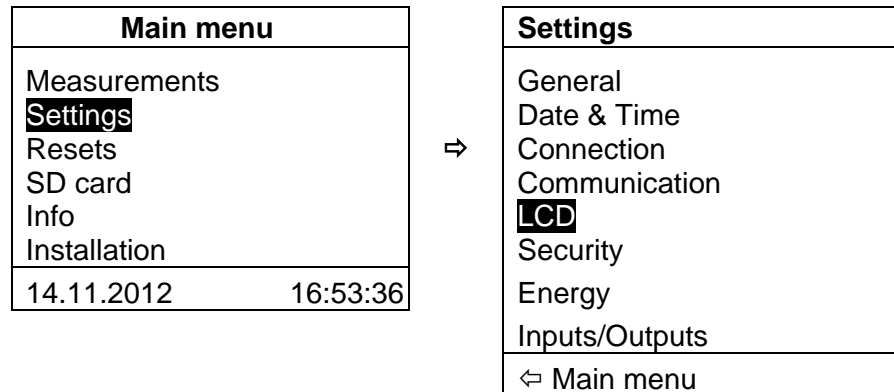

Display settings

A combination of setting of the contrast and back light defines visibility and legibility of a display. Display settings shall be defined in compliance with the conditions in which it will be monitored. Economizing mode switches off back light according to the set time of inactivity.

 **Main menu** ⇒ **Settings** ⇒ **LCD** ⇒ **Contrast / Back light / Back light time off**

Demo cycling period

For demonstration purposes it is useful for device to automatically switch between different displays of measurements.

This setting defines time in seconds for each displayed screen of measurements.

 **Main menu** ⇒ **Settings** ⇒ **LCD** ⇒ **Demo cycling period**

Settings of customized screens

For easier and faster survey of measurements that are important for the user, three different settings of customized screens are available. Each customized screen displays three measurements. When setting customized screens the designations are displayed in shorter form, with up to 4 characters.

Example:

Desired result:

Customized screen 1	Customized screen 2	Customized screen 3	Combined customized screen 4
U1	I _{TOT}	φ_{1-3_RMS}	U1
U _{P-P_avg}	I _{NM}	f	U _{P-P_avg}
U _{UNBALANCE}	I _{AVG}	THD-I1	U _{UNBALANCE}
-	-	-	I _{TOT}
-	-	-	I _{NM}



PLEASE NOTE

Customized screens defined here are selected in menu

Main menu ⇒ **Measurements** ⇒ **Present values** ⇒ **Custom**

Setting can be made only for 3 customized screens. 4th customized screen is showing 5 parameters, three from Customized screen 1 and first two from Customized screen 2. See example above.

Setting:

Main menu ⇒ **Settings** ⇒ **LCD** ⇒ **Custom screen 1 / 2 / 3 / (4)**

Customized screen 1

Custom screen 1		
<u>U</u> 1	I1	P1
OK Select		

Customized screen 2

Custom screen 2		
<u>U</u> 2	I2	P2
OK Select		

Customized screen 3

Custom screen 3		
<u>U</u> 3	I3	P3
OK Select		

Main menu ⇒ **Measurements** ⇒ **Present values** ⇒ **Custom**

229.9 ₃	V	U1
1.000 ₁	A	I1
229.9 ₅	W	P1



398.1 ₇	V	U2
1.500 ₂	A	I2
517.1 ₂	W	P2



398.1 ₇	V	U3
0.980 ₁	A	I3
337.9 ₅	W	P3



U1	229.94	V
I1	1.0001	A
P1	229.97	W -
U2	398.16	V
I2	1.5002	A

Security

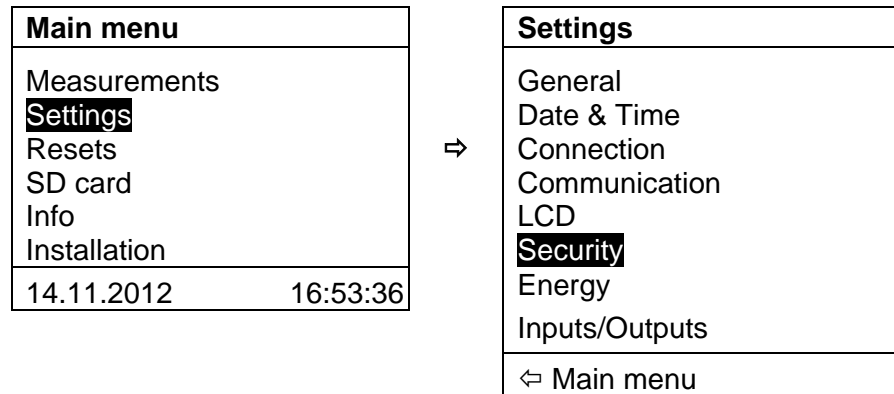

Settings parameters are divided into four groups regarding security level:

PL0 (password level 0)

- Password is not required.
- Available settings:
 - language
 - contrast and
 - LCD back light.

PL1 (password level 1)

- Password for first level is required.
- Available settings:
 - RTC settings
 - Energy meters reset
 - Max. Demand reset
 - Active tariff setting

PL2 (password level 2)

- Password for second level is required.
- Available settings:
 - All settings are available

A backup password (BP) is used if passwords at levels 1 (PL1) and 2 (PL2) have been forgotten, and it is different for each device (depending on a serial number of the device). The BP password is available in the user support department in GOSSEN METRAWATT, and is entered instead of the password PL1 or/and PL2. Do not forget to state the device serial number when contacting the personnel in GOSSEN METRAWATT.



PLEASE NOTE

A serial number of device is stated on the label, LCD (see example below) and is also accessible with MAVO-View software.

The access to the device serial number via a keyboard

Example:

 **Main menu ⇒ Info**



Password setting  

A password consists of four letters taken from the British alphabet from A to Z. When setting a password, only the letter being set is visible while others are hidden.

A password of the first (PL1) and the second (PL2) level is entered, and time of automatic activation is set.

 **Main menu ⇒ Settings ⇒ Security ⇒ Password level 1 / Password level 2 / Password lock time**

Password modification  

A password is optionally modified; however, only that password can be modified to which the access is unlocked at the moment.

Password disabling  

A password is disabled by setting the "AAAA" password.

PLEASE NOTE

A factory set password is "AAAA" at both access levels (L1 and L2). This password does not limit access.



Password and language

Language change is possible without password input. When language is changed from or to Russian, character transformation has to be taken in to account. Character transformation table (English or Russian alphabet) is stated below.

English	A	B	C	D	E	F	G	H	I	J	K	L	M	N	O	P	Q	R	S	T	U	V	W	X	Y	Z
Russian	А	Б	В	Г	Д	Е	Ж	З	И	Й	К	Л	М	Н	О	П	Р	С	Т	У	Ф	Х	Ц	Ч	Ш	Щ

Energy

Main menu	
Measurements	
Settings	
Resets	
SD card	
Info	
Installation	
14.11.2012	16:53:36



Settings
General
Date & Time
Connection
Communication
LCD
Security
Energy
Inputs/Outputs
⇐ Main menu

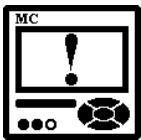

WARNING

Before modification, all energy counters should be read or if energy values are stored in recorders, recorder should be read with MAVO-View software or stored on Memory card to assure data consistency for the past.

After modification of energy parameters, the energy meters (counters) should be reset. All recorded measurements from this point back might have wrong values so they should not be transferred to any system for data acquisition and analysis. Data stored before modification should be used for this purpose.

Active tariff

When active tariff is set, one of the tariffs is defined as active; switching between tariffs is done either with a tariff clock or a tariff input. For the operation of the tariff clock other parameters of the tariff clock that are accessible only via communication or Memory card must be set correctly.

Common energy counter resolution

Common energy counter resolution defines minimal energy that can be displayed on the energy counter. On the basis of this and an Individual counter Resolution, a basic calculation prefix for energy is defined (-3 is $10^{-3}\text{Wh} = \text{mWh}$, 4 is $10^4\text{Wh} = 10 \text{ kWh}$). A Common energy counter resolution also influences a number of pulses for energy of pulse output or alarm output functioning as an energy meter.

Define common energy counter resolution as recommended in table below, where Individual counter Resolution is at default value 10. Values of primary voltage and current determine proper Common energy counter resolution.

Table 8: Suggested Common energy counter resolutions

Current Voltage	1 A	5 A	50 A	100 A	1000 A
110 V	100 mWh	1 Wh	10 Wh	10 Wh	100 Wh
230 V	1 Wh	1 Wh	10 Wh	100 Wh	1 kWh
1000 V	1 Wh	10 Wh	100 Wh	1 kWh	10 kWh
30 kV	100 Wh	100 Wh	1 kWh	10 kWh	10 kWh *

* – Individual counter resolution should be at least 100

Individual counter Resolution PC

The individual counter resolution additionally defines precision of a certain counter, according to settings of common energy counter resolution.

Common energy cost exponent PC

Setting enables resolving the cost display. On the basis of this and a counter divider constant, a basic calculation prefix for energy cost is defined.

Common Tariff Price Exponent and energy price in tariffs PC

Exponent and price represent energy price (active, reactive, common) in a tariff. The tariff price exponent is used for recording the price without decimal places. For example, to set a price for tariff 1 to 0,1567 €/kWh, the number in Price for energy in tariff 1 field should be 1567 and Common tariff price exponent should be -4 ($1567 \times 1E-4 = 0,1567$)

Table 9: An example for 12.345kWh of consumed active energy in the first tariff (price 0,1567 €/kWh)

Common Energy Counter Resolution	1 Wh	100 Wh	100 Wh
Individual Energy Counter Resolution	1	1	100
Common Energy Cost Exponent	-3	-2	0
Common Tariff Price Exponent	-4	-4	-4
Price for energy in Tariff 1	1567	1567	1567
Unit	EUR	EUR	EUR
Example of result, displayed	12.345 kWh 1,934 EUR	12.3 kWh 1.93 EUR	0.01 MWh 1 EUR

Tariff clock

Basic characteristics of a tariff clock:

- 4 tariffs (T1 to T4)
- Separate settings for 4 seasons a year
- Up to 4 time divisions per season in each Day program for tariff switching
- Any combination of valid days in a week or holidays for each program
- Combining of day groups
- Up to 20 settable dates for holidays

Operation of internal tariff clock

Tariff status is displayed in the Info menu.

Example of display for selected Active tariff:

Main menu ⇒ Info

<pre>Tariff status Season: 1 Day programs P1 -- -- -- Tariff: T3 ⇐ Info</pre>	OR	<pre>Tariff status Selected: T2 ⇐ Info</pre>	OR	<pre>Tariff status Tariff input Selected: T1 ⇐ Info</pre>
---	----	--	----	---

Day program sets up to 4 time divisions (rules) for each day group in a season for tariff switching.

A date of real time clock defines an active period. An individual period is active from the period starting date to the first next date of the beginning of other periods.

The order of seasons and starting dates is not important, except when two dates are equal. In that case the season with a higher successive number has priority, while the season with a lower number will never be active.

If no starting date of a season is active, the active period is 1.

If the present date is before the first starting date of any period, the period is active with the last starting date.

Example of season settings:

Season	Season start day
Season 1:	15.02
Season 2:	30.10
Season 3:	–
Season 4:	01.06
Date	Active season
01.01. – 14.02.	2 (last in the year)
15.02. – 31.05.	1
01.06. – 29.10.	4
30.10. – 31.12.	2

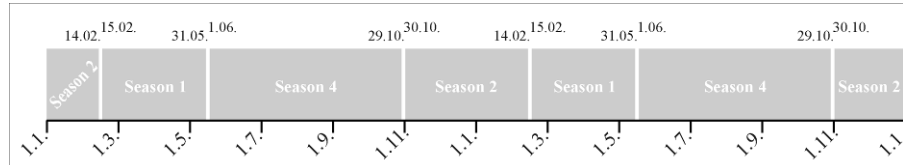

Days in a week and selected dates for holidays define time divisions for each daily group in a period for tariff switching. Dates for holidays have priority over days in a week.

When the real time clock date is equal to one of a dates of holidays, tariff is switched to a holiday, within a period of active daily group with a selected holiday.

If there is no date of holidays that is equal to the real time clock date, all daily groups with the selected current day in a week are active.

Several daily groups can be active simultaneously, which enables more than 4 time divisions in one day (combine of day programs). If the time division is not set for a certain day, tariff T1 is chosen.

Time of a real time clock defines an active tariff regarding currently active day program. A selected tariff T1 to T4 of individual time division is active from the time of the time spot to the first next time of the remaining time divisions.

The order of time divisions is not important, except when two times are equal. In that case the time with a higher successive number has priority (if several time divisions are active, times of higher time divisions have higher successive numbers), while the time division with a lower number will never be active.

If current time is before the first time of any time division of active divisions, the time division with the last time is chosen.

If no time division of active programs is valid, tariff T1 is chosen.

Time selected tariff T1 to T4 or fixed selected tariff (via communication) defines activity of an energy counter.

Counter measured quantity PC

For each of four (4) counters different measured quantities can be selected. User can select from a range of predefined options referring to measured total energy or energy on single phase. Or can even select its own option by selecting appropriate quantity, quadrant, absolute or inverse function.

To energy counter also pulse / digital input can be attached. In this case Energy counter counts pulses from an outside source (water, gas, energy... meter).

I/O modules

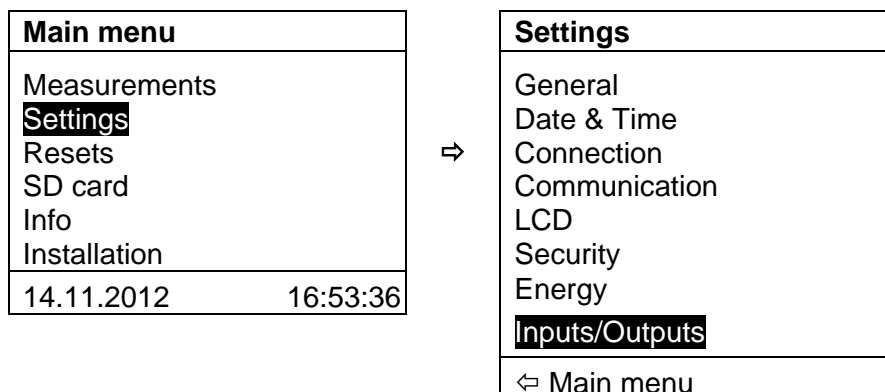

I/O functionality is a powerful tool of **MAVOLOG PRO Quality Analyser**. Using various I/O modules device can be used not only for monitoring main electrical quantities but also for monitoring process quantities (temp., pressure, wind speed...) and for various control purposes.

Device can be equipped with different I/O modules with different functionality. For its technical specifications see chapter *Technical data on page 145*.

Main I/O Modules 1 & 2

MAVOLOG PRO Quality Analyser is equipped with two main I/O slots. The following I/O modules are available:

Table 10: List of available main I/O modules

Module type	Number of modules per slot
Analogue output (AO)	2
Analogue input (AI)	2
Digital output (DO)	2
Digital input (DI)	2
Bistable Digital output (BO)	1
Status output (WO)	1 + 1xDO



PLEASE NOTE

All modules have double input or output functionality, except Bistable alarm output and Watchdog output module. All modules with a double input or output are in MAVO-View presented as two separate modules.

An alarm output and a pulse output can also be selected with the keypad and display. When selecting settings of energy and quadrants for a certain counter, only preset selection is possible, while more demanding settings are accessible via communication. For other modules, information on a built-in module is available via LCD.

Analogue input module

Three types of analogue inputs are suitable for acquisition of low voltage DC signals from different sensors. According to application requirements it is possible to order current, voltage or resistance (temperature) analogue input. They all use the same output terminals.

MAVO-View software allows setting an appropriate calculation factor, exponent and required unit for representation of primary measured value (temperature, pressure, flux...)

Signals from Analogue input can also be stored in built-in memory of a device. They can also be included in alarm function (see chapter *Alarms on page 83*).

DC current range:

Range setting allows bipolar ± 20 mA max. input value

DC voltage range:

Range setting allows bipolar ± 10 V max. input value

Resistance / temperature range:

Range setting allows 2000Ω or 200Ω max. input value

It is also possible to choose temperature sensor (PT100 or PT1000) with direct translation into temperature (-200°C to $+850^{\circ}\text{C}$). Since only two-wire connection is possible it is recommended that wire resistance is also set, when long leads are used.

Pulse input module

Module has no settings. It is general purpose pulse counter from external meters (water, gas, heat ...). Its value can be assigned to any of four energy counters. See chapter *Energy on page 67*.

It can also be used as digital input and included in alarm function to monitor signals from different sensors (see chapter *Alarms on page 83*).

Pulse input module has only one hardware configuration (5...48 V DC).

Digital input module PC

Module has no settings. General purpose is to collect digital signals from various devices, such as intrusion detection relay, different digital signals in transformer station, industry... It is available in three different hardware versions.

It can also be included in alarm function (see chapter *Alarms on page 83*).

Tariff input module PC

Module has no setting. It operates by setting active tariff at a tariff input (see chapter *Tariff clock on page 69* **Fehler! Textmarke nicht definiert.**). The device can have maximal one module with 2 tariff inputs only. With the combination of 2 tariff inputs maximal 4 tariffs can be selected.

Table 11: Active tariff selection table

Active tariff	Signal presence on tariff input	
	Input T1/T2	Input T3/T4
Tariff 1	0	0
Tariff 2	1	0
Tariff 3	0	1
Tariff 4	1	1

Analogue output module PC

Analogue output module is useful for control and measurement visualisation purposes. It can be connected to analogue meters, PLC controllers... It has defined output range 20mA DC. Quantity and shape (up to 6 break points) of an analogue output can be assigned by MAVO-View software.

Output parameter

Output parameter can be any measured value that is required for monitoring, recording, visualisation or control. Value is chosen from a drop-down menu.

Output signal

Output signal can be adjusted to meet all required purposes.

- Shape of output signal (linear, Quadratic)
- Number of break points for zoom function (up to 6)
- Start and End output value

For better visualisation of set output signal parameters, graphical presentation of transfer function is displayed

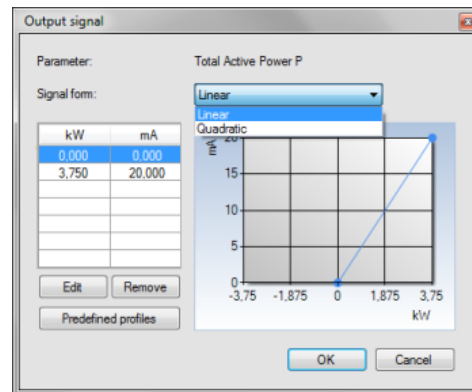

Figure 14: MAVO-View window for output signal definition

For more information, see Help section in MAVO-View software.

Pulse output module

Pulse output is a solid state, optocoupler open collector switch. Its main purpose is pulse output for selected energy counter, but can also be used as an alarm or general purpose digital output.

For description of output functionality see chapter *Functions of Digital output modules* below.

Relay output module

Relay output module is a relay switch. Its main purpose is to be used as an alarm output, but can also be used as a pulse or general purpose digital output.



PLEASE NOTE

A parallel RC filter with time constant of at least 250 μs ($R \cdot C \geq 250 \mu\text{s}$) should be used in case of a sensitive pulse counter. RC filter attenuates relay transient signals.

For description of output functionality see chapter *Functions of Digital output modules* below.

Status (Watchdog) and Relay output module PC

Watchdog and relay module is a combination of two functionalities. One output is used for Watchdog functionality, the other acts as a Relay output module.

The purpose of a Watchdog relay is to detect potential malfunction of device or auxiliary power supply failure. This module can be set for normal operation (relay in close position) or for test purposes to open position (manual activation). After test module should be set back to normal operation.

For description of output functionality see chapter *Functions of Digital output modules* below.

Bistable alarm output module PC

A Bistable alarm module is a relay type. The only difference between relay alarm output and bistable relay alarm output is that it keeps the condition at output in case of device power failure.

Functions of Digital output modules PC

To Digital outputs, Pulse and Relay, different functions can be attached. All can be set with MAVO-View software.

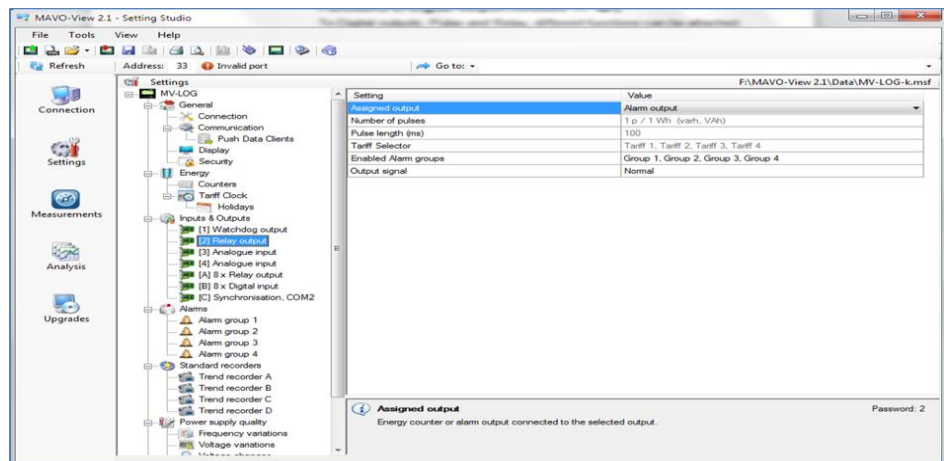

Figure 15: MAVO-View window for digital output definition

Pulse Output of Energy counter

A corresponding Energy counter (up to 4) can be defined to a digital output. A number of pulses per energy unit, pulse length, and a tariff set in which output is active are set.



PLEASE NOTE

Pulse parameters are defined by EN 62053–31 standard. In chapter Calculation of recommended pulse parameters, below a simplified rule is described to assist you in setting the pulse output parameters.

 **Main menu ⇒ Settings ⇒ Inputs/Outputs ⇒ I/O 1 / 2 / 3 / 4 ⇒ (Settings of pulse output)**

Calculation of recommended pulse parameters

Number of pulses per energy unit should be in certain limits according to expected power. Otherwise the measurement from pulse output can be incorrect. Settings of current and voltage transformer ratios can help in estimation of expected power.

Principle described below for pulse setting satisfies EN 62053–31: 2001 standards pulse specifications:

$1,5 \dots 15 \text{ eW} \rightarrow 100 \text{ p} / 1 \text{ eWh}$

e ... exponent (k, M, G)

p... pulses

Examples:

Expected power	→	Pulse output settings
150 – 1500 kW	→	1 p / 1kWh
1,5 – 15 MW	→	100 p / 1MWh
15 – 150 MW	→	10 p / 1MWh
150 – 1500 MW	→	1 p / 1MWh

Alarm Output

If Digital output is defined as an Alarm output, its activity (trigger) is connected to Alarm groups. Multiple alarm groups can be attached to it and different signal shapes can be defined. For more information on how to define alarm groups, see chapter *Alarms on page 83*.

 **Main menu** ⇒ **Settings** ⇒ **Inputs/Outputs** ⇒ **I/O 1 / 2 / 3 / 4** ⇒ **(Settings of alarm output)**

Two parameters should be defined for each alarm output:

- The source for assigned alarm (alarm group 1, 2 or both)
- Type of output signal when alarm is detected.

Output signal types

Normal – A relay is closed as long as condition for the alarm is fulfilled.

Normal inverse – A relay is open as long as condition for the alarm is fulfilled. After that relay goes to closed state

Permanent – A relay is closed when condition for the alarm is fulfilled, and remains closed until it is manually reset.

Permanent inverse – A relay is open when condition for the alarm is fulfilled, and remains open until it is manually reset.

Pulsed – an impulse of the user set length is activated always when condition for the alarm is fulfilled.

Always switched on / off (permanent) – A relay is permanently switched on or off irrespective of the condition for the alarm (general purpose digital output functionality).

Start – When device is switched to aux. Power supply, it need some time to initialize, warm up and self-adjust. During that time operation is not regular. When alarm output is set to *Start* it waits for proper operation of device and only then begins as *Normal* operation.

Check an example in chapter *Alarms on page 83* for graphical demonstration of alarm functionality.

General purpose digital output

This functionality allows user to enable / disable digital output by software settings for example from SCADA system.

For this operation MODBUS registers need to be accessed by means of software. By modifying appropriate MODBUS registers (from SCADA) digital output can be set or reset.

For corresponding MODBUS registers and their values see table below.

Table 12: MODBUS registers and their values for remotely driving digital outputs

MODULE NUMBER	MODBUS REGISTER	REGISTER VALUE	
Module 1 (if installed)	40722	3 - ON	4 - OFF
Module 2 (if installed)	40725	3 - ON	4 - OFF
Module 3 (if installed)	40728	3 - ON	4 - OFF
Module 4 (if installed)	40731	3 - ON	4 - OFF

Tariff Output

Digital output module can act also as a tariff clock output. Different tariffs can be defined to trigger delay. For tariff clock settings see chapter *Tariff clock* on page 69.

Auxiliary I/O Modules A & B

MAVOLOG PRO Quality Analyser is equipped with two auxiliary I/O slots. The biggest difference in functionality between main and auxiliary I/O modules is in response time. Digital inputs and outputs do not have as fast response time as with main I/O modules.

The following auxiliary I/O modules are available:

Table 13: List of available auxiliary I/O modules

Module type	Number of modules per slot
Digital output (DO)	8
Digital input (DI)	8

State of the built in input and/or output module can be monitored also via LEDs on the front panel of the device.

Digital input module

Module has no settings. Their purpose is to collect digital signals from various devices, such as (intrusion detection relay, different digital signals in transformer station, industry...).

According to input voltage range it is available in three different hardware versions. For technical specifications see chapter *Technical data on page 145*.

Digital input can also trigger an alarm (see chapter *Alarms on page 83*).

State of digital inputs can also be monitored for control purposes with SCADA system by reading appropriate MODBUS registers.

Relay output module

Relay output module is a relay switch. Its main purpose is to be used as an alarm output.

For the difference to Relay output module of main I/O module 1 or 2, only a single alarm can be connected to each output (with Relay output module of main I/O module 1 or 2, combination of alarm groups can be connected to each output) to trigger it. For additional information regarding alarms, see chapter *Alarms on page 83*.

RTC Synchronization module C

In order use Module C for synchronisation purposes it has to be defined as a synchronisation source. See chapter *Real time synchronisation source on page 48*.

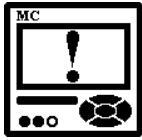

CAUTION

RTC synchronisation is essential part of Class A instrument. If no proper RTC synchronisation is provided device operates as Class S instrument.

Quality Analyzer **MAVOLOG PRO** supports three types of RTC synchronization:

- GPS time synchronisation (via Synchronisation module C)
- IRIG-B time synchronisation (via Synchronisation module C)
- NTP time synchronisation (via Ethernet module)

Instructions regarding connection of Synchronisation module C can be found in chapter *Connection of Synchronisation module C* on page 29.



PLEASE NOTE

Serial communication built in Synchronisation module C can, under certain conditions, be used as an independent secondary communication.

GPS time synchronization

For proper GPS synchronisation two signals are required.

- 1pps with TTL voltage level and
- NMEA 0183 coded serial RS232 communication sentence

GPS interface is designed as 5 pole plugable terminal (+5V for receiver supply, 1pps input and standard RS232 communication interface).

Proposed GPS receiver is GARMIN GPS18x



PLEASE NOTE

When connecting GPS to serial RS232 communication interface please take into consideration required communication parameters. For proposed GPS receiver default communication speed is 4800 b/s.

IRIG time code B (IRIG-B)

Unmodulated (DC 5V level shift) and modulated (1 kHz) serial coded format with support for 1pps, day of year, current year and straight seconds of day as described in standard IRIG-200-04.

Supported serial time code formats are IRIG-B007 and IRIG-B127. For technical specifications see chapter *Technical data on page 145*.

Serial communication (COM2)

If device uses RTC synchronisation over NTP server (via Ethernet module), IRIG-B or only 1PPS without date synchronisation, serial communication port of RTC Synchronisation module C is free to be used as a secondary communication port COM2. Either RS232 or RS485 communication can be used. COM1 and COM2 are completely independent and can be used for the same purpose and at the same time.

Module settings define parameters, which are important for the operation in RS485 network or connections with PC via RS232 communication.

Factory settings for serial communication COM2 are

MODBUS Address	#33	address range is 1 to 247
Comm. speed	4800	speed range is 2400 to 115200
Parity	none	
data bits	8	
stop bits	2	



PLEASE NOTE

By default, addresses of COM1 and COM2 are the same (#33). In this case, change of COM1 address sets COM2 to the same address. When COM1 and COM2 addresses are not equal, change of COM1 address has no influence on COM2 address and change of COM2 address has no influence on COM1 address.

Settings of RTC Synchronisation module C

In order to enable synchronisation with GPS or IRIG time code a proper Real Time synchronisation source should be defined as described in a chapter General settings/Real Time synchronisation source on page 48.

Alarms

Alarms are used for alarming exceeded set values of measured quantities and quantities from different input modules.

Alarms can also trigger different actions according to their settings:

- Visual (alarms cause special alarm LED to lit)
- Sound (alarms can cause sound signalisation)
- Relay switch (alarms can switch digital outputs on main and aux. I/O modules)

Alarm condition can be set for any measured quantity, also for quantities measured on Analogue inputs or signals from Digital / Pulse input.

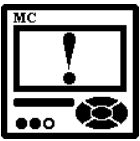

CAUTION

New values of alarms are calculated in percentage. At every modification of connection settings crosscheck if set alarm values are correct.

Alarms PUSH functionality PC

When PUSH communication mode is active, all alarms can be sent (pushed) to a predefined location inside local or wide area network. Settings allow choosing an appropriate destination for alarm data to be sent.

Alarm data is sent to the server immediately as alarm(s) occur. If they cannot be sent immediately due to communication problems, they are sent at next alarm event or data sending interval (whichever occurs first).

Alarms and time stamps of occurrence are also stored into internal memory.

For more information about PUSH functionality and XML data format see chapter *PUSH Communication mode* on page 140 and appendix D on page 180.

Push data to link

When PUSH communication mode is used a data receiving server (client) link should be defined. Data can be sent (according to a type of used communication interface) to COM1, TCP link 1 or TCP link 2. For definition of PUSH links see *PUSH communication settings* on page 140.

Alarms are unlike recorded values sent to chosen link immediately after occurrence. Therefore settings for pushing period and time delay are not applicable.

Alarm statistics reset

This setting is only for resetting online alarms statistics displayed in MAVO-View software.

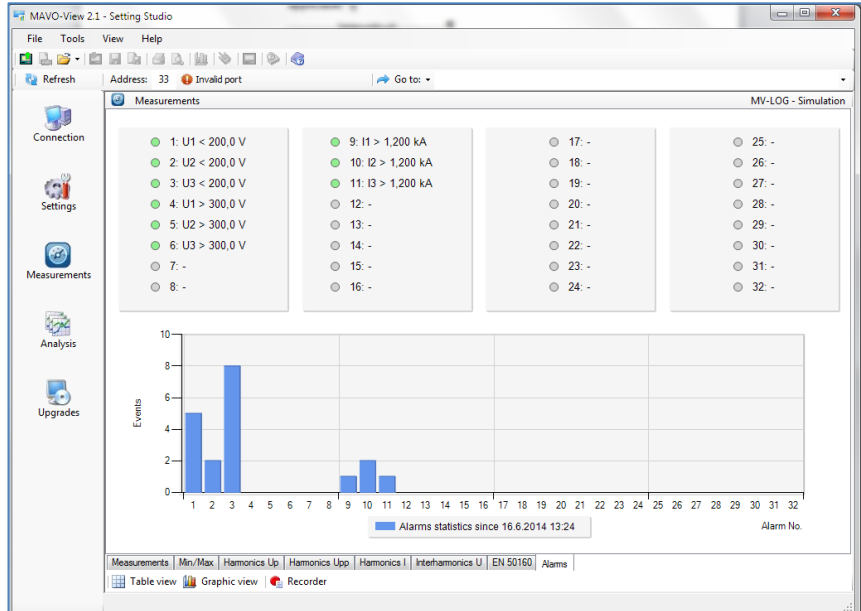

Figure 16: Alarms statistics for showing graphical representation of frequency of alarms occurrence

Alarms group settings PC

Quality Analyser MAVOLOG PRO supports recording and storing of 32 alarms that are divided into 4 groups of 8 alarms. Each group of alarms has some common settings applicable for all alarms within this group.

MD Time constant

Sets a thermal mode maximum demands time constant for the alarm group.

When monitoring certain quantity it is possible to monitor its actual value or its max. demand value. If latter is chosen then a time constant for calculation of thermal mode max. demand value should be set.

This setting is for alarm purposes only and is independent of max. demand calculation settings for monitoring and recording purposes as described in chapter *Maximum demand calculation* on page 122.

Compare time delay

This setting defines delay time (if required) between satisfying the alarm condition and alarm activation. If alarm condition is shorter then this setting alarm will not be triggered.

This setting is used to rule out sporadic and very short duration triggers.

Hysteresis

This setting defines alarm deactivation hysteresis.

When monitored quantity is close to set limit line its slight variation can trigger numerous alarms.

Hysteresis should be set according to estimated variation of monitored quantity.

Response time

This setting defines alarm response on monitored quantity.

Normal response: In this case monitored quantity is averaged according to display averaging settings (0.1 to 5s – see chapter *General settings / Average interval* on page 46)

Fast response: In this case alarms react on non-averaged measurements (1 signal period).

This setting should be used according to required functionality. Fast response is more prone to glitches and transient effects in a system but reaction time is fast.

Individual alarm settings 

For each individual alarm different settings are possible.

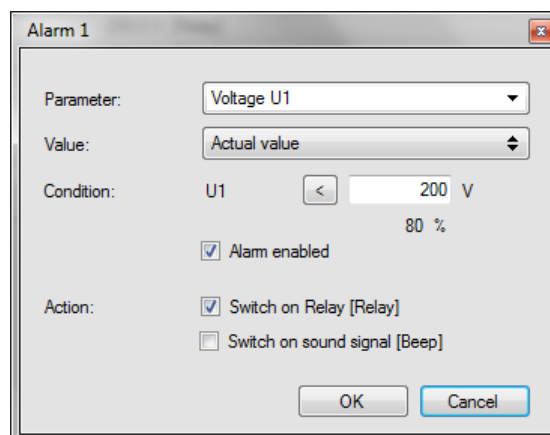

Figure 17: Individual Alarms settings

Parameter

This setting defines a quantity that should be monitored. It is also possible to select process quantities from I/O modules.

Value

For chosen monitoring parameter an actual value or MD (maximum demand) value should be set.

Condition

It is a combination of a logical operator “Higher than” or “Lower than” and a limit value of the condition. For digital / pulse input it is possible to set condition is “Is high” or “Is low”.

Action

This section is consists of checkboxes that applies different functions to individual alarms.

Switch on Relay checkbox can be selected if user wants this alarm to trigger output(s) that are connected to its group of alarms (pulse, relay or bistable output module). This action only applies to I/O modules 1 and 2. To relay outputs of I/O module A or B only single alarm can be attached. In this case Switch on Relay setting has no influence.

Switch on sound signal checkbox would activate built in beeper if this alarm is active.

Alarm enabled checkbox, activates alarm setting.

Types of alarms

Visual alarm

When alarm is switched on, a red LED on the device front side is blinking (see figure shown on next page).

Sound alarm

When alarm is switched on, an audible alarm is given by the device (a beep). It can be switched off by pressing any key on the front plate (see figure shown on next page).

Alarm output (pulse) – setting made for I/O module 1 and 2

According to the alarm signal shape the output relay will behave as shown below.

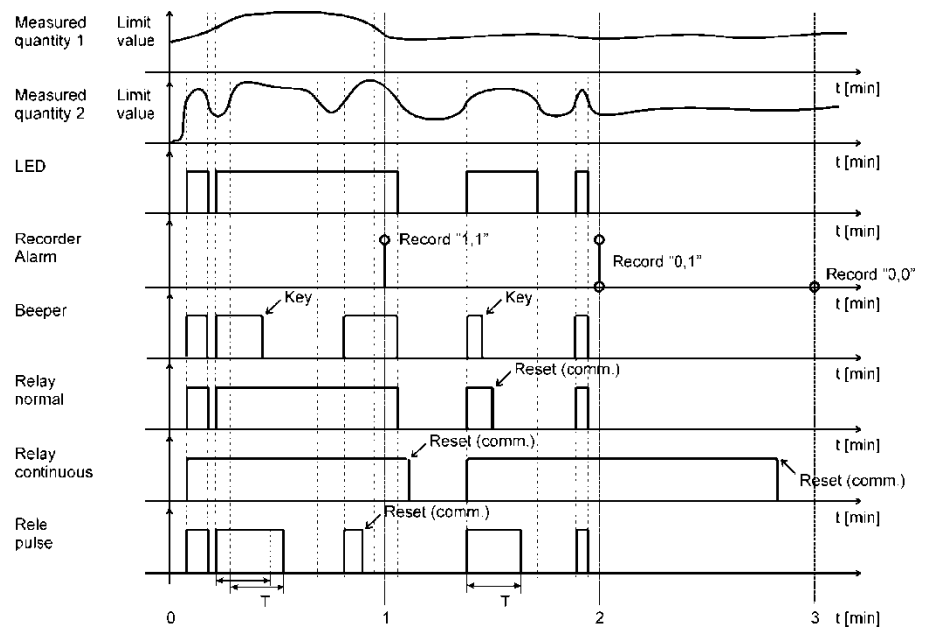

Figure 18: Graphical presentation of alarms operation

Internal Memory

Measurements, alarms, PQ reports and details can be stored in a built in memory of Quality Analyser **MAVOLOG PRO** 8 MB flash. This amount of memory suffices for storing EN 50160 compliant PQ reports with details for more than 12 month. All records stored in memory are accessible by communication or memory card and can be displayed with MAVO-View software.

Device has also a built in function that enables scheduled transmission of data, stored in memory, to remote data collecting system. For more information regarding this feature see chapter *PUSH Communication mode* on page 140.

Memory organisation PC

Devices' internal memory has 8 MB of total memory space. It is divided into 5 partitions which size is defined by the user and 2 fixed partitions.

User defined partitions are A, B, C and D recorders that are intended for recording of measurements (each recorder can store up to 32 parameters), while all alarms that occurred are recorded in an alarm partition.

Fixed partitions are dedicated for recording PQ reports and details (see chapter *Conformity of voltage with EN 50160 standard* on page 93).

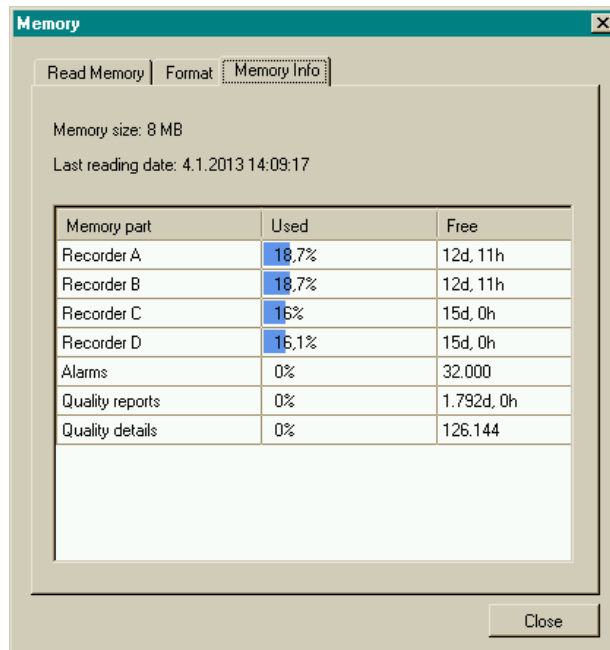

Figure 19: Internal memory organisation

Memory operation

Memory functions in a cyclic mode in compliance with the FIFO (first in - first out) method. This means that only the latest records are stored in the memory that will replace the oldest ones.

A size of stored data or a storing period depends on selected partition size, a number of recorded quantities and a storage interval.

Storage availability of partitions is shown in the Information menu (see chapter *Display of device info on page 36*).

Memory clearing

There is usually no need to clear the memory, because it works in cyclic mode. If it is required anyway, the data storing must be stopped first. Read the device settings with MAVO-View and set “Recorder state” in Memory setting group to “stopped” as shown in a figure below.

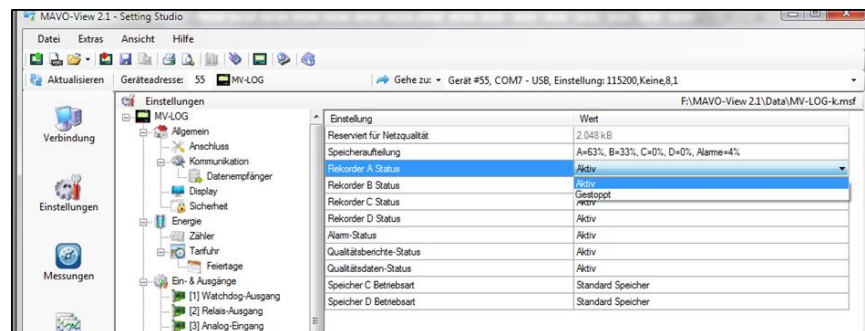
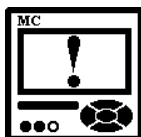

Figure 20: Enabling or disabling data storage

Download changes to the device and open Memory info form (Figure 19 on previous page) and Format tab. Choose memory partitions required to be cleared and click format button. After partitions are cleared set “Recorder state” setting back to active.

CAUTION



It is strongly advised to download recorder data before applying any changes to recorder or changes of settings for energy, type of connection, current and voltage transformer settings and used current and voltage ranges. These changes might have impact on recorded history so data might no longer be valid.

General purpose recorder settings PC

General purpose recorder consists from 4 partitions (A, B, C and D). General purpose recorder does not include alarm recorder nor PQ reports and details recorder. Separately, for each of four partitions, following settings can be set:

Storage interval

Storage interval sets a time interval for readings to be recorded.

Which type of parameter should be stored each interval (avg., min., max., momentary...) is defined in settings for each individual parameter described later in this chapter.

MD Time constant

When max. demand needs to be recorded, this setting sets a period for calculation of maximum and minimum value in thermal mode (Minimum (MD) or Maximum (MD)). Different parameters can be set for Recorded parameters 1-8, 17-24 and 9-16, 25-32. This setting is only available for recorders A and B.

PUSH settings

When PUSH communication mode is active, all measurements which are set to be written to the memory can be sent (pushed) to a predefined location inside local or wide area network (from the time that PUSH functionality has been activated, not for the past records).

Settings allow choosing an appropriate destination for data to be sent, time interval of sent data and a delay time for sending data if they cannot be sent immediately due to restrictions in network.

For more information about PUSH functionality and the XML data format see chapter *PUSH Communication mode on page 140*.

Recorded quantities

For each measurement, which is to be recorded it is possible to set a required quantity and its type within storage interval.

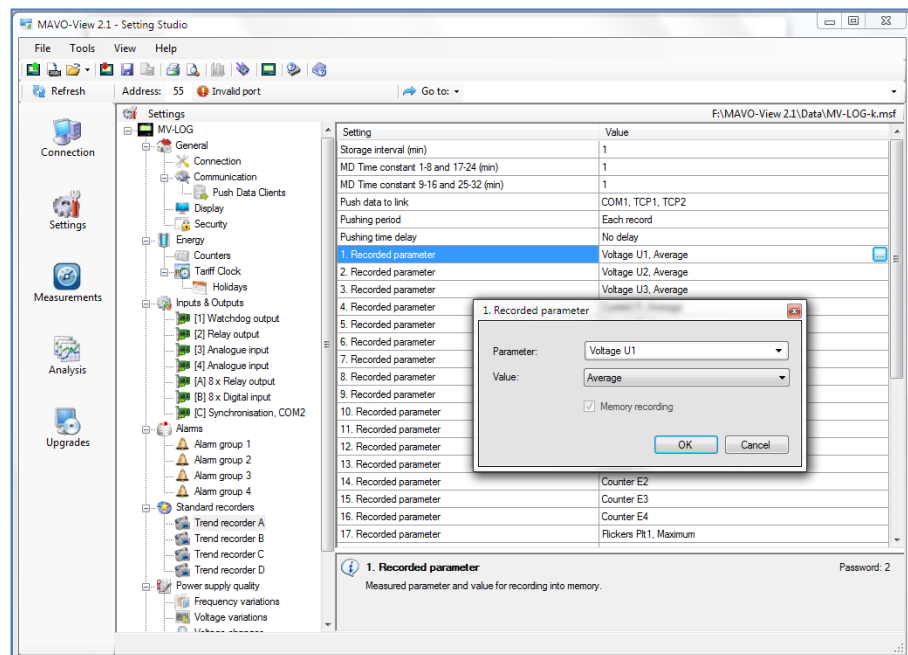

Figure 21: Stored parameter settings

Parameter

Here monitoring quantity can be selected from a list of supported measurements.

Besides primary electrical quantities also auxiliary quantities from input modules can be selected.

Value

A type of a selected quantity within set monitoring interval can be set to different conditions.

- *Minimum and Maximum value* represents minimum or maximum of recorded averaged values within selected storage interval. Note that min./max. value is not a single period value but an average (0.1 s to 5 s; see chapter *General settings / Average interval on page 46*).
- *Minimum (MD) and Maximum (MD) value* represents calculation of a MD value with applied thermal function. Thermal function time constant is described above (MD Time constant). It applies only to recorders A and B.

- *Average value* represents calculated average value within selected storage interval.
- *Momentary value* represents first momentary value within selected storage interval. Note that momentary value is not a single period value but an average (0.1 s to 5 s; see chapter *General settings / Average interval on page 46*). It applies only to recorders C and D.
- *Minimum and Maximum (Period) values* represent min. or max. value within selected storage interval calculated in a single period. This function allows recording of very fast changes. It applies only to recorders C and D.

Conformity of voltage with EN 50160 standard

The EN 50160 standard deals with voltage characteristics of electricity supplied by public distribution systems. It specifies the limits or values of voltage characteristics in normal operation within public low or middle voltage system network. Following this definition the **MAVOLOG PRO Quality Analyser** is adapted for monitoring voltage characteristics of a distribution systems according to EN 50160 standard. Together with setting and monitoring software MAVO-View voltage characteristics can be monitored and weekly reports about power quality are issued.

Based on requirements stated in the standard, default parameters are set in the device according to which supervision of all required characteristics is performed. Parameters can also be changed in detailed settings for individual characteristics.

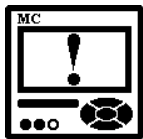

CAUTION

Factory default settings for PQ characteristics are in compliance with standard EN 50160. By changing individual parameters conformity of weekly reports with this standard is no longer valid.

Parameters of PQ characteristics are settable only by means of setting software MAVO-View.

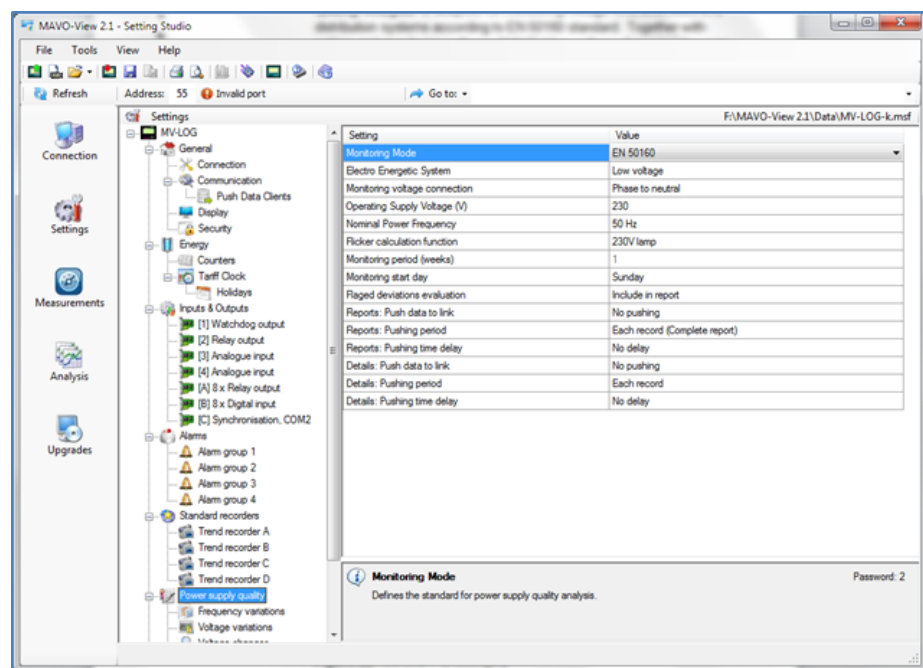

Figure 22: General PQ settings

General PQ settings

General PQ settings are basic parameters that influence other settings.

Monitoring mode

Monitoring mode can be set to:

- EN 50160: Monitoring according to EN 50160 enabled. Weekly reports are issued according to set parameters
- No monitoring: Weekly reports for network compliance with the standard are disabled

Electro energetic system

Requirements for PQ monitoring differ regarding type of a monitored public distribution system. Therefore it is essential to choose proper type. This setting influences some of the predefined limit lines according to relevant standard EN 50160.

MAVOLOG PRO Quality Analyser can monitor PQ within following systems:

- Low Voltage grid connected system
- Medium Voltage grid connected system
- Low Voltage islanded system
- Medium Voltage islanded system



PLEASE NOTE

Choosing one of listed distribution systems automatically sets PQ characteristics according to requirements in EN 50160 for that particular system.

Nominal supply voltage

Set a voltage level of a monitored system. This value is used as a reference for calculation of power quality indices and is usually equal to nominal network voltage (also marked as U_{din} in various standards). Factory default value is EU standard low voltage value 230 V.

Nominal power frequency

Nominal frequency of monitored supply voltage is selected. Factory default value is EU standard frequency 50Hz. It is also possible to choose 60 Hz.

Flicker calculation function

Low voltage level for residential lamps can be either 230V or 110V. Function for detection of flicker differs regarding this voltage. Since actual low voltage level can be different as secondary voltage of used VT (nominal measuring voltage) this setting must be set to a voltage level, which is used to supply residential lamps.

Monitoring period (weeks)

Monitoring period predefines period for issuing PQ reports. When Monitoring Mode is set to EN 50160, monitoring is performed continuously.

This setting defines how often should reports be issued.

Monitoring start day

A starting day in a week for monitoring period is selected. It starts at 00:00 (midnight) in the selected day. The selected day will be the first day in a report.

After Monitoring period and Monitoring start day are defined, PQ reports will be continuously issued at the end of each monitoring period. All reports and associated anomalies within monitored period are stored in devices internal memory and can be analysed by means of MAVO-View software.

Flagged events setting

Flagged events setting specifies actions on data (recorded events) that has been flagged (marked) according to flagging concept IEC 61000-4-30.

Flagged data are power quality records, which has been influenced by one or more voltage events (interruptions, dips, swells).

The purpose of flagging data is to mark recorded parameters when certain disturbances might influenced measurements and caused corrupted data. For example, voltage dip can also trigger occurrence of flicker, interharmonics... In this case all parameters which were recorded at a time of voltage events are marked (flagged). In later evaluation those flagged records can be omitted from final report by choosing appropriate setting.



PLEASE NOTE

Regardless of this setting, readings will be always stored in recorder and available for analysis. Flagging only influences PQ reports as a whole.

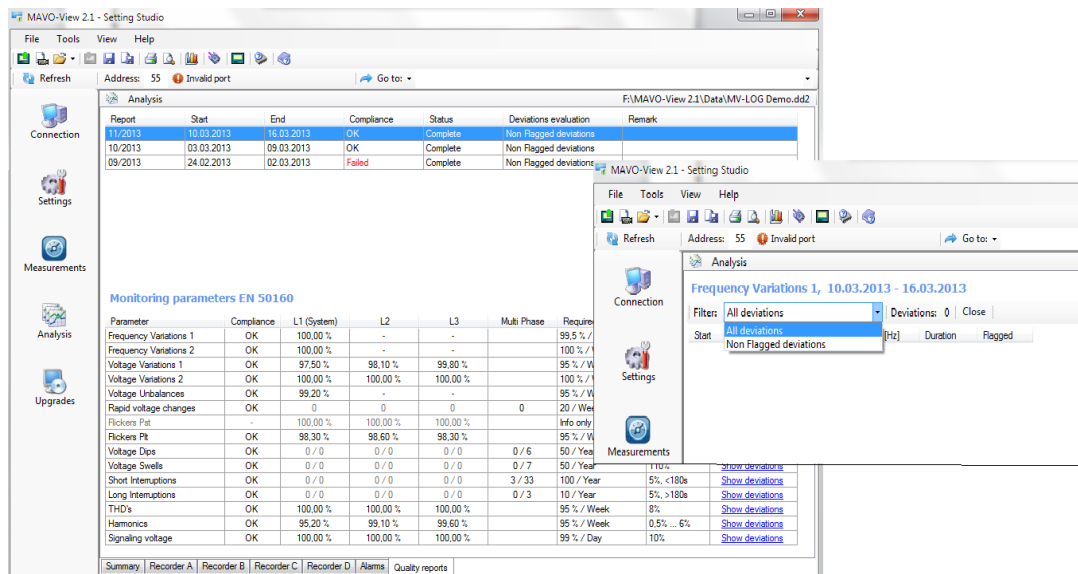

Figure 23: Flagged data can be included or excluded from a PQ report

Sending Reports and Report Details

When PUSH communication mode is active, reports about quality and report details for each parameter can be sent (pushed) to a predefined location inside local or wide area network. Settings allow choosing an appropriate destination for data to be sent, time interval of sent data and a delay time for sending data if they cannot be sent immediately due to restrictions in network.

For more information about PUSH Communication mode see page 140.

EN 50160 parameters settings

Table 13: Power Quality indices as defined by EN 50160

Phenomena	PQ Parameters
Frequency variations	Frequency distortion
Voltage variations	Voltage fluctuation Voltage unbalance
Voltage changes	Rapid voltage changes Flicker
Voltage events	Voltage dips Voltage interruptions Voltage swells
Harmonics & THD	THD Harmonics Inter-harmonics Signalling voltage

Standard EN 50160 describes in details PQ parameters and corresponding limit lines for monitoring whereas distribution system voltage operates in accordance with mentioned standard.

Settings of limit lines and required percentage of appropriate indices resembles requirements of standard EN 50160.

When monitoring according to this standard is required there is no need to make changes to PQ parameters settings.

More detailed description of certain parameter monitoring procedures is in a chapter *Measurements*.

There are some PQ parameters which are interesting for monitoring but are not required to be part of PQ reports. These settings do not have standardised limit values and can be set according to distribution network requirements.

- Short term flicker (limit Pst = 1)
- Interharmonics (10 values of user defined frequencies)

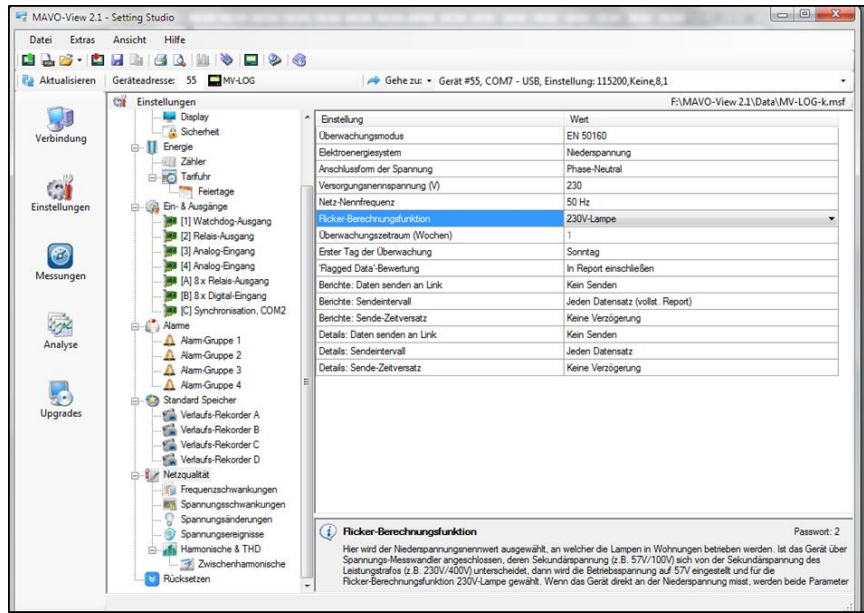

Figure 24: Settings for power quality parameters are set with setting and monitoring software MAVO-View

MAVO-View HELP description clearly marks PQ parameters, which are not required as a part of EN 50160 PQ report.

Below figure shows settings for interharmonic values:

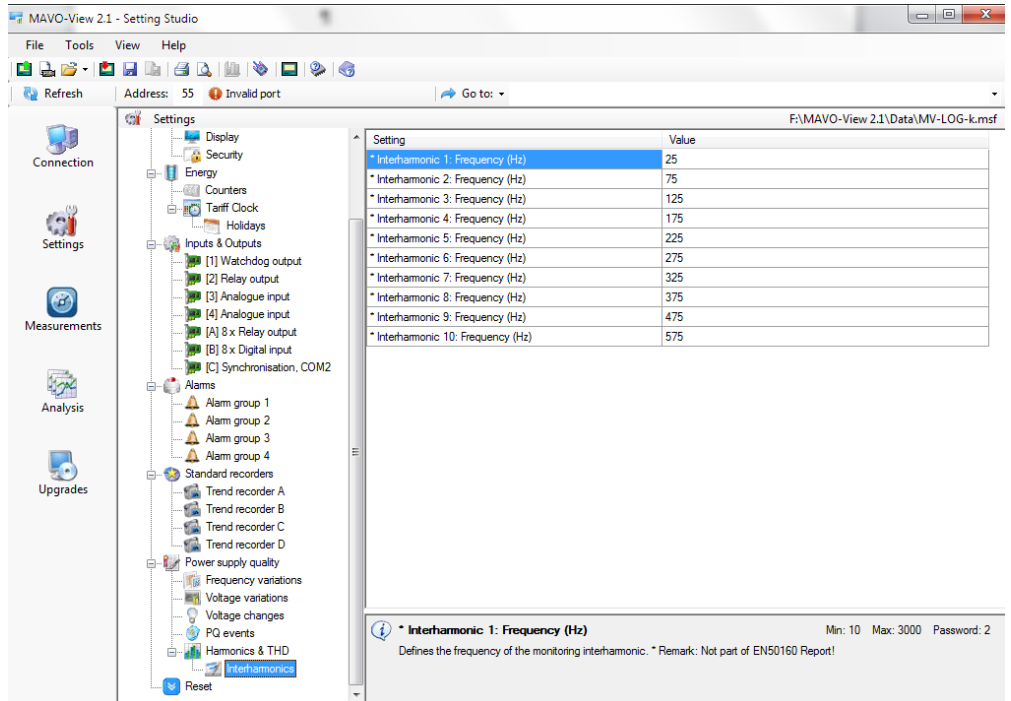



Figure 25: Settings for 10 user defined interharmonic frequencies

Reset operations

During normal operation of a device different counter s values need to be reset from time to time.

Reset energy counters (E1, E2, E3, E4)

All or individual energy meters (counters) are reset.

 **Main menu** ⇒ **Resets** ⇒ **Energy counters** ⇒ **All Energy counters**
/ **Energy counter E1 / E2 / E3 / E4**

Reset energy counters costs (E1, E2, E3, E4)

All or individual energy costs are reset.

 **Main menu** ⇒ **Resets** ⇒ **Energy counters** ⇒ **All Cost counters /**
Cost counter E1 / E2 / E3 / E4

Reset maximal MD values

Thermal mode

Current and stored MDs are reset.

Fixed interval / Sliding windows

The values in the current time interval, in all sub-windows for sliding windows and stored MD are reset. In the same time, synchronization of time interval to the beginning of the first sub-window is also performed.

 **Main menu** ⇒ **Resets** ⇒ **MD values**

Reset the last MD period

Thermal mode

Current MD value is reset.

Fixed interval / Sliding windows

Values in the current time interval and in all sub-windows for sliding windows are reset. In the same time, synchronization of the time interval is also performed.

 **Main menu** ⇒ **Resets** ⇒ **Last period MD**

Synchronize MD

Thermal mode

In this mode, synchronization does not have any influence.

Fixed interval / Sliding windows

Synchronization sets time in a period or a sub-period for sliding windows to 0 (zero). If the interval is set to 2, 3, 4, 5, 6, 10, 12, 15, 20, 30 or 60 minutes, time in a period is set to such value that some intervals will be terminated at completed hour.

Example:

Main menu ⇒ Resets ⇒ Synchronize MD

Time constant (interval)	15 min	10 min	7 min
Synchronization start time	10:42	10:42	10:42
Time in a period	12 min	2 min	0 min
First final interval	10:45	10:50	10:49

Alarm relay (1 or 2) Off

Turn off the alarm (relay output).

Main menu ⇒ Resets ⇒ Reset alarm status

Reset Min / Max values

All Min / Max values are reset.

Main menu ⇒ Resets ⇒ Reset Min. Max. values

Reset alarm statistic

Clears the alarm statistic. It can be made by MAVO-View software under Alarm settings. This setting is only for resetting online alarms statistics displayed in MAVO-View software.

Settings and memory card

Quality Analyser **MAVOLOG PRO** is provided with a built in slot for a full size SD memory card that is used for measurements transfer from internal memory, device setting and software upgrading. The memory card shall be formatted with the FAT16 file system.

Directory structure on a memory card

A structure of directories is defined and enables correct data handling via a memory card. The memory card shall contain the following directories and files:

- DATA
- SETTING
- UPGRADE
- File: Automenu.txt (option)

DATA

Records from the internal memory are collected in the DATA directory. To upload data of several devices to the memory card, each device checks and, if necessary, creates its own subdirectory before data transfer. Each subdirectory uses a device serial number as its name and stores files with data in it. Each file name contains date (year, month and day) and a record sequence number of that day.

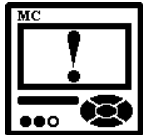

WARNING

When uploading data file to memory card and there is a file with sequence number 99 of that day, a file with sequence number 00 is generated. File with sequence number 00 of that day, is overwritten in case of any further uploading data that day.

SETTING

Settings are stored in the directory using two recording modes:

- With a type designation and a sequence number from 1 to 9
- With an device serial number

UPGRADE

A file with upgrades is available for upload with the MAVO-View software. A file has a name of a corresponding device type designation and suffix fl2 (e.g. **MAVOLOG PRO.FL2**).

Automenu.txt

For faster and easier upgrading of the firmware there is »Automenu.txt« file in the root directory. When an memory card with a file is inserted and if upgrade version is higher, display automatically jumps into the memory card menu and suggests the Software upgrade menu, otherwise it automatically jumps into the Save data menu. When upgrading is finished and the OK key is pressed and memory card is removed, the menu that was displayed before inserting the memory card is displayed.

Automenu.txt file can be created by the user by means of the text editor. A new file has to be opened and saved under the correct name (Automenu.txt) and without content.

Example:

```

DATA
↳      MC003973
        ↳      06050301.MMC
        MC003974
        ↳      06050301.MMC
        06070301.MMC
        MC009424
        ↳      06060301.MMC
        06070301.MMC

SETTING
↳      MC003973.MSF
        MAVOLOG
        PRO-1.MSF
        MAVOLOG
        PRO-2.MSF

UPGRADE
↳      MAVOLOG
        PRO.FL2

Automenu.txt
    
```

Handling memory card

Quality Analyser is on the front panel equipped with a slot for a Memory card. Slot is protected with a protection cover that can be simply removed before inserting the card. The protection cover shall be fixed back after work is done.

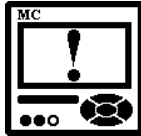

CAUTION

While memory card activity LED is blinking it should not be pulled out of the slot.

Memory card information

Device checks a file system and capacity of the inserted memory card.

 Main menu ⇒ SD card ⇒ SD info

Save data

Sections

For each section define whether it is included for a record in a file.

Date

Since the last transfer, all available data from the last official reading with a password is included. For the Last week and the Last month, all data of the last complete unit (a week, a month) with the beginning in the first day at 00:00 is included. The selected date defines a day with the beginning at 00:00 from which further on to the current time of data transfer. When all data is selected, all data for an individual section, that are stored in the memory up to the moment when reading is started, are transferred.

Official reading

If official reading is selected date of reading is stored in device, and is applied at the next official reading.

Example:

 Main menu ⇒ SD card ⇒ Save data

<pre>Save data ✓ Recorder A ✓ Recorder B ✓ Alarms ✓ Q. Details ✓ Q. Reports ⇒ Change</pre>	OK	<pre>Save data Since last transfer Last week Last month Custom date All data ⇒ MMC card</pre>	⇔	<pre>Save data Official transfer No Yes ⇒ MMC card</pre>
<pre>Save data Capacity : 250 MB Free : 233 MB File : 972 kB DATA\MC000003\ 06070401.MMC OK Start</pre>	OK	<pre>Save data 06070401.MMC Transferring... 350kB/ 968kB [Progress bar] ⇒ Cancel</pre>	<pre>Save data 06070401.MMC 968kB/ 968kB [Progress bar] Press OK</pre>	

Save settings

File of current device settings is stored in SETTING directory. File name consists of device serial number and MSF extension. In case of file already stored on memory card, the device warns if file should be overwritten.

Load settings

For loading settings, the files that correspond to the device type are displayed on LCD. When a file is selected, it is necessary to choose the segments of settings that will be overwritten. A number of registers that will be modified is written next to each segment. After settings transfer, a warning on errors could be displayed. Errors occur when the module setting and a memory capacity differ from the used ones in the device. A number of settings (registers) that do not match and are neither modified is displayed after warning.

Basic settings

At transfer of basic settings, settings of connections, ratios, used voltage and current ranges as well as nominal frequency are not changed. New settings can influence energy counters if recorded in a memory.

Alarms

Settings of all alarms are changed, but old alarms with previous settings remain in the memory.

Recorders

Recorder overwriting enables modified setting of connection, ratio, used voltage and current ranges as well as nominal frequency. All other data in a memory is lost.

Example of a display on LCD for MAVOLOG PRO:

Main menu ⇒ SD card ⇒ Load settings

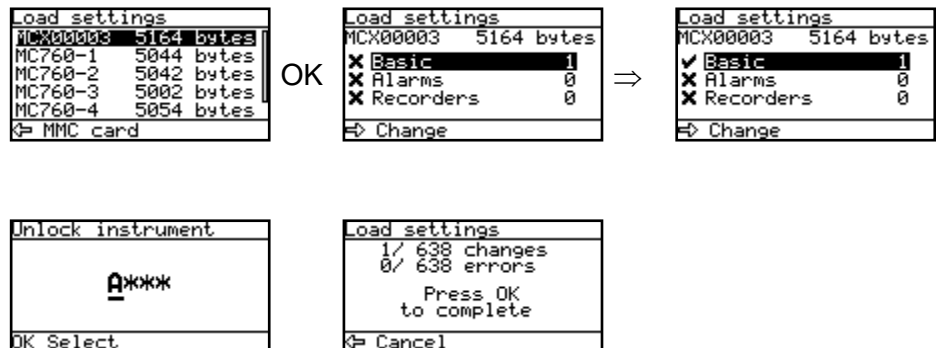

Firmware upgrading

Before upgrading files on memory card are checked first, this can last some time (approx. 1 minute). When both versions are displayed, upgrade can be performed if the device software version is lower or equal to the version in a file.

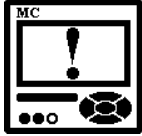

WARNING

When upgrading firmware software remove memory card and do not interrupt power supply - the device could become inoperative!

Repairing of device in this case is to be done by authorized service.

Upgrade error codes:

Error 1: memory card not inserted

Error 2: Error on FAT16 file system

Error 3: File not exist (.fl2)

Error 4: Error in .fl2 file

Error 5: File too long (.fl2)

Error 6: Invalid file (.fl2)

Error 7: Incorrect upgrade version (.fl2)

MEASUREMENTS

MAVOLOG PRO Quality Analyser performs measurements with a constant sampling frequency 32 kHz. Measurement methods differ for normal operation quantities, where values are averaged and aggregated according to aggregation requirements of IEC 61000-4-30 standard (Class A) and voltage events where half-period values are evaluated again according to Class A standard.

INTRODUCTION	107
SELECTION OF AVAILABLE QUANTITIES	109
EXPLANATION OF BASIC CONCEPTS	113
CALCULATION AND DISPLAY OF MEASUREMENTS	115
PRESENT VALUES	116
MIN/MAX VALUES	122
ALARMS	124
HARMONIC ANALYSIS	126
PQ ANALYSIS	130
ONLINE MONITORING	131
PQ RECORDS	134

Introduction

Online measurements

Online measurements are available on display or can be monitored with setting and monitoring software MAVO-View.

Readings on display are performed continuously with refresh time dependent on set average interval whereas rate of readings monitored with MAVO-View is fixed and refreshed approx. each second.

For better overview over numerous readings, they are divided into several groups, which contain basic measurements, min. and max. values, harmonics, PQ parameters and alarms.

Each group can represent data in visually favoured graphical form or detailed tabular form. Latter allows freezing readings and/or copying data into various report generation software tools.

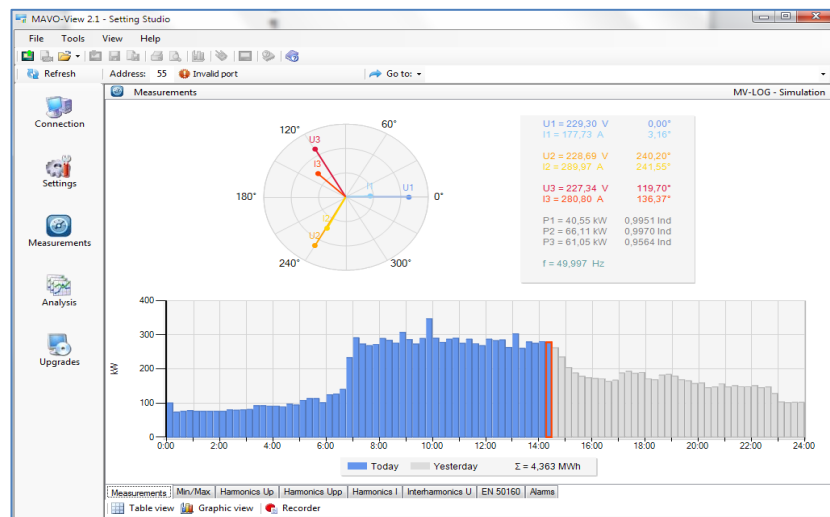

Figure 26: Online measurements in graphical form – phaser diagram and daily total active power consumption histogram

The screenshot displays the 'Measurements' section of the MAVO-View 2.1 software in a tabular view. The table lists various parameters with their actual, minimum, and maximum values.

Parameter	Actual	Minimum	Maximum
Voltage U1	229.87 V	221.29 V	233.94 V
Voltage U2	229.24 V	220.77 V	233.61 V
Voltage U3	228.16 V	215.63 V	233.45 V
Phase to phase voltage U12	398.49 V	383.16 V	405.49 V
Phase to phase voltage U23	395.78 V	382.08 V	404.58 V
Phase to phase voltage U31	396.13 V	373.07 V	404.37 V
Current I1	161.01 A	7.8 A	342.6 A
Current I2	267.44 A	7.04 A	407.25 A
Current I3	256.60 A	13.3 A	401.3 A
Active Power P1	36.89 kW	1.24 kW	99.92 kW
Active Power P2	61.12 kW	1.38 kW	92.35 kW
Active Power P3	55.53 kW	2.92 kW	90.20 kW
Total Active Power P	154.55 kW	6.05 kW	653.52 kW
Apparent Power S1	37.00 kVA	1.77 kVA	101.10 kVA
Apparent Power S2	61.30 kVA	1.60 kVA	92.81 kVA
Apparent Power S3	60.54 kVA	3.05 kVA	90.50 kVA
Total Apparent Power S	156.86 kVA	6.65 kVA	656.62 kVA
Frequency f	49.997 Hz	49.876 Hz	54.854 Hz
Internal Temperature	18.0 °C	14.01 °C	32.14 °C
Reset	Date	Time	
Reset Timestamp	17.06.2014	13:11:40	

Figure 27: Online measurements in tabular form

Interactive instrument

Additional communication feature of a device allows interactive handling with a dislocated device as if it would be operational in front of user.

This feature is useful for presentations or product training.

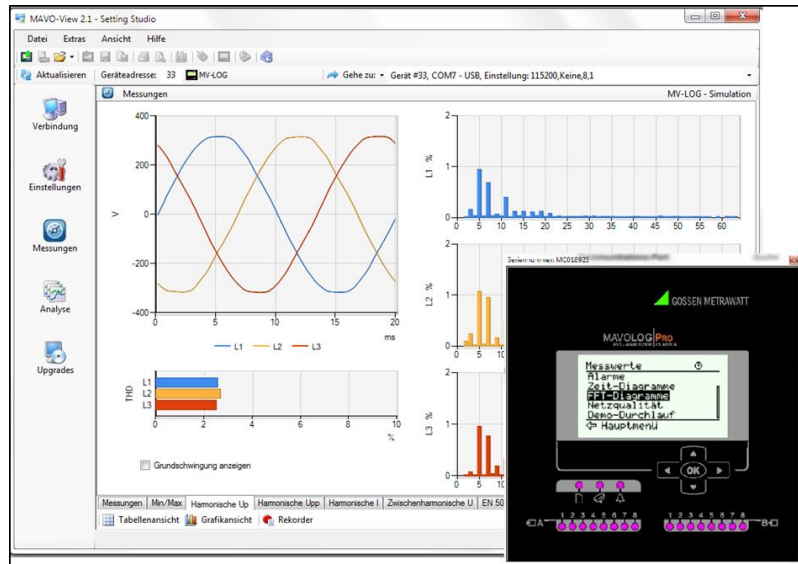

Figure 28: Online harmonic measurements in graphical form and interactive instrument

Selection of available quantities

Available online measuring quantities and their appearance can vary according to set type of power network and other settings such as; average interval, max. demand mode, reactive power calculation method...

Complete selection of available online measuring quantities is shown in a table on the next page.



PLEASE NOTE

Measurements support depends on connection mode the device type. Calculated measurements (for example voltages U_1 and U_2 when 3-phase, 4-wire connection with a balanced load is used) are only informative.



PLEASE NOTE

For 3b and 3u connection mode, only phase to phase voltages are measured. Because of that factor $\sqrt{3}$ is applied to calculation of quality considering nominal phase voltage. For 4u connection mode measurements support is same as for 1b.

Meas. type	Measurement	3-phase 4-wire	3-phase 3-wire	1-phase	comments
Phase measurements	<i>Voltage</i>				
	U_{1-3_RMS}	☑	☑	☑1ph	
	U_{AVG_RMS}	☑	☑	☑	
	$U_{unbalance_neg_RMS}$	☑📖	☑📖		
	$U_{unbalance_zero_RMS}$	☑📖			
	<i>Current</i>				
	I_{1-3_RMS}	☑	☑	☑1ph	
	I_{TOT_RMS}	☑	☑	☑	
	I_{AVG_RMS}	☑	☑	☑	
	<i>Power</i>				
	P_{1-3_RMS}	☑	☑	☑1ph	
	P_{TOT_RMS}	☑	☑	☑	
	Q_{1-3_RMS}	☑📖	☑📖	☑1ph📖	reactive power can be calculated as a squared difference between S and P or as delayed sample
	Q_{TOT_RMS}	☑	☑	☑	
	S_{1-3_RMS}	☑	☑	☑1ph	
	S_{TOT_RMS}	☑	☑	☑	
	PF_{1-3_RMS}	☑	☑	☑1ph	
	φ_{1-3_RMS}	☑	☑	☑1ph	PA – Power angle
	<i>Harmonic analysis</i>				
	$THD-U_{1-3}$	☑	☑	☑1ph	
	$THD-I_{1-3}$	☑	☑	☑1ph	
	$U_{1-3_harmonic_1-63_ \%}$	☑📖	☑📖	☑1ph📖	% of RMS or % of base
	$U_{1-3_harmonic_1-63_ABS}$	☑	☑	☑1ph	
	$U_{1-3_harmonic_1-63_ \varphi}$	☑	☑	☑1ph	
	$U_{1-3_inter-harmonic_ \%}$	☑📖	☑📖	☑1ph📖	monitoring up to 10 different fixed frequencies. % of RMS or % of base
	$U_{1-3_inter-harmonic_ABS}$	☑	☑	☑1ph	
	$U_{1-3_signaling_ \%}$	☑📖	☑📖	☑1ph📖	monitoring of signaling (ripple) voltage of set frequency. % of RMS or % of base
	$U_{1-3_signaling_ABS}$	☑	☑	☑1ph	
	$I_{1-3_harmonic_1-63_ \%}$	☑📖	☑📖	☑1ph📖	% of RMS or % of base
	$I_{1-3_harmonic_1-63_ABS}$	☑	☑	☑1ph	
	$I_{1-3_harmonic_1-63_ \varphi}$	☑	☑	☑1ph	
	<i>Flickers</i>				
P_{i1-3}	☑	☑	☑1ph	Instantaneous flicker sensation measured with 150 samples / sec (original sampling is 1200 smpl/sec)	
P_{st1-3}	☑	☑	☑1ph	10 min statistical evaluation (128 classes of CPF)	
P_{lt1-3}	☑	☑	☑1ph	derived from 12 Pst acc. to EN 61000-4-15	

📖 Further description is available in following subchapters

Table 14: Selection of available measurement quantities

Meas. type	Measurement	3-phase 4-wire	3-phase 3-wire	1-phase	comments
Phase to phase measurements	<i>Voltage</i>				
	U_{pp1-3_RMS}	<input checked="" type="checkbox"/>	<input checked="" type="checkbox"/>		
	U_{ppAVG_RMS}	<input checked="" type="checkbox"/>	<input checked="" type="checkbox"/>		
	$THD-U_{pp1-3}$	<input checked="" type="checkbox"/>	<input checked="" type="checkbox"/>		
	φ_{x-y_RMS}	<input checked="" type="checkbox"/>			Phase-to-phase angle
	$U_{pp1-3_harmonic_1-63_ \%}$	<input checked="" type="checkbox"/>	<input checked="" type="checkbox"/>	<input checked="" type="checkbox"/> 1ph	% of RMS or % of base
	$U_{pp1-3_harmonic_1-63_ABS}$	<input checked="" type="checkbox"/>	<input checked="" type="checkbox"/>	<input checked="" type="checkbox"/> 1ph	
	$U_{pp1-3_harmonic_1-63_ \varphi}$	<input checked="" type="checkbox"/>	<input checked="" type="checkbox"/>	<input checked="" type="checkbox"/> 1ph	
	$U_{underdeviation}$	<input checked="" type="checkbox"/>	<input checked="" type="checkbox"/>	<input checked="" type="checkbox"/> 1ph	<i>U_{under.} and U_{over.} are calculated for phase or phase-to-phase voltages regarding connection mode.</i>
$U_{overdeviation}$	<input checked="" type="checkbox"/>	<input checked="" type="checkbox"/>	<input checked="" type="checkbox"/> 1ph		
Metering	<i>Energy</i>	<input checked="" type="checkbox"/>	<input checked="" type="checkbox"/>	<input checked="" type="checkbox"/>	
	Counter E_{1-4}	<input checked="" type="checkbox"/>	<input checked="" type="checkbox"/>	<input checked="" type="checkbox"/>	<i>each counter can be dedicated to any of four quadrants (P-Q, import-export, L-C). Total energy is a sum of one counter for all tariffs. Tariffs can be fixed, date/time dependent or tariff input dependent</i>
	E_{TOT_1-4}	<input checked="" type="checkbox"/>	<input checked="" type="checkbox"/>	<input checked="" type="checkbox"/>	
	Active tariff	<input checked="" type="checkbox"/>	<input checked="" type="checkbox"/>	<input checked="" type="checkbox"/>	
Auxiliary channel measurements	<i>Aux. line</i>				
	$U_{NEUTRAL-EARTH}$	<input checked="" type="checkbox"/>	<input checked="" type="checkbox"/>	<input checked="" type="checkbox"/>	<i>aux. voltage is dedicated for neutral-earth meas. only</i>
	$I_{NEUTRAL_meas}$	<input checked="" type="checkbox"/>	<input checked="" type="checkbox"/>	<input checked="" type="checkbox"/>	<i>measured neutral current with 4th current input</i>
	$I_{NEUTRAL_calc}$	<input checked="" type="checkbox"/>	<input checked="" type="checkbox"/>	<input checked="" type="checkbox"/>	<i>calculated neutral current</i>
	$I_{NEUTRAL_err}$	<input checked="" type="checkbox"/>	<input checked="" type="checkbox"/>	<input checked="" type="checkbox"/>	<i>error neutral current (difference between measured and calculated)</i>
Maximum demand measurements	<i>Maximum demand</i>				
	$MD_{I_{1-3}}$	<input checked="" type="checkbox"/>	<input checked="" type="checkbox"/>	<input checked="" type="checkbox"/> 1ph	
	$MD_{P_{import}}$	<input checked="" type="checkbox"/>	<input checked="" type="checkbox"/>	<input checked="" type="checkbox"/>	
	$MD_{P_{export}}$	<input checked="" type="checkbox"/>	<input checked="" type="checkbox"/>	<input checked="" type="checkbox"/>	
	$MD_{Q_{ind}}$	<input checked="" type="checkbox"/>	<input checked="" type="checkbox"/>	<input checked="" type="checkbox"/>	
	$MD_{Q_{cap}}$	<input checked="" type="checkbox"/>	<input checked="" type="checkbox"/>	<input checked="" type="checkbox"/>	
	MD_S	<input checked="" type="checkbox"/>	<input checked="" type="checkbox"/>	<input checked="" type="checkbox"/>	

Further description is available in following subchapters

Table 14: Selection of available measurement quantities

Meas. type	Measurement	3-phase 4-wire	3-phase 3-wire	1-phase	comments
Min and max measurements	Min and max				
	$U_{1-3_RMS_MIN}$	<input checked="" type="checkbox"/>	<input checked="" type="checkbox"/>	<input checked="" type="checkbox"/> 1ph	
	$U_{1-3_RMS_MAX}$	<input checked="" type="checkbox"/>	<input checked="" type="checkbox"/>	<input checked="" type="checkbox"/> 1ph	
	$U_{pp1-3_RMS_MIN}$	<input checked="" type="checkbox"/>	<input checked="" type="checkbox"/>	<input checked="" type="checkbox"/>	
	$U_{pp1-3_RMS_MAX}$	<input checked="" type="checkbox"/>	<input checked="" type="checkbox"/>	<input checked="" type="checkbox"/>	
	$I_{1-3_RMS_MIN}$	<input checked="" type="checkbox"/>	<input checked="" type="checkbox"/>	<input checked="" type="checkbox"/> 1ph	
	$I_{1-3_RMS_MAX}$	<input checked="" type="checkbox"/>	<input checked="" type="checkbox"/>	<input checked="" type="checkbox"/> 1ph	
	$P_{1-3_RMS_MIN}$	<input checked="" type="checkbox"/>	<input checked="" type="checkbox"/>	<input checked="" type="checkbox"/> 1ph	
	$P_{1-3_RMS_MAX}$	<input checked="" type="checkbox"/>	<input checked="" type="checkbox"/>	<input checked="" type="checkbox"/> 1ph	
	$P_{TOT_RMS_MIN}$	<input checked="" type="checkbox"/>	<input checked="" type="checkbox"/>	<input checked="" type="checkbox"/> 1ph	
	$P_{TOT_RMS_MAX}$	<input checked="" type="checkbox"/>	<input checked="" type="checkbox"/>	<input checked="" type="checkbox"/> 1ph	
	$S_{1-3_RMS_MIN}$	<input checked="" type="checkbox"/>	<input checked="" type="checkbox"/>	<input checked="" type="checkbox"/> 1ph	
	$S_{1-3_RMS_MAX}$	<input checked="" type="checkbox"/>	<input checked="" type="checkbox"/>	<input checked="" type="checkbox"/> 1ph	
	$S_{TOT_RMS_MIN}$	<input checked="" type="checkbox"/>	<input checked="" type="checkbox"/>	<input checked="" type="checkbox"/> 1ph	
	$S_{TOT_RMS_MAX}$	<input checked="" type="checkbox"/>	<input checked="" type="checkbox"/>	<input checked="" type="checkbox"/> 1ph	
	Other measurements	Miscellaneous			
$freq_{MEAN}$		<input checked="" type="checkbox"/>	<input checked="" type="checkbox"/>	<input checked="" type="checkbox"/>	
Internal temp.		<input checked="" type="checkbox"/>	<input checked="" type="checkbox"/>	<input checked="" type="checkbox"/>	
Date, Time		<input checked="" type="checkbox"/>	<input checked="" type="checkbox"/>	<input checked="" type="checkbox"/>	
Last Sync. time		<input checked="" type="checkbox"/>	<input checked="" type="checkbox"/>	<input checked="" type="checkbox"/>	UTC
GPS Time		<input checked="" type="checkbox"/>	<input checked="" type="checkbox"/>	<input checked="" type="checkbox"/>	If GPS receiver is connected to dedicated RTC time synchronization input
GPS Longitude		<input checked="" type="checkbox"/>	<input checked="" type="checkbox"/>	<input checked="" type="checkbox"/>	
GPS Latitude		<input checked="" type="checkbox"/>	<input checked="" type="checkbox"/>	<input checked="" type="checkbox"/>	
GPS Altitude		<input checked="" type="checkbox"/>	<input checked="" type="checkbox"/>	<input checked="" type="checkbox"/>	

Further description is available in following subchapters

Table 14: Selection of available measurement quantities

Explanation of basic concepts

Sample frequency

A device measures all primary quantities with a constant sampling rate of 32 kHz (625 s/per at 50 Hz).

Average interval

Operation of **MAVOLOG PRO Quality Analyser** depends on several Average intervals, which should all be well understood and set to a proper value.

Average interval for measurements and display

Due to readability of measurements from LCD and communication, an Average interval can be selected from a range of predefined values (from 0.1s to 5 s). The Average interval (see chapter *Average interval on page 46*) defines refresh rate of displayed measurements.

Alarms response time is influenced by general average interval if their response time setting is set to "Normal response". If it is set to "Fast response" alarms depend on a single period measurement.

This average interval has no influence on PQ measurements.

Average interval for min. max. values

Min. and max. values often require special averaging period, which enables or disables detection of short measuring spikes. With this setting is possible to set averaging from 1 period to 256 periods.

Average (storage) interval for recorders

This storage interval defines a period for writing data into internal memory. It can be set from 1 min to 60 min. At the end of every interval different types of measured data can be stored into recorder (see *General purpose recorder settings on page 88*).

Average (aggregation) interval for PQ parameters

Standard IEC61000-4-30 defines different aggregation intervals and procedures for aggregation of measured PQ parameters.

For each PQ parameter it is possible to set required aggregation interval. Standard aggregation intervals are:

- 10 periods (12 for 60 Hz system)
- 150 periods (180 for 60 Hz system)
- 10 sec
- 10 min (also basic time synchronisation tick interval)
- 2 h

It is also possible to set other aggregation intervals according to requirements. **MAVOLOG PRO Quality Analyser** supports additional aggregation intervals; 30 sec, 1 min, 15 min, 1 h.

Calculation and display of measurements

This chapter deals with capture, calculation and display of all supported quantities of measurement. Only the most important equations are described; however, all of them are shown in a chapter *Equations* on page 176 with additional descriptions and explanations.



PLEASE NOTE

Calculation and display of measurements depend on the connection used. For more detailed information see chapter *Survey of supported measurements on page 109*.

Keyboard and display presentation

For entry and quitting measurements display menu, the **OK** key is used. Direction keys ($\leftarrow \rightarrow \uparrow \downarrow$) are used for passing between displays as show in example below.

Example for 4u connection mode:

Main menu \Rightarrow Measurements \Rightarrow Present values \Rightarrow Voltage

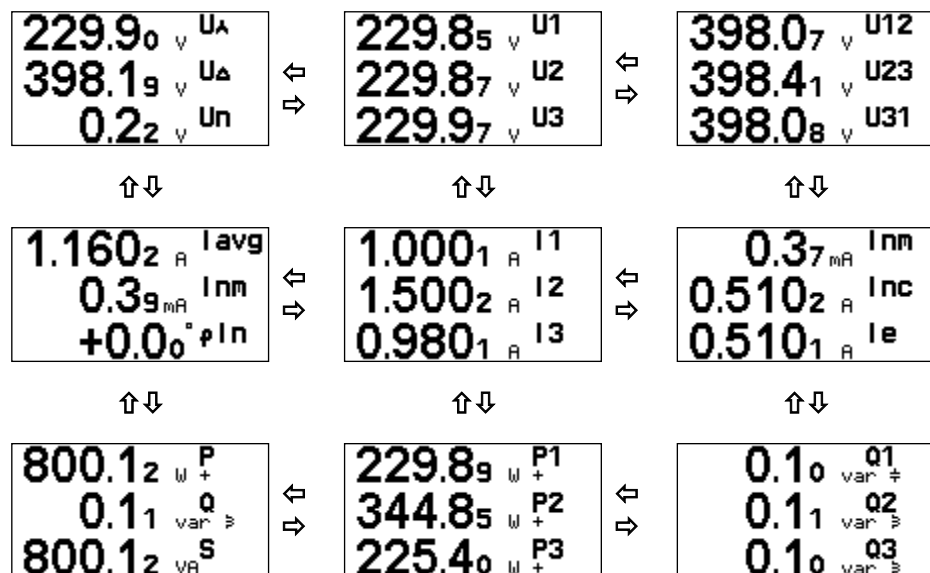

Present values

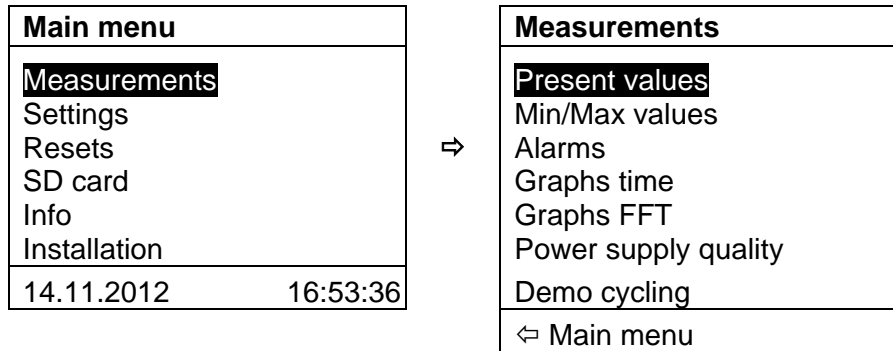

PLEASE NOTE

Display of present values depends on connection mode. Therefore display organisation slightly differs from one connection mode to another.

Voltage

The device measures real effective (rms) value of all phase voltages (U1, U2, U3), phase-to-phase voltages (U12, U23, U31) and neutral to earth voltage (Un), connected to it. Average phase voltage (Uf) and average phase-to-phase voltage (Ua) are calculated from measured phase voltages (U1, U2, U3). Voltage unbalance is calculated from phase-to-phase voltages (U12, U23, U31).

$$U_f = \sqrt{\frac{\sum_{n=1}^N u_n^2}{N}} \quad U_{xy} = \sqrt{\frac{\sum_{n=1}^N (u_{xn} - u_{yn})^2}{N}}$$

All voltage measurements are available on communication and standard or customized displays on LCD.

Device warns if input signal is too large. In this case signal representation is not correct. Indicator ⚠ is shown above parameter unit:

999.6 ⚠ U1
 V
 1001.0 ⚠ U2
 V
 1000.9 ⚠ U3
 V

Main menu ⇒ Measurements ⇒ Present values ⇒ Voltage

Current  

Device measures real effective (rms) value of phase currents and neutral measured current (I_{nm}), connected to current inputs. Neutral calculated current (I_{nc}), Neutral error current ($I_e = |I_{nm} - I_{nc}|$), phase angle between Neutral voltage and Neutral Current (φ_{In}), Average current (I_a) and a sum of all phase currents (I_t) are calculated from phase currents.

$$I_{RMS} = \sqrt{\frac{\sum_{n=1}^N i_n^2}{N}}$$

All current measurements are available on communication, standard and customized displays on LCD.

 **Main menu** ⇒ **Measurements** ⇒ **Present values** ⇒ **Current**

Active, reactive and apparent power  

Active power is calculated from instantaneous phase voltages and currents. All measurements are seen on communication or are displayed on LCD. For more detailed information about calculation see chapter *Equations on page 176*.

There are two different methods of calculating reactive power. See chapter *Reactive power and energy calculation on page 53*.

Device warns if input signal is too large. In this case signal representation is not correct. Indicator $\hat{\wedge}$ is shown above parameter unit:

999.6 $\hat{\wedge}$ ₅ V U1
4.998 $\hat{\wedge}$ ₉ A I1
4327.7 $\hat{\wedge}$ _W + P1

 **Main menu** ⇒ **Measurements** ⇒ **Present values** ⇒ **Power**

Power factor and power angle  

Power angle is calculated as quotient of active and apparent power for each phase separately ($\cos\phi_1, \cos\phi_2, \cos\phi_3$) and total power angle ($\cos\phi_t$). A symbol for a coil represents inductive load and a symbol for a capacitor represents capacitive load. For correct display of PF via analogue output and application of the alarm, ePF (extended power factor) is applied. It illustrates power factor with one value as described in the table below. For a display on LCD both of them have equal display function: between -1 and +1 with the icon for inductive or capacitive load.

Table 15: Presentation of extended PF (ePF)

Load	C	→		←	L
Angle [°]	-180	-90	0	+90	+180 (179.99)
PF	-1	0	1	0	-1
ePF	-1	0	1	2	3

Example of analogue output for PF and ePF:

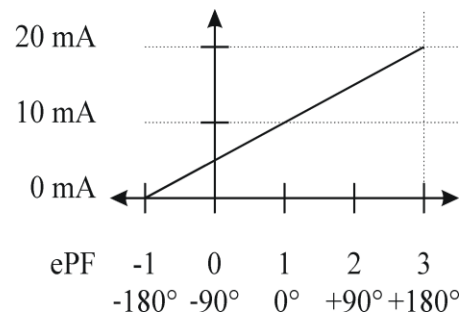
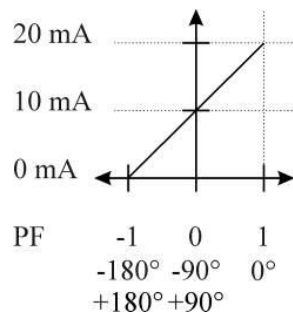

Power angle represents angle between first (base) voltage harmonic and first (base) current harmonic for each individual phase. Total power angle is calculated from total active and reactive power (see equation for Total power angle, chapter *Equations on page 176*). A positive sign shows inductive load, and a negative sign shows capacitive load.

 **Main menu** ⇒ **Measurements** ⇒ **Present values** ⇒ **PF & Power angle**

Frequency

Network frequency is calculated from time periods of measured voltage. Device uses synchronisation method, which is highly immune to harmonic disturbances.

Device always synchronises to a phase voltage $U1$. If signal on that phase is too low it (re)synchronises to next phase. If all phase voltages are low (e.g. short circuit) device synchronises to phase currents. If there is no signal present on any voltage or current channels, device shows frequency 0 Hz.

Additionally frequency with 10-second averaging interval is displayed.

 **Main menu** ⇒ **Measurements** ⇒ **Present values** ⇒ **Frequency**

Energy - counters

Three ways of Energy - counters display are available:

- by individual counter,
- by tariffs for each counter separately and
- energy cost by counter

At a display of measured counter by tariffs, the sum in the upper line depends on the tariffs set in the device.

There are two different methods of calculating reactive energy. See chapter *Reactive power and energy calculation on page 53*.

Additional information, how to set and define a counter quantity is explained in chapter *ENERGY – counters on page 67*.

 **Main menu** ⇒ **Measurements** ⇒ **Present values** ⇒ **Energy**

MD values

MD values and time stamp of occurrence are shown for:

- Three phase currents
- Active powers (import and export)
- Reactive power (ind. and cap.)
- Apparent power

 **Main menu** ⇒ **Measurements** ⇒ **Present values** ⇒ **MD values**

Dynamic demands are continuously calculated according to set time constants and other parameters.

Reset demands are max. values of Dynamic demands since last reset.

THD – Total harmonic distortion  

THD is calculated for phase currents, phase voltages and phase-to-phase voltages and is expressed as percent of high harmonic components regarding to fundamental harmonic (see chapter *Calculation of harmonics on page 53*).

Device uses measuring technique of real effective (rms) value that assures exact measurements with the presence of high harmonics up to 63rd harmonic.

 **Main menu** ⇒ **Measurements** ⇒ **Present values** ⇒ **THD**

Flickers  

Flickers are one of most important PQ parameters directly (through light flickering) influencing human feeling.

Flickers are measured in statistically evaluated according to relevant standard IEC 61000-4-15.

For basic flicker measurements on all three voltage phases 1200 readings per second is used. Instantaneous flicker sensation decimates this sampling rate 8 times (150 instantaneous flicker calculations per second) and uses approx 3s averaging time.

With further statistical evaluation short term and long term flickers are calculated.

Pi_{1-3} represents instantaneous flicker and is averaged and refreshed every 3 sec. Pi is averaged from 500 instantaneous flicker calculations.

Pim_{1-3} represents max. value of instantaneous flicker Pi within 3 sec flicker averaging interval and is refreshed every 3 sec. This value is displayed only on display. It is not available on communication.

Pst_{1-3} represents 10 min statistical evaluation of instantaneous flicker and is refresh every round 10 minutes (x:00, x:10, x:20...)

Plt_{1-3} represents 2 h statistical evaluation of short-time flicker Pst and is refreshed every even 2 hours (0:00, 2:00, 4:00...)

Until the flicker value is calculated the symbol – is displayed.

 **Main menu** ⇒ **Measurements** ⇒ **Present values** ⇒ **Flickers**

Customized screens  

Here 4 different customised screens are shown. First three screens show 3 different user defined values. Fourth screen displays 5 different values as a combination of 3 values of first screen and first 2 values of second screen.

See chapter *Settings of customized screens on page 63.*

 **Main menu** ⇒ **Measurements** ⇒ **Present values** ⇒ **Custom**

Overview 

It combines several measurements on each display as the following screens are displayed:



Screen 1:

Current phase measurements			Current phase measurements		
U _A	Average voltage U [~]	V	P	Total active power P _t	W
1	Phase voltage U ₁	V	P1	Active power P ₁	W
2	Phase voltage U ₂	V	P2	Active power P ₂	W
3	Phase voltage U ₃	V	P3	Active power P ₃	W
I _A	Average current I [~]	A	Q	Total reactive power Q _t	var
1	Current I ₁	A	Q1	Reactive power Q ₁	var
2	Current I ₂	A	Q2	Reactive power Q ₁	var
3	Current I ₃	A	Q3	Reactive power Q ₁	var

Screen 2:

Current phase-to-phase measurements			Current phase-to-phase measurements		
U _Δ	Average phase-to-phase U [~]	V	Frequency f		Hz
12	Phase-to-phase voltage U ₁₂	V	φ	Power angle φ ₁	°
23	Phase-to-phase voltage U ₂₃	V	φ	Power angle φ ₂	°
31	Phase-to-phase voltage U ₃₁	V	φ	Power angle φ ₃	°
PF	Total power factor		φ	Average phase-to-phase angle φ [~]	°
PF1	Power factor PF ₁		φ	Power angle φ ₁₂	°
PF2	Power factor PF ₂		φ	Power angle φ ₂₃	°
PF3	Power factor PF ₃		φ	Power angle φ ₁	°

Screen 3:

Dynamic MD values			Maximal MD values		
P+	MD active power P (positive)	W		MD active power P (positive)	W
P-	MD active power P (negative)	W	φ	MD active power P (negative)	W
Q	MD reactive power Q-L	var	φ	MD reactive power Q-L	var
					
Q	MD reactive power Q-C	var	φ	MD reactive power Q-C	var
					
S	MD apparent power S	VA	φ	MD apparent power S	VA
I1	MD current I1	A	φ	MD current I1	A
I2	MD current I2	A	φ	MD current I2	A
I3	MD current I3	A	φ	MD current I3	A

Example for **MAVOLOG PRO** at connection 4u:

 **Main menu** ⇒ **Measurements** ⇒ **Present values** ⇒ **Overview**

U _A 229.89 V P +800.11 U ₁ 229.85 V P1 +229.88 U ₂ 229.86 V P2 +344.84 U ₃ 229.97 V P3 +225.39 I _A 1.1602 A Q +0.11 I ₁ 1.0001 A Q1 -0.10 I ₂ 1.5002 A Q2 +0.11 I ₃ 0.9801 A Q3 +0.10	⇔	U _Δ 398.19 V 52.999 Hz I ₁₂ 398.07 V φ -119.98 I ₂₃ 398.40 V φ -120.11 I ₃₁ 398.08 V φ -119.94 PF +1.000L φ +0.00 PF1 +1.000C φ -0.03 PF2 +1.000L φ +0.01 PF3 +1.000L φ +0.02	⇔	P+=793.76 39.995kW P-= 0.000 39.995kW Q+= 0.343 39.995kvar Q-= 0.000 39.995kvar S =795.14 39.995kVA I1=0.9927 19.998 A I2=1.4893 19.998 A I3=0.9729 19.998 A
--	---	--	---	---

Min/Max values

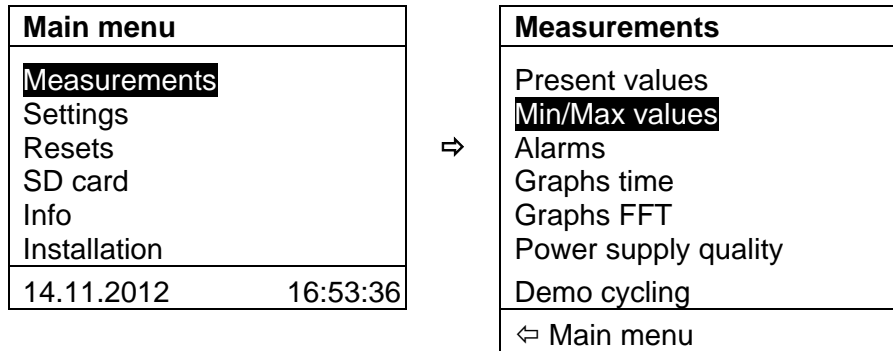

All Min/Max values are displayed similar as Present values.

Average interval for min. max. values

Min. and max. values often require special averaging period, which enables or disables detection of short measuring spikes. With this setting is possible to set averaging from 1 period to 256 periods.

Display of min. and max. values

Present values are displayed with larger font in the middle of the screen, while minimal and maximal values are displayed smaller above and below the present values.

Example of Min/Max screens 

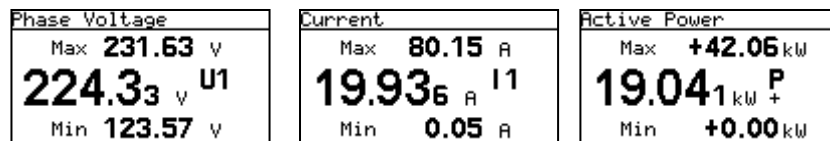

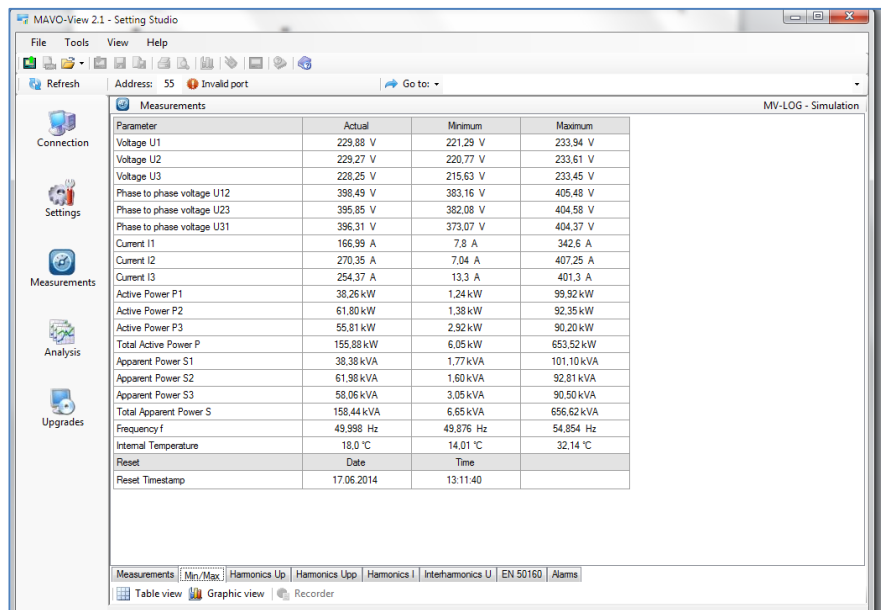

Figure 30: Tabular presentation of min. max. values

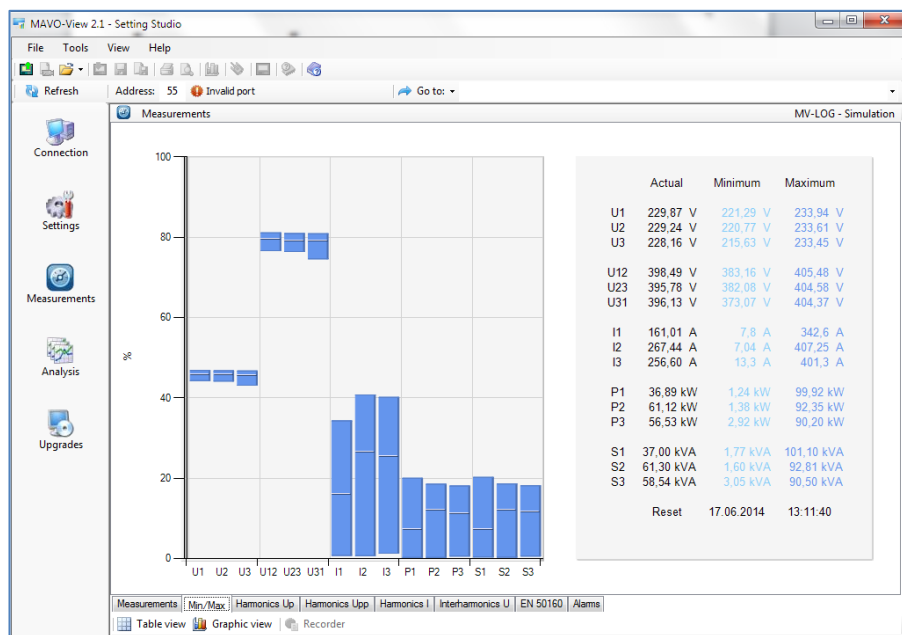
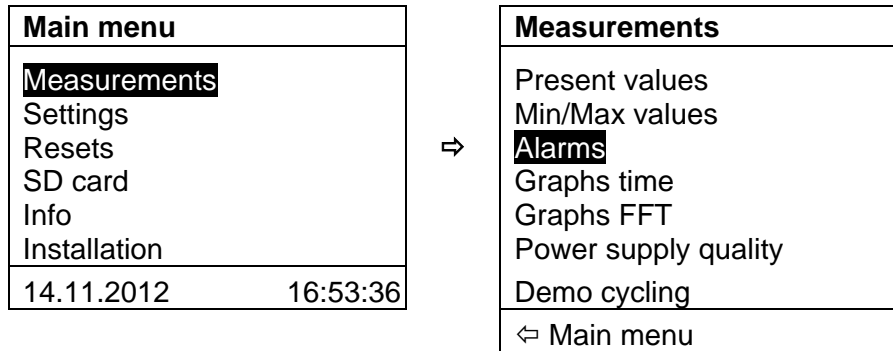

Figure 31: Graphical presentation of min. max. values

In graphical presentation of min. and max. values relative values are depicted. Base value for relative representation is defined in general settings/Connection mode/used voltage, current range.

For phase voltages and for phase-to-phase voltages the same value is used.

Alarms



Alarms are important feature for notifying exceeded user predefined values. Not only for visualisation and recording certain events with exact time stamp. Alarms can be connected to digital/alarm outputs to trigger different processes (switch closures, line breaking, motors start or stop...).

It is also very convenient to monitor alarms history. This is enabled on display and even better on communication by using monitoring and setting software MAVO-View.

Alarm menu on display enables surveying state of ongoing and past alarms.

In the alarm menu, groups of alarms with states of individual alarms are displayed. Also connected alarm outputs are displayed in the bottom line. If displayed alarm output is highlighted means it is active (relay closed). For each active alarm a number of alarms is written in a certain group at a certain place: Group 1: 1 ■ ■ ■ 45 ■ ■ ■ 8. Dot stands for alarm not active.

In example below there was 1 alarm, which happened under condition defined in Group1/Alarm1 (middle picture). Condition for that alarm was $U1 > 250.00 V$ (right picture). Alarm activated Relay output 2 (middle picture, highlighted Out2).

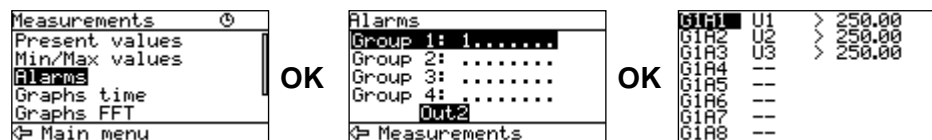

Survey of alarms

In a detailed survey alarms are collected in groups. A number of a group and alarm is stated in the first column, a measurement designation in the second, and a condition for alarm in the third one. Active alarm is marked.

 Main menu ⇒ Measurements ⇒ Alarms

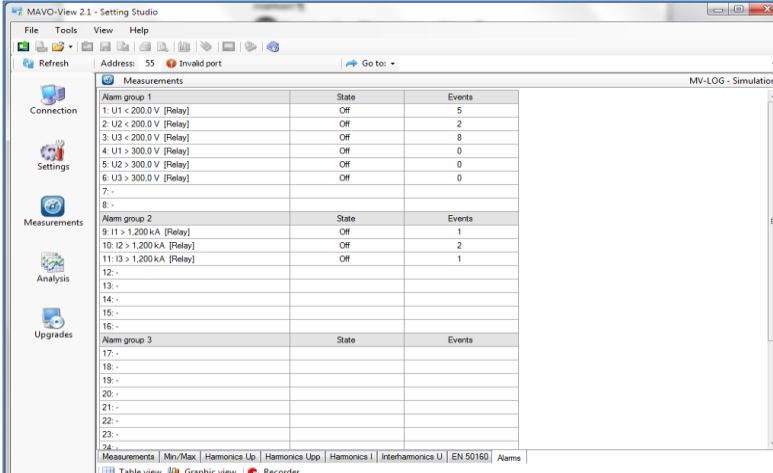

Alarm group	State	Events
Alarm group 1		
1: U1 < 200.0 V [Relay]	Off	5
2: U2 < 200.0 V [Relay]	Off	2
3: U3 < 200.0 V [Relay]	Off	8
4: U1 > 300.0 V [Relay]	Off	0
5: U2 > 300.0 V [Relay]	Off	0
6: U3 > 300.0 V [Relay]	Off	0
7: -		
8: -		
Alarm group 2		
9: I1 > 1,200 kA [Relay]	Off	1
10: I2 > 1,200 kA [Relay]	Off	2
11: I3 > 1,200 kA [Relay]	Off	1
12: -		
13: -		
14: -		
15: -		
16: -		
Alarm group 3		
17: -		
18: -		
19: -		
20: -		
21: -		
22: -		
23: -		
24: -		

Figure 32: Tabular presentation of alarms

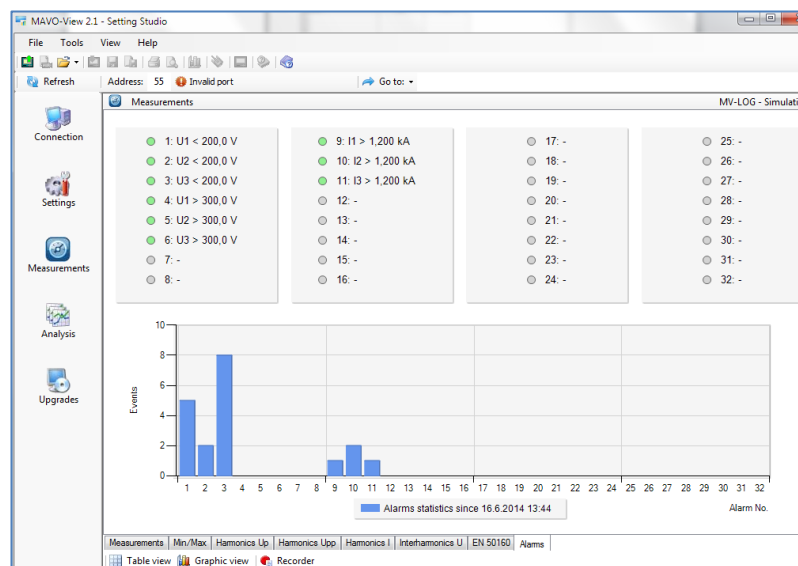

Figure 33: Graphical presentation of alarms

In MAVO-View software all alarms are presented in tabular and graphical form as shown in figures above. For each alarm is shown:

- Group association
- Group Alarm conditions
- Momentary alarm state

Number of alarm events since last reset

Harmonic analysis

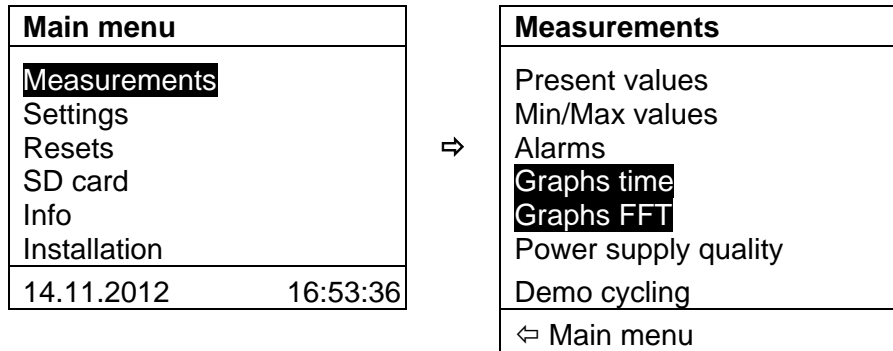

Harmonic analysis is an important part of PQ monitoring. Frequency converters, inverters, electronic motor drives, LED, halogen and other modern lamps. All this cause harmonic distortion of supply voltage and can influence other sensitive equipment to malfunction or even break.

In particular vulnerable are distribution level compensation devices whose capacitor banks act like a drain for higher harmonics amplify their influence. Higher harmonic currents flowing through capacitors can cause overheating and by that shortening their lifetime or even explosions.

Monitoring harmonic distortion is therefore important not only to prevent malfunction of household equipment and to prolong operation of motors but also to prevent serious damage to distribution equipment and to people working close to compensation devices.

Due to importance of harmonic analysis special standard IEC 61000-4-7 defines methods for measurement and calculation of harmonic parameters.

MAVOLOG PRO Quality Analyser measures harmonics up to 63rd and evaluates following harmonic parameters:

- Phase Voltage harmonic signals
- THD U_{P-N}
- Phase-to-phase Voltage harmonic signals
- THD U_{P-P}
- Current harmonic signals
- THD I
- Interharmonics (10 user defined interharmonic values)
- Signalling voltage (monitoring ripple control signal)



PLEASE NOTE

Interharmonics are available only on communication.

All of the listed harmonic parameters can be monitored online, stored in internal memory (not all at a time) and compared against alarm condition threshold limit.

The latter is in combination with alarm relay output suitable for notification and/or automatic disconnection of compensation devices, when too much harmonics could threaten capacitors.

Display of harmonic parameters

Harmonic parameters can be displayed on devices LCD in graphical form and as a data.

Representation of individual harmonics consists of:

- Absolute value
- Relative value
- Phase angle between base and observed harmonic



PLEASE NOTE

Relative value can be calculated as a percentage of base unit or as a percentage of RMS value. Setting for choice of this relative factor is under General settings (see *Harmonic calculation setting on page 53*)

Main menu \Rightarrow Measurements \Rightarrow Graphs time / Graphs FFT

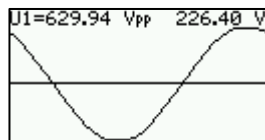

Display of a Phase Voltage in time space diagram. Displayed are also peak value of monitored phase voltage and its RMS value. Similar display is also for phase-to-phase voltages.

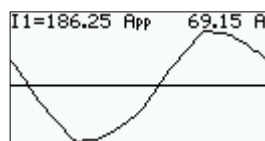

Display of a Current in time space diagram. Displayed are also peak value of monitored current and its RMS value

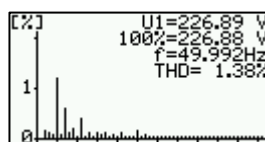

Display of a Phase Voltage in frequency space diagram. Displayed are also RMS value, unit value (100%), system frequency and THD value. Similar display is also for phase-to-phase voltages.

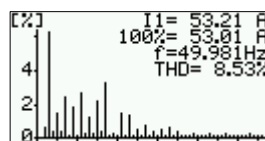

Display of a Current in frequency space diagram. Displayed are also RMS value, unit value (100%), system frequency and THD value.

More information about harmonic parameters, especially individual harmonic values, can be obtained when device is connected to communication and monitoring and setting software MAVO-View is used.

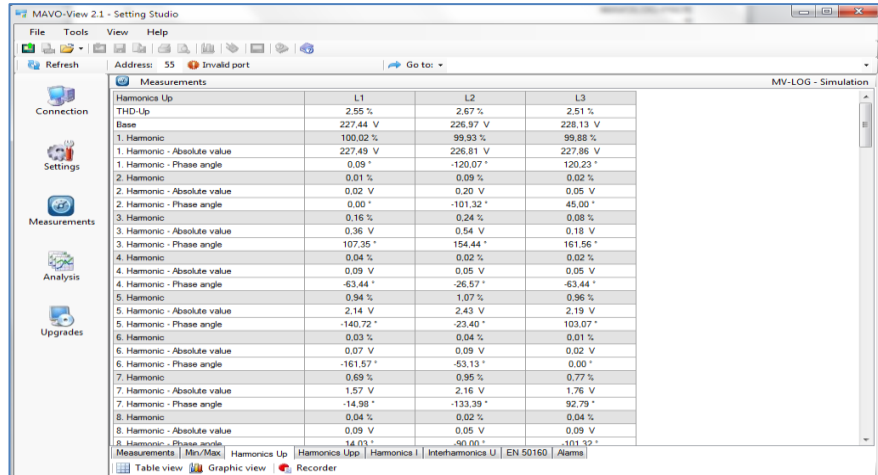

Figure 34: Tabular presentation of phase voltage harmonic components

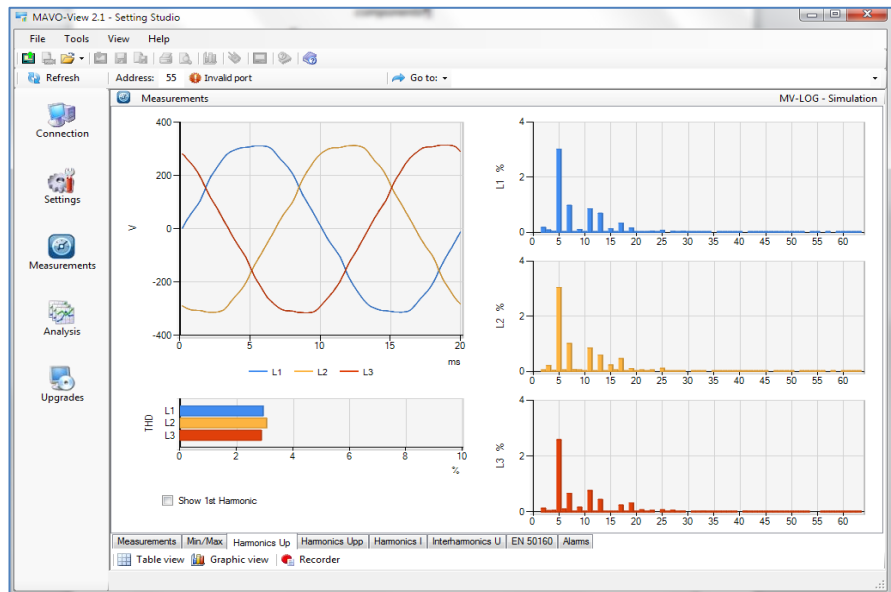

Figure 35: Graphical presentation of phase voltage harmonic components



PLEASE NOTE

According to standard IEC 61000-4-7 that defines methods for calculation of harmonic parameters, harmonic values and interharmonic values do not represent signal magnitude at exact harmonic frequency but weighted sum of centered (harmonic) values and its sidebands. More information can be found in mentioned standard.

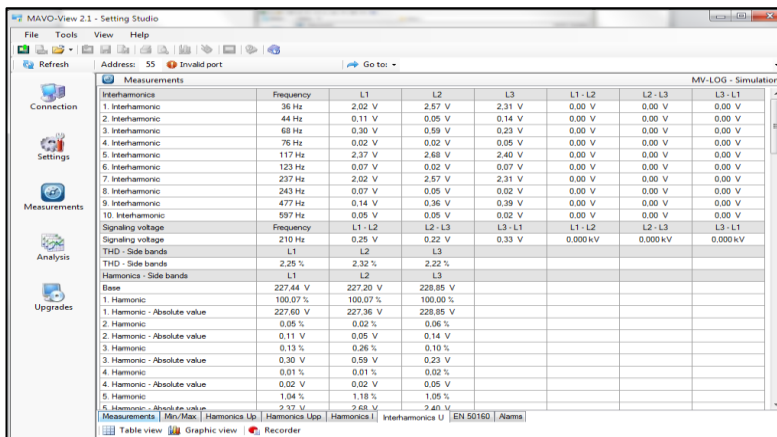
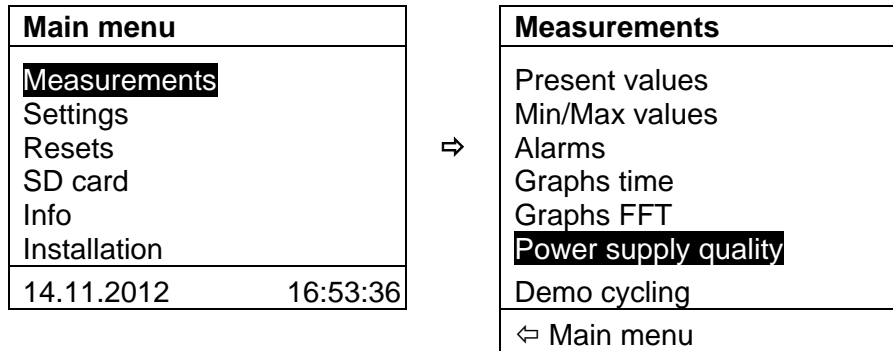

Figure 36: Tabular presentation of 10 phase voltage interharmonic components



Figure 37: Graphical presentation of phase voltage interharmonic component

PQ Analysis



PQ analysis is a core functionality of **MAVOLOG PRO Quality Analyser**. PQ (Power Quality) is a very common and well understood expression. However it is not exactly in accordance with its actual meaning.

PQ analysis actually deals with Quality of Supply Voltage. Supply Voltage is a quantity for quality of which utility companies are responsible. It influences behaviour of connected apparatus and devices.

Current and power on the other hand are consequence of different loads and hence responsibility of consumers. With proper filtering load influence can be restricted within consumer internal network or at most within single feeder while poor supply voltage quality influences much wider area.

Therefore indices of supply voltage (alias PQ) are limited to anomalies connected only to supply voltage:

Table 16: Power Quality indices as defined by EN 50160

Phenomena	PQ Parameters
Frequency variations	Frequency distortion
Voltage variations	Voltage fluctuation Voltage unbalance
Voltage changes	Rapid voltage changes Flicker
Voltage events	Voltage dips Voltage interruptions Voltage swells
Harmonics & THD	THD Harmonics Interharmonics Signalling voltage

For evaluation of voltage quality, device can store main characteristics in the internal memory. The reports are made on the basis of stored data. Data of the last 300 weeks and up to 170,000 variations of the measured quantities from the standard values are stored in the report, which enables detection of anomalies in the network.

MAVO-View software offers a complete survey of reports with a detailed survey of individual measured quantities and anomalies. A survey of compliance of individual measured quantities in previous and current monitored periods is possible.

Online monitoring

When all PQ parameters are set and analysis is enabled (information about settings for PQ analysis can be found in a chapter *Conformity of PQ according to EN 50160* on page 93) PQ starts with defined date and starts issuing weekly reports (if monitoring period setting is set to one week).

MAVO-View software enables monitoring state of current period and of previous monitoring period. Both periods can be overviewed on a devices display as well.



Main menu ⇒ Measurements ⇒ Power supply quality ⇒ Current period/Previous period

Example of PQ report for current period generated on devices display. More detailed information about PQ is available on communication.

<pre>Actual period Start : 05.01.2013 End : 11.01.2013 Status : Not compl. Compila.: X Report: 2/2013</pre>	<p>Basic information about current monitoring period. Period is not completed and currently not in compliance with EN 50160</p>
<pre>Actual period Frequency 1 : ✓ Frequency 2 : X Unbalance : ✓ Voltage 1 : ✓ Voltage 2 : ✓ Report: 2/2013</pre>	<p>Display of current status of PQ parameters. Some are currently not in compliance with EN 50160</p>
<pre>Actual period THD : ✓ Harmonics : ✓ Short flickers : ✓ Long flickers : X Rapid V. chg. : ✓ Report: 2/2013</pre>	<p>Display of current status of PQ parameters. Some are currently not in compliance with EN 50160</p>
<pre>Actual period Overvoltages : ✓ Dips : ✓ Short inter. : ✓ Long inter. : ✓ Signalling v.: ✓ Report: 2/2013</pre>	<p>Display of current status of PQ parameters. Some are currently not in compliance with EN 50160</p>

Online monitoring PQ parameters and over viewing reports is easier with MAVO-View.

Aktuelle Überwachungsperiode	Startdatum	Enddatum	Status	Konformität	Standard	
Bericht: 25/2014	12.06.2014	19.06.2014	Unvollständig	OK	EN 50160	
Parameter	L1 (System)	L2	L3	Mehrphasig	Konformität	Geforderte Qualität
Frequenzabweichung 1	99,84 %				OK	99,5 % / Woche
Frequenzabweichung 2	100,00 %				OK	100 % / Woche
Spannungsänderungen 1	98,24 %	100,00 %	97,86 %		OK	95 % / Woche
Spannungsänderungen 2	100,00 %	100,00 %	100,00 %		OK	100 % / Woche
Spannungssymmetrie	99,62 %				OK	95 % / Woche
Schnelle Spannungsänder.	1	2	1	1	OK	20 / Woche
Langzeit-Flicker Pst	99,84 %	95,77 %	96,39 %		OK	95 % / Woche
Spannungseinbrüche	2 / 19	1 / 14	3 / 18	2 / 19	OK	50 / Jahr
Spannungsüberhöhungen	0 / 8	0 / 1	0 / 2	0 / 8	OK	50 / Jahr
Kurze Unterbrechungen	1 / 1	1 / 2	1 / 2	1 / 1	OK	100 / Jahr
Länge Unterbrechungen	1 / 1	1 / 1	1 / 1	1 / 1	OK	10 / Jahr
THD's	99,57 %	98,69 %	98,44 %		OK	95 % / Woche
Hammonische	99,88 %	99,43 %	99,61 %		OK	95 % / Woche
Spannungsspannung	100,00 % / 100,00 %	100,00 % / 100,00 %	100,00 % / 100,00 %		OK	99 % / Tag
EN 61000-4-31	L1 (System)	L2	L3			
Kurzzeit-Flicker Pst	98,55 %	95,46 %	96,12 %			
Vorige Überwachungsperiode	Startdatum	Enddatum	Status	Konformität	Standard	
Bericht: 24/2014	05.06.2014	11.06.2014	Vollständig	Verfehlt	EN 50160	
Parameter	L1 (System)	L2	L3	Mehrphasig	Konformität	Geforderte Qualität
Frequenzabweichung 1	99,91 %				OK	99,5 % / Woche
Frequenzabweichung 2	100,00 %				OK	100 % / Woche
Spannungsänderungen 1	99,55 %	97,33 %	98,73 %		OK	95 % / Woche
Spannungsänderungen 2	100,00 %	100,00 %	100,00 %		OK	100 % / Woche
Spannungssymmetrie	95,91 %				OK	95 % / Woche
Messungen	Min/Max	Hammonische Up	Hammonische Up	Hammonische I	Zwischenhammonische U	EN 50160
Alarmer						

Figure 38: Tabular presentation of PQ parameters and overall compliance status for current and previous monitoring period

For all parameters basic information is shown:

Momentary quality

Momentary quality is for some parameters expressed as a percentage of time, when parameters were inside limit lines and for others (events) is expressed as a number of events within monitored period.

Momentary quality is for some parameters measured in all three phases and for some only in a single phase (frequency). Events can also occur as multiphase events (more about multiphase events is described in following chapters)

Events are according to EN 50160 evaluated on a yearly basis.

Momentary quality information is therefore combined from two numbers (x / y) as shown in a figure above, where:

- x...number of events in monitored period
- y...total number of events in current year

Required quality

Required quality is the limit for compliance with standard EN 50160 and is directly compared with the momentary quality (on the basis of historic values from the device memory). The result of the comparison is the momentary status of compliance.

More information about required quality limits can be found in standard EN 50160.



PLEASE NOTE

To make the complete quality report the aux. power supply for the device should not be interrupted during the whole period for which the report is requested. If firmware is updated or power supply is interrupted within a monitoring period, quality report is incomplete – Status: Not complete.

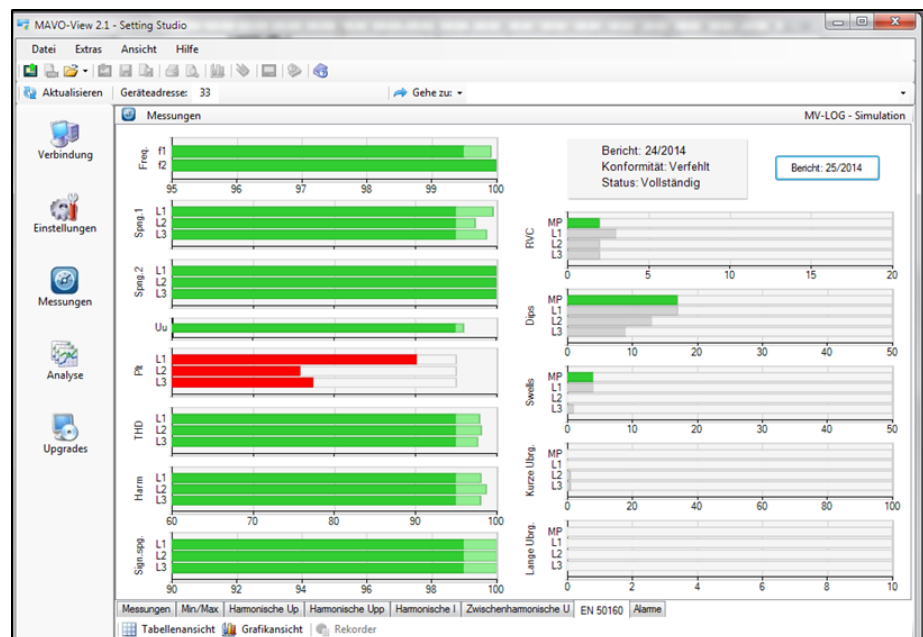

Figure 39: Graphical presentation of PQ parameters and overall compliance are available only for momentary monitoring period

- Darker green colour marks required quality
- Light green colour marks momentary quality
- Red colour marks incompliance with standard EN 50160
- Grey colour at events marks number of events
- MP at events marks multiphase events

PQ records

Even more detailed description about PQ can be obtained by accessing PQ reports with details about anomalies in internal memory.

Structure and operation of internal memory and instructions on how to access data in internal memory is described in chapters *Device management* on page 39 and *Internal memory* on page 88.

After memory has been read information about downloaded data is shown.

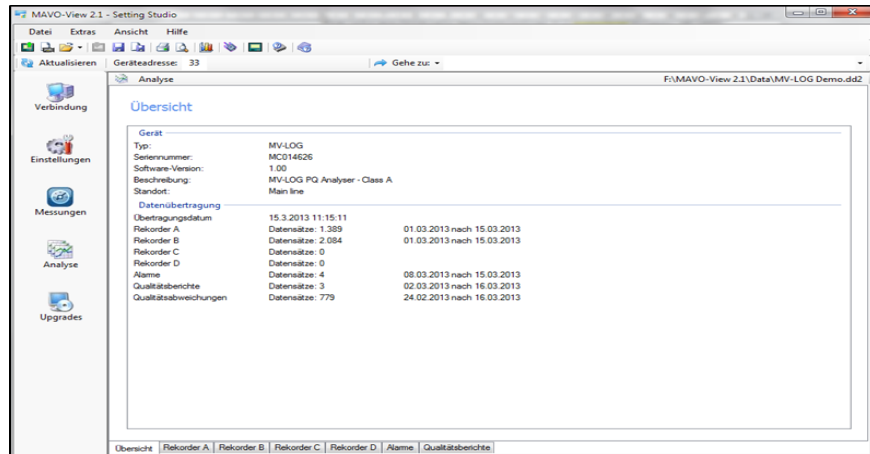

Figure 40: Information about downloaded data with tabs for different memory partitions

All information about PQ is stored in *Quality reports* tab.

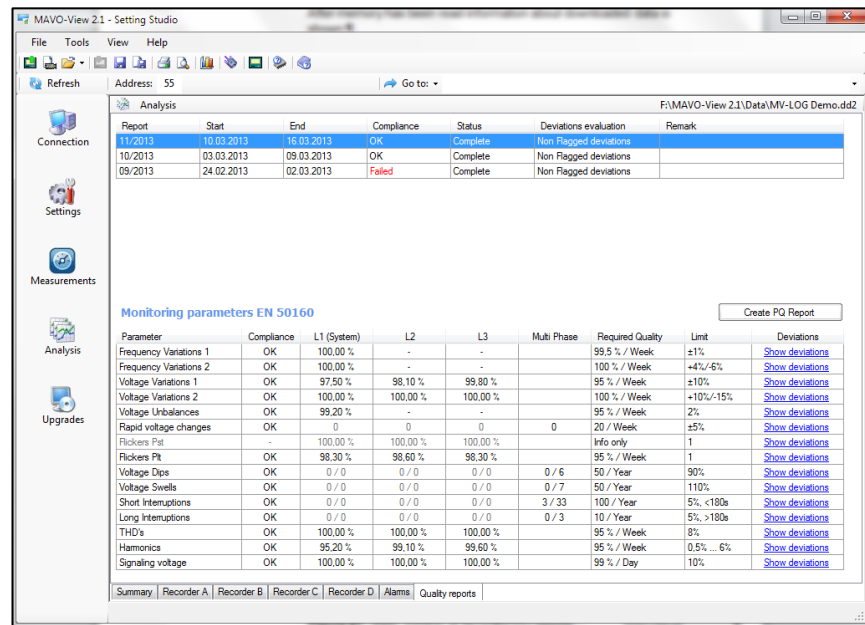

Figure 41: Main window of recorded PQ reports

Main window is divided into two parts. Upper part holds information about recorded periodic PQ reports and lower part holds detailed information about each of upper reports.

For each of monitored parameters it is possible to display anomaly report. This represents a complete list of accurately time stamped measurements that were outside PQ limit lines.

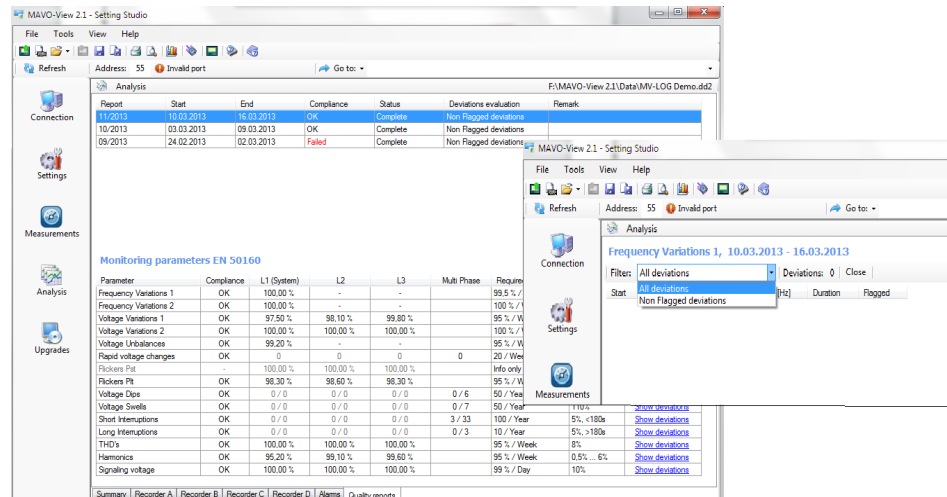

Figure 42: By clicking on “Show details” for each PQ parameter MAVO-View displays time-stamped measurements (events), which were outside limit lines

Flagged data evaluation

Flagged data represent data (recorded events) that has been flagged (marked) according to flagging concept IEC 61000-4-30.

Flagged data are power quality records, which has been influenced by one or more voltage events (interruptions, dips, swells).

The purpose of flagging data is to mark recorded parameters when certain disturbances might influenced measurements and caused corrupted data. For example, voltage dip can also trigger occurrence of flicker, interharmonics... In this case all parameters which were recorded at a time of voltage events are marked (flagged).

PQ report will omit or include flagged data according to appropriate setting (see chapter *Flagged events setting on page 95*).



PLEASE NOTE

Regardless of this setting, readings will be always stored in recorder and available for analysis. Flagging only influences PQ reports as a whole.

In evaluation of PQ parameter details it is possible to show

- All events
- Non-flagged events

as depicted in a figure below.

Start	End	Average [%]	Average [Hz]	Duration	Flagged
24.02.2013 01:16:10	24.02.2013 01:16:20	97.93	48.97	00:00:10	No
24.02.2013 01:45:50	24.02.2013 01:46:00	98.20	49.10	00:00:10	No
24.02.2013 02:10:40	24.02.2013 02:10:50	98.81	49.41	00:00:10	No
24.02.2013 02:28:20	24.02.2013 02:28:30	98.92	49.46	00:00:10	No
24.02.2013 04:45:30	24.02.2013 04:45:40	99.28	49.64	00:00:10	No
24.02.2013 06:49:40	24.02.2013 06:49:50	99.16	49.58	00:00:10	No
24.02.2013 08:12:00	24.02.2013 08:12:10	98.44	49.22	00:00:10	No
24.02.2013 09:19:00	24.02.2013 09:19:10	97.55	48.78	00:00:10	No
24.02.2013 10:23:10	24.02.2013 10:23:20	98.77	49.39	00:00:10	No
24.02.2013 11:34:10	24.02.2013 11:34:20	97.04	48.52	00:00:10	No
24.02.2013 11:55:30	24.02.2013 11:55:40	97.51	48.76	00:00:10	No
24.02.2013 12:03:50	24.02.2013 12:04:00	98.48	49.24	00:00:10	No
24.02.2013 12:39:50	24.02.2013 12:40:00	98.28	49.14	00:00:10	No
24.02.2013 13:19:10	24.02.2013 13:19:20	98.07	49.04	00:00:10	No
24.02.2013 14:14:30	24.02.2013 14:14:40	98.66	49.33	00:00:10	No
24.02.2013 15:36:20	24.02.2013 15:36:30	97.12	48.56	00:00:10	No
24.02.2013 16:08:10	24.02.2013 16:08:20	97.38	48.69	00:00:10	No
24.02.2013 16:29:00	24.02.2013 16:29:10	98.90	49.45	00:00:10	No
24.02.2013 19:18:40	24.02.2013 19:18:50	97.22	48.61	00:00:10	No
24.02.2013 20:31:20	24.02.2013 20:31:30	97.71	48.86	00:00:10	No
24.02.2013 21:45:20	24.02.2013 21:45:30	98.66	49.33	00:00:10	No
24.02.2013 22:50:50	24.02.2013 22:51:00	98.76	49.38	00:00:10	No
25.02.2013 00:45:50	25.02.2013 00:46:00	97.69	48.85	00:00:10	No
25.02.2013 09:16:10	25.02.2013 09:16:20	98.83	49.42	00:00:10	No
25.02.2013 12:34:40	25.02.2013 12:34:50	97.04	48.52	00:00:10	No
25.02.2013 13:51:40	25.02.2013 13:51:50	97.87	48.94	00:00:10	No

Figure 43: Display of all or non-flagged events

Multiphase events

According to standard EN 50160 events (interruptions, dips, swells) should be multiphase aggregated.

Multiphase aggregation is a method where events, which occur in all phases at a same time, are substituted with a single multiphase event since they were most likely triggered by a single anomaly in a network.

However, to eliminate possibility of lose of information all events should be recorded. Therefore during multiphase anomaly four events are recorded. Three events for each phase and an additional multiphase event.

Start	End	Phase	Minimum [%]	Minimum [V]	Duration
7.1.2013 11:06:02.097	7.1.2013 11:06:06.886	-	0,04	0,09	00:00:04.789
7.1.2013 11:06:02.097	7.1.2013 11:06:06.886	3	0,04	0,09	00:00:04.789
7.1.2013 11:06:07.327	7.1.2013 11:06:07.377	-	25,80	59,34	00:00:00.050
7.1.2013 11:06:07.327	7.1.2013 11:06:07.377	3	25,80	59,34	00:00:00.050

Figure 44: "Phase" column in a list of events marks multiphase event with "-". In this example two events occur in 3rd line and events are multiphase events.

Definition for multiphase dip and swell is:

“Multiphase event starts when voltage on one or more phases crosses threshold line for event detection and ends when voltage on all phases is restored to normal value”.

Definition for multiphase interruption is:

“Multiphase interruption starts when voltage on all three phases crosses threshold line for interruption detection and ends when voltage on at least one phase is restored to normal value”.

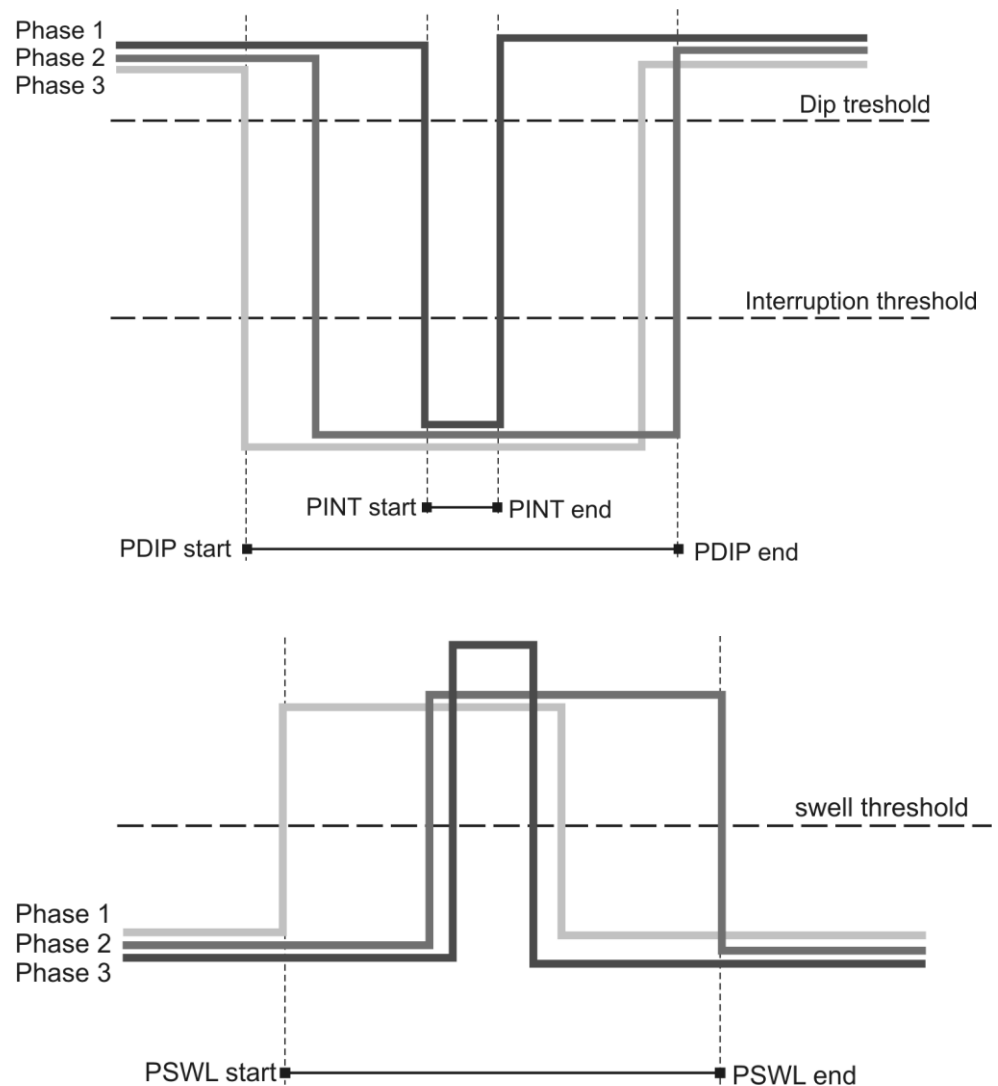

Figure 45: Graphical presentation of multiphase (PDIP, PINT, PSWL) event detection

Voltage event details are displayed in two ways. First as a list of all events with all details and second in a table according to UNIPEDD DISDIP specifications.

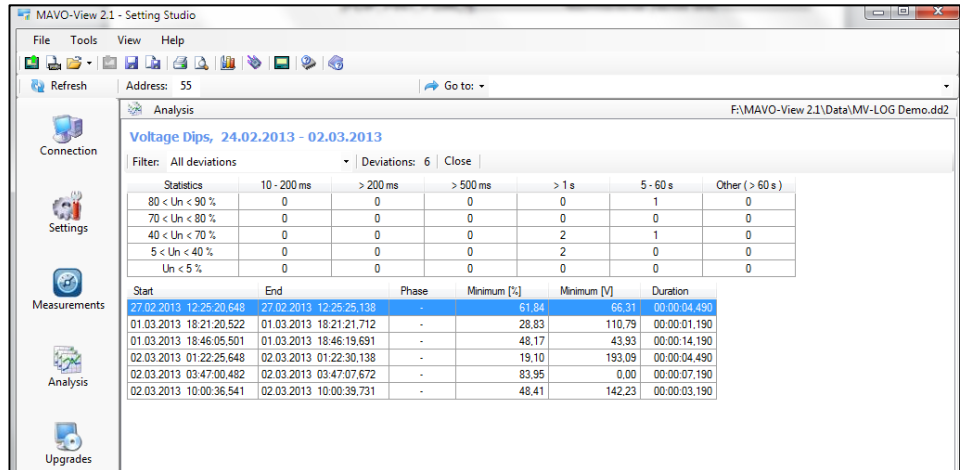

Figure 46: Presentation of Dips and Interruptions in a list (only four events) and in a statistics table

COMMUNICATION MODES

MAVOLOG PRO Quality Analyser supports two communication modes to suit all demands about connectivity and flexibility.

Standard PULL communication mode is used for most user interaction purposes in combination with monitoring and setting software MAVO-View, SCADA systems and other MODBUS oriented data acquisition software.

PUSH communication mode is used for sending unsolicited data to predefined links for storing data do various data bases.

PULL COMMUNICATION MODE **140**

PUSH COMMUNICATION MODE **141**

PULL communication mode

This is most commonly used communication mode. It services data-on-demand and is therefore suitable for direct connection of setting and / or supervising software to a single device or for a network connection of multiple devices, which requires setting up an appropriate communication infrastructure.

Data is sent from device when it is asked by external software according to MODBUS RTU or MODBUS TCP protocol.

This type of communication is normally used for a real-time on-demand measurement collection for control purposes.

To set up PULL communication mode, only basic communication settings are required according to communication type (serial, USB, ETHERNET). See chapter *Communication on page 56*.

PUSH communication mode

PUSH communication mode is mainly used for GOSSEN METRAWATT **MAVO-Database** system for remote monitoring, analysis and reporting.

The most extensive benefits when using **MAVOLOG PRO Quality Analyser** are achieved when device is used as a part of an energy monitoring system comprising of strategically positioned meters connected to **MAVO-Database** software solution. This three-tier middleware software represents a perfect tool for utility companies, energy suppliers and other parties on both ends of supply-demand chain.

MAVO-Database data collector with “push” communication system allows automatic records of all predefined measuring parameters. They are stored in

MAVO-Database database, while leaving a copy of same parameters stored locally in memory of each device as a backup copy. Database records in XML format can be searched and viewed in tabular and graphical form using **MAVO-Database client** or used by third-party application software.

Database records can involve numerous parameters of three-phase system, power quality parameters, physical parameters (temp., pressure, wind speed...) as well as alarms and event logs.

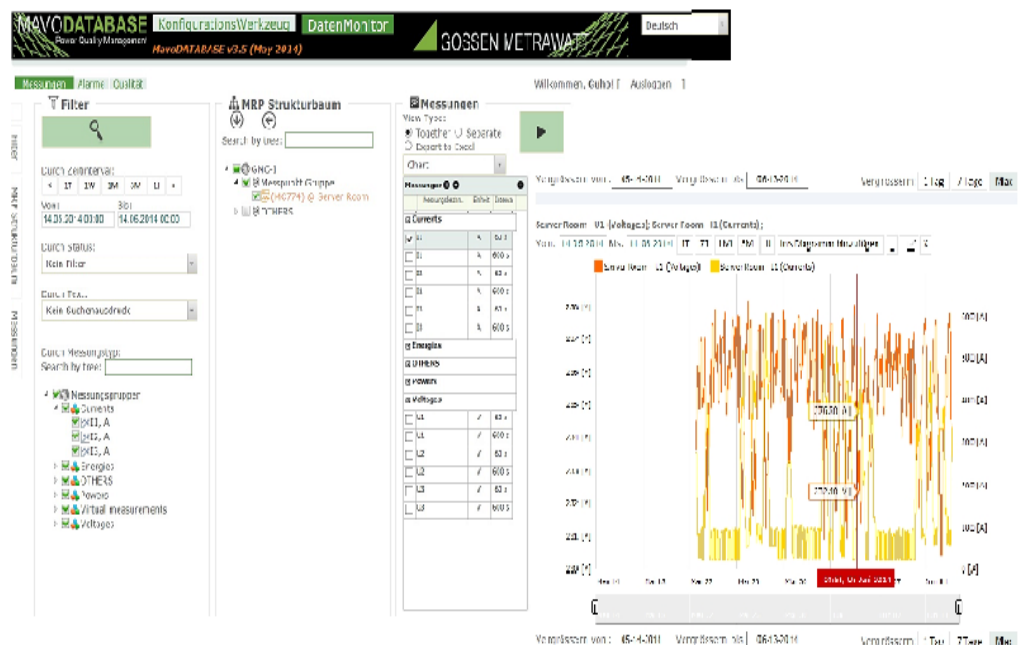

Figure 47: MAVO-Database client window

Explanation

When in this communication mode, device (master) is sending values of predefined quantities in predefined time intervals to two independent servers (data collectors - slave), who collect data into data base for further analysis.

This mode of communication is very useful for a periodic monitoring of readings in systems where real-time data are not required, but on the other side, reliability for collecting data is essential (e.g. for billing purposes, post processing and issuing trend warnings).

On the other hand, when operating in this mode, the device will send information about alarms immediately as they occur (real time alarm monitoring).

This type of communication also optimizes communication traffic.

Protocol and data format

Device uses XML format to send the data, which is very common and easy to use also for third party software solutions. Protocol used for data transmission is TCP/IP.

All sent readings are time-stamped for accurate reconstruction of received data (if communication is lost and data is sent afterwards). Therefore time synchronization of client and server is essential. For that purpose, server sends synchronization data packet to the device within every response to received data. If time difference is higher than +/- 2s, device resets its internal clock. For more information about used XML format see *Appendix D on page 180*.

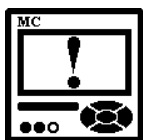

CAUTION

Time synchronisation with push system has the lowest priority. If any of other time synchronisation sources is available (GPS, NTP, IRIG-B) they have priority to synchronise RTC.

By using time synchronisation with push functionality device does not meet requirements for Class A measuring device and can be used only as a Class S measuring device.

Data transmission

Every transmission from master side (device) must be acknowledged from client side (server) to verify successful data transmission. In case client fails to receive acknowledgment after predefined response time (see *Ethernet communication on page 59*) it will retry to send it in next time interval. This repeating of sending data will last until master responses to sent data. After that, client will send all available data from the moment it lost response from the master.

It is possible for PULL and PUSH communication mode to be active at the same time. Both communication modes can be handled at the same time if PULL communication is made over COM2 or over Ethernet module through port reserved for communication over MODBUS communication protocol (port 502 see chapter *Ethernet communication on page 59*).

Supported quantities and settings

Sending data in PUSH communication mode is closely related with storing measurements in a recorder. Device can send to the selected server(s) a block of measure quantities that are stored in memory. For each memory division (recorders A to D, alarms recorder and quality reports with details recorder) separate settings can be made.

Step 1

With MAVO-View software set proper PUSH Communication settings where time synchronization source, response time, data format and receiving server's parameters are defined.

Step 2

Define data (quantities) for recorder / transmission. For each part of the recorder select to which of the server(s) data will data be sent. This setting can be made for Alarms, Recorder A to D, Quality reports and details.

More information about PUSH data transfer and MAVO-Database system for collecting of this data can be found on the GOSSSEN METRAWATT web page or in documentation about MAVO-Database system.

TECHNICAL DATA

In following chapter all technical data regarding operation of **MAVOLOG PRO Quality Analyser** is presented.

ACCURACY	145
INPUTS	147
CONNECTION	148
COMMUNICATION	148
I/O MODULES	149
SAFETY	151
OPERATING CONDITIONS	152
DIMENSIONS	153

Accuracy

Measured values	Measuring Range (Direct connection)	Accuracy class	
		Standard	Class
Active power	1.8 – 18 kW ($I_n = 5$ A)	IEC61557-12	0.2
	0 – 1.8 kW ($I_n = 1$ A)	IEC61557-12	0.5
Reactive power	0 – 18 kvar	IEC61557-12	1
Apparent power	0 – 18 kVA	IEC61557-12	0.2
Active energy	9 digit	IEC61557-12	0.2S
Reactive energy	9 digit	IEC61557-12	2
Apparent energy	9 digit	IEC61557-12	0.2
Rms current (I_1, I_2, I_3, I_{avg}) (I_{n_meas}) (I_{n_calc})	0,001 to 12.5 Arms	IEC61557-12	
	$I_n = 1$ A or 5A		0.1
	$I_n = 1$ A or 5A ⁽¹⁾		0.2
	$I_n = 1$ A or 5A		0.5
Rms phase voltage ($U_1, U_2, U_3, U_{n-g}, U_{avg}$)	$U_{meas}: 10 - 600$ V _{L-N}	IEC61557-12	0.1
	$U_{din} = 120/230$ V	IEC61000-4-30	Class A
Rms phase-to-phase voltage ($U_{12}, U_{23}, U_{31}, U_{avg}$)	18 - 1000 V _{L-L}	IEC61557-12	0.1
		IEC61000-4-30	Class A
Voltage negative sequence unbalance ⁽²⁾ (u_2)	10 - 600 V _{L-N}	IEC61557-12	0.2
		IEC61000-4-30	Class A
Voltage zero sequence unbalance ⁽²⁾ (u_0)	10 - 600 V _{L-N}	IEC61557-12	0.2
		IEC61000-4-30	Class A
Voltage flicker (Pst, Plt)	0.2 Pst – 10 Pst	IEC61000-4-15	Class F1 ⁽²⁾
		IEC61000-4-30	Class A
Frequency – momentary (f)	50 / 60Hz	IEC61557-12	0.02
		IEC61000-4-30	Class A
Frequency - (10 s average) (f_{10s})	50 / 60 Hz	IEC61557-12	0.02
		IEC61000-4-30	Class A
Nominal frequency range	16...400 Hz	IEC61557-12	0.02

Measured values	Measuring Range (Direct connection)	Accuracy class	
		Standard	Class
Power factor (PF_A)	-1(C)...0...+1(L)	IEC61557-12	0.5
Voltage swells (U_{swl})	100 – 120 % U_{din}	IEC61557-12 IEC61000-4-30	0.2, ±1 cyc Class A
Voltage dips (U_{dip})	5 – 100 % U_{din}	IEC61557-12 IEC61000-4-30	0.2, ±1 cyc Class A
Voltage interruptions (U_{int})	0 – 5 % U_{din}	IEC61557-12 IEC61000-4-30	±1 cyc Class A
THDU ⁽³⁾	10 – 200% of IEC61000-4-2 Class 3 Up to 4kHz	IEC61557-12 IEC61000-4-7 IEC61000-4-30	0.3 Class I Class A
Voltage harmonics (U_{h-l-n} , U_{h-l-l})	10 – 200% of IEC61000-4-2 Class 3 Up to 4kHz (63 rd)	IEC61557-12 IEC61000-4-7 IEC61000-4-30	0.15 Class I Class A
Voltage interharmonics (U_{lh})	10 – 200% of IEC61000-4-2 Class 3	IEC61000-4-7 IEC61000-4-30	Class I Class A
THDI ⁽⁴⁾	Up to 4kHz	IEC61557-12	0.3
Current harmonics (I_h)	Up to 4kHz (63 rd)	IEC61557-12	0.5
Signalling voltage (U_{msv})	Up to 3kHz	IEC61000-4-30	Class A
Real time clock (RTC)	synchronised unsynchronised	IEC61000-4-30	Class A < ±1 sec/day

- (1) Accurate measurements of neutral current (I_{n_meas}) at lower frequencies (16Hz – 30Hz) are possible up to 6Arms
- (2) Voltage unbalance is measured as amplitude and phase unbalance U_{nb}
- (3) Test specifications for flickermeter according to standard IEC61000-4-15:2010
- (4) When measuring THD, user can set how it is calculated (as a % of fundamental or as a % from RMS value)

Inputs

Voltage input	Number of channels	4 ⁽¹⁾
	Sampling rate	32 kHz
	Min. voltage for sync.	1 V _{rms}
	Nominal value (U _N)	500 V _{LN} , 866 V _{LL}
	Max. measured value (cont.)	600 V _{LN} ; 1000 V _{LL}
	Max. allowed value	1.2 × U _N permanently 2 × U _N ; 10 s
	Consumption	< U ² / 4.2 MΩ per phase
	Input impedance	4.2 MΩ per phase
<small>⁽¹⁾ 4th channel is used for measuring U_{EARTH-NEUTRAL}</small>		
Current input	Number of channels	4
	Sampling rate	32 kHz
	Nominal value (I _N)	1A, 5 A
	Max. measured value	12.5 A sinusoidal
	Max. allowed value (thermal)	15 A cont. ≤ 300 A; 1s
	Consumption	< I ² × 0.01Ω per phase
Frequency	Nominal frequency (f _n)	50, 60 Hz
	Measuring range	16...400 Hz
Supply	Feature A00 (Standard):	CAT III 300V
	Nominal voltage AC	80 ... 276 V
	Nominal frequency	40 ... 65 Hz
	Nominal voltage DC	70 ... 300 V
	Consumption (max. all I/O)	< 8VA
	Power-on transient current	< 20 A ; 1 ms
	Feature A01 (no longer available):	CAT III 300V
	Nominal voltage AC	48 ... 77 V
	Nominal frequency	40 ... 65 Hz
	Nominal voltage DC	19 ... 70 V
	Consumption (max. all I/O)	< 8VA
	Power-on transient current	< 20 A ; 1 ms

Connection

Permitted conductor cross-sections

Terminals	Max. conductor cross-sections
Voltage inputs (4)	2,5 mm ² with pin terminal 4 mm ² solid wire
Current inputs (3)	≤ Ø 6 mm one conductor with insulation
Supply (3)	2,5 mm ² with pin terminal 4 mm ² solid wire
Modules 1, 2 (2 x 3)	2,5 mm ² with pin terminal 4 mm ² solid wire
Modules A, B (2 x 9)	2,5 mm ² with pin terminal 4 mm ² solid wire
Module C (1 x 7)	2,5 mm ² with pin terminal 4 mm ² solid wire

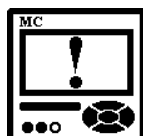

WARNING

It is imperative that terminal 12 which represents fourth voltage measurement channel is connected to earth pole ONLY. This terminal should be connected to EARTH potential at all times!

Communication

	Ethernet	USB	RS232	RS485
Type of connection	Network	Direct		Network
Max. connection length	30 m	2m	3 m	1000 m
Terminals	RJ-45	USB - B	Screw terminals	
Insulation	In accordance with EN 61010-1:2010 standard			
Transfer mode	Asynchronous			
Protocol	MODBUS TCP / DNP3 auto detect	MODBUS RTU / DNP3 auto detect		
Transfer rate	10/100Mb/s	2.400 to 115.200 bit/s		

I/O Modules

Digital output module	Type	Relay switch
	Purpose	2 x Alarm output, 2 x General purpose digital output
	Rated voltage	230 V _{AC/DC} ± 20% max
	Max. switching current	1000 mA (main slot) 100 mA (aux. slot)
	Contact resistance	≤ 100 mΩ (100 mA, 24V)
	Pulse	Max. 4000 imp/hour Min. length 100 ms
Bistable alarm output module	No. Of outputs	1
	Max. switching power	40 VA
	Rated voltage	230 V _{AC/DC} ± 20% max
	Max. switching current	1000 mA
	Contact resistance	≤ 100 mΩ (100 mA, 24V)
Status (Watchdog) output module	Type	Relay switch
	Number of outputs	1 x watchdog + 1 x relay output
	Normal operation	Relay in ON position
	Failure detection delay	≈ 1.5 s
	Rated voltage	230 V _{AC/DC} ±20% max
	Max. switching current	1000 mA
	Contact resistance	≤ 100 mΩ (100 mA, 24V)
Pulse output module	Type	Optocoupler open collector switch
	Purpose	Pulse output
	Rated voltage	40 V _{AC/DC}
	Max. switching current	30 mA (R _{ONmax} = 8 Ω)
	Pulse length	programmable (2 ... 999 ms)
Analogue output module	Output range	0...20 mA
	Accuracy	0.5% of range
	Max. burden	150 Ω
	Linearization	Linear, Quadratic
	No. of break points	5
	Output value limits	± 120% of nominal output
	Response time (measurement and analogue output)	depends on set general average interval
		(0.1s – 5s)
	Residual ripple	< 1 % p.p.

Time sync. input module C	Digital input 1pps voltage level Max. consumption on +5V terminal Time code telegram AM analog input Carrier frequency Input impedance Amplitude Modulation ration	GPS or IRIG-B TTL TTL level (+5V) 100 mA RS232 (GPS) DC level shift (IRIG-B) IRIG-B AM modulated 1 kHz 600 Ohms 2.5VP-Pmin, 8VP-Pmax 3:1 – 6:1
Analogue input module		
<i>DC current input</i>	Nominal input range 1 input resistance accuracy temperature drift conversion resolution Analogue input mode	-20...0...20 mA ($\pm 20\%$) 20 Ω 0.5 % of range 0.01% / $^{\circ}\text{C}$ 16 bit (sigma-delta) internally referenced Single-ended
<i>DC voltage input</i>	Nominal input range1 input resistance accuracy temperature drift conversion resolution Analogue input mode	-10...0...10 V ($\pm 20\%$) 100 k Ω 0.5 % of range 0.01% / $^{\circ}\text{C}$ 16 bit (sigma-delta) internally referenced Single-ended
<i>Resistance/ temperature Input module</i>	Nominal input range (low)* Nominal input range (high)* connection accuracy conversion resolution Analogue input mode	0 - 200 Ω (max. 400 Ω) PT100 (-200 $^{\circ}\text{C}$ –850 $^{\circ}\text{C}$) 0 – 2 k Ω (max. 4 k Ω) PT1000 (-200 $^{\circ}\text{C}$ –850 $^{\circ}\text{C}$) 2-wire 0.5 % of range 16 bit (sigma-delta) internally referenced Single-ended
* Low or high input range and primary input value (resistance or temperature) are set by the MAVO-View setting software		

Tariff input module	No. of inputs	2
	Voltage	5 ... 48 V AC/DC * 110 ±20% V AC/DC * 230 ±20% V AC/DC *
* Depends on a built in hardware		
Digital input module	No. of inputs	2
	Voltage	5 ... 48 V AC/DC * 110 ±20% V AC/DC * 230 ±20% V AC/DC *
* Depends on built in hardware		
Pulse input module	Rated voltage	5 – 48 V DC (±20%)
	Max. Current	8 mA (at 48 V DC + 20%)
	Min. pulse width	0.5 ms
	Min. pulse period	2 ms
	SET voltage	40 ... 120 % of rated voltage
	RESET voltage	0 ... 10 % of rated voltage

Safety

Safety	protection class II
$\tau \sigma$	In compliance with EN 61010-1:2010 600 V rms, CAT II 300 V rms, CAT III Pollution degree 2
Test voltage	Uaux against SELV circuits - 3.51 kV rms Other circuits to functional earth – 2.21 kV rms
EMC	Directive on electromagnetic compatibility 2004/108/EC In compliance with EN 61326-1:2006 for industrial environment
Protection	In compliance with EN 60529: 1997/A1:2000 Front side (with protection cover for memory slot): IP40 Rear side (with protection cover): IP20

Operating conditions

Operating conditions which have been tested for proper operation of a device within specified accuracy are in accordance with requirements in standards IEC 61557-12, IEC 61326-1, IEC 61000-4-30 and IEC 61000-4-7

<p>Ambient conditions</p>	<p>Ambient temperature K55 temperature class Acc. to EN 61557-12 -10...55 °C</p> <p>Storage temperature range -40 to +70 °C</p> <p>Ambient humidity ≤ 75% r.h. (no condensation)</p> <p>Max. storage and transport humidity ≤ 90% r.h. (no condensation)</p> <p>Voltage and Current max. temperature influence limit ± 20 ppm / K (10V-600V; 0,05A-10A) (T_{amb} : -30°C to +70°C)</p>
<p>Influence of Auxiliary Supply</p>	<p>Voltage and Current max. aux. supply change influence limit (IEC61557-12) < ± 0,02 % (Supply voltage magnitude and frequency in a specified range)</p> <p>Common mode input voltage rejection (IEC61557-12) < ± 0,08 % (common mode voltage at 500V)</p>
<p>Influence of EMC</p>	<p>External A.C. field IEC61326-1 < ±0,02 % Performance criteria A</p> <p>Electrostatic discharges IEC61326-1 (IEC61000-4-2) Performance criteria B</p> <p>Electromagnetic RF fields IEC61326-1 (IEC61000-4-3) Limit 1%; < ±0,4 % ^(a) Performance criteria A</p> <p>Conducted disturbances IEC61326-1 (IEC61000-4-6) Limit 1%; < ±0,4 % ^(a) Performance criteria A</p> <p>^(a) Test performed my measuring active energy with pulse output. Error (0.4%) is due to short measuring time</p>

Dimensions

Dimensional drawing

<i>Construction</i>	<i>Appearance</i>														
<i>Dimensions</i>	<p>All dimensions are in mm</p>														
<i>Panel cut-out</i>															
<i>Enclosure</i>	<table border="0"> <tr> <td>Dimensions</td> <td>144 × 144 × 100 mm</td> </tr> <tr> <td>Mounting</td> <td>Panel mounting 144 × 144 mm</td> </tr> <tr> <td>Required mounting hole</td> <td>137 × 137 mm</td> </tr> <tr> <td>Enclosure material</td> <td>PC/ABS</td> </tr> <tr> <td>Flammability</td> <td>Acc. to UL 94 V-0</td> </tr> <tr> <td>Weight</td> <td>550 g</td> </tr> <tr> <td>Enclosure material</td> <td>PC/ABS Acc. to UL 94 V-0</td> </tr> </table>	Dimensions	144 × 144 × 100 mm	Mounting	Panel mounting 144 × 144 mm	Required mounting hole	137 × 137 mm	Enclosure material	PC/ABS	Flammability	Acc. to UL 94 V-0	Weight	550 g	Enclosure material	PC/ABS Acc. to UL 94 V-0
Dimensions	144 × 144 × 100 mm														
Mounting	Panel mounting 144 × 144 mm														
Required mounting hole	137 × 137 mm														
Enclosure material	PC/ABS														
Flammability	Acc. to UL 94 V-0														
Weight	550 g														
Enclosure material	PC/ABS Acc. to UL 94 V-0														

Connection table

Function			Connection	Comment
Measuring input:	AC current	IL1	1/3	τ CAT II 600V CAT III 300V
		IL2	4/6	
		IL3	7/9	
		ILN	26/27	
	AC voltage	UL1	2	τ CAT II 600V CAT III 300V
		UL2	5	
		UL3	8	
		UN	11	
Inputs / outputs:	Module 1/2	$\varpi+$	15	
		$\varpi-$ (common)	16	
		$\varpi+$	17	
	Module 3/4	$\varpi+$	18	
		$\varpi-$ (common)	19	
		$\varpi+$	20	
	Module A	ϖ	30-38	
	Module B	ϖ	40-48	
	Module C	ϖ	52-58	
Auxiliary power supply:	+ / AC (L)	13	τ α CAT III 300V GROUND terminal must be always connected !!	
	- / AC (N)	14		
	GROUND	12		
Communication:	RS485	A	21	RS232 and RS485 are both supported, but only one at the time can be used! In case of Ethernet / USB communication, terminals from 21 to 25 are not used (unconnected).
		B	22	
	RS232	RX	23	
		GND	24	
		TX	25	

APPENDIX A: MODBUS communication protocol

Communication protocols

Modbus and DNP3 protocol are enabled via RS232 and RS485 or Ethernet communication. Both communication protocols are supported on all communication ports of the device. The response is the same type as the request.

Modbus

Modbus protocol enables operation of device on Modbus networks. For device with serial communication the Modbus protocol enables point to point (for example Device to PC) communication via RS232 communication and multi drop communication via RS485 communication. Modbus protocol is a widely supported open interconnect originally designed by Modicon.

In this document main modbus registers are listed. For complete, latest, Modbus table please visit the GOSSEN METRAWATT web site.

The memory reference for input and holding registers is 30000 and 40000 respectively.



PLEASE NOTE

For the latest and complete MODBUS table please visit the GOSSEN METRAWATT web page.

Register table for up-to-date measurements

Parameter	MODBUS		
	Register		Type
	Start	End	
Current time	30101	30104	T_Time
Frequency	30105	30106	T5
Voltage U ₁	30107	30108	T5
Voltage U ₂	30109	30110	T5
Voltage U ₃	30111	30112	T5
Average phase Voltage U ⁻	30113	30114	T5
Phase to phase voltage U ₁₂	30118	30119	T5
Phase to phase voltage U ₂₃	30120	30121	T5
Phase to phase voltage U ₃₁	30122	30123	T5
Average phase to phase Voltage U _{pp-}	30124	30125	T5
Voltage neutral to ground U _{no-}	30485	30486	T5
Current I ₁	30126	30127	T5
Current I ₂	30128	30129	T5
Current I ₃	30130	30131	T5
Neutral Current Inc (calculated)	30132	30133	T5
Neutral Current Inm (measured)	30134	30135	T5
Average Current	30136	30137	T5
Total Current I	30138	30139	T5
Real Power P ₁	30142	30143	T6
Real Power P ₂	30144	30145	T6
Real Power P ₃	30146	30147	T6
Total Real Power P	30140	30141	T6
Reactive Power Q1	30150	30151	T6
Reactive Power Q2	30152	30153	T6
Reactive Power Q3	30154	30155	T6
Total Reactive Power Q	30148	30149	T6
Apparent Power S1	30158	30159	T5
Apparent Power S2	30160	30161	T5
Apparent Power S3	30162	30163	T5
Total Apparent Power S	30156	30157	T5

Register table for up-to-date measurements (cont.)

Parameter	MODBUS		
	Register		Type
	Start	End	
Power Factor PF1	30166	30167	T7
Power Factor PF2	30168	30169	T7
Power Factor PF3	30170	30171	T7
Total Power Factor PF	30164	30165	T7
Power Angle U1-I1	30173		T17
Power Angle U2-I2	30174		T17
Power Angle U3-I3	30175		T17
Angle between In and Un	30488		T17
Power Angle atan2(Pt, Qt)	30172		T17
Angle U1-U2	30115		T17
Angle U2-U3	30116		T17
Angle U3-U1	30117		T17
Angle Un-U1	30487		T17
Voltage unbalance Uu	30176		T16
Voltage unb. zero sequence Uo	30177		T16
U1 Signal voltage Abs	30592	30593	T5
U2 Signal voltage Abs	30594	30595	T5
U2 Signal voltage Abs	30596	30597	T5
THD I1	30188		T16
THD I2	30189		T16
THD I3	30190		T16
THD U1	30182		T16
THD U2	30183		T16
THD U3	30184		T16
THD U12	30185		T16
THD U23	30186		T16
THD U31	30187		T16
Internal Temperature	30181		T2

Register table up-to-date measurements (cont.)

Parameter	MODBUS		
	Register		Type
	Start	End	
Max Demand Since Last RESET			
MD Real Power P (positive)	30542	30543	T6
MD Real Power P (negative)	30548	30549	T6
MD Reactive Power Q – L	30554	30555	T6
MD Reactive Power Q – C	30560	30561	T6
MD Apparent Power S	30536	30537	T5
MD Current I1	30518	30519	T5
MD Current I2	30524	30525	T5
MD Current I3	30530	30531	T5
Dynamic Demand Values			
MD Real Power P (positive)	30510	30511	T6
MD Real Power P (negative)	30512	30513	T6
MD Reactive Power Q – L	30514	30515	T6
MD Reactive Power Q – C	30516	30517	T6
MD Apparent Power S	30508	30509	T5
MD Current I1	30502	30503	T5
MD Current I2	30504	30505	T5
MD Current I3	30506	30507	T5

Register table for up-to-date measurements (cont.)

Parameter	MODBUS		
	Register		Type
	Start	End	
Energy			
Energy Counter 1 Exponent	30401		T2
Energy Counter 2 Exponent	30402		T2
Energy Counter 3 Exponent	30403		T2
Energy Counter 4 Exponent	30404		T2
Counter E1	30406	30407	T3
Counter E2	30408	30409	T3
Counter E3	30410	30411	T3
Counter E4	30412	30413	T3
Counter E1 Tariff 1	30414	30415	T3
Counter E2 Tariff 1	30416	30417	T3
Counter E3 Tariff 1	30418	30419	T3
Counter E4 Tariff 1	30420	30421	T3
Counter E1 Tariff 2	30422	30423	T3
Counter E2 Tariff 2	30424	30425	T3
Counter E3 Tariff 2	30426	30427	T3
Counter E4 Tariff 2	30428	30429	T3
Counter E1 Tariff 3	30430	30431	T3
Counter E2 Tariff 3	30432	30433	T3
Counter E3 Tariff 3	30434	30435	T3
Counter E4 Tariff 3	30436	30437	T3
Counter E1 Tariff 4	30438	30439	T3
Counter E2 Tariff 4	30440	30441	T3
Counter E3 Tariff 4	30442	30443	T3
Counter E4 Tariff 4	30444	30445	T3
Counter E1 Cost	30446	30447	T3
Counter E2 Cost	30448	30449	T3
Counter E3 Cost	30450	30451	T3
Counter E4 Cost	30452	30453	T3
Active tariff	30405		T1

Up-to-date
counter is
calculated:
Cnt.x 10^{exponent}

Register table for up-to-date measurements (cont.)

Parameter	MODBUS		
	Register		Type
	Start	End	
Flickers			
Flicker Pst1	30580		T17
Flicker Pst2	30581		T17
Flicker Pst3	30582		T17
Flicker Plt1	30583		T17
Flicker Plt2	30584		T17
Flicker Plt3	30585		T17
Flicker Pf5 - L1	30586	30587	T5
Flicker Pf5 - L2	30588	30589	T5
Flicker Pf5 - L3	30590	30591	T5
Phase voltage harmonic data			
U1 Harmonic Data			
Base for % calculation	31001	31002	T5
U1 1 Harmonic Abs %	31003		T16
U1 1 Harmonic Phase Angle	31004		T17
U1 Harmonics from 2 to 62			
U1 63 Harmonic Abs %	31127		T16
U1 63 Harmonic Phase Angle	31128		T17
U2 Harmonic Data			
Base for % calculation	31129	31130	T5
U2 1 Harmonic Abs %	31131		T16
U2 1 Harmonic Phase Angle	31132		T17
U2 Harmonics from 2 to 62			
U2 63 Harmonic Abs %	31255		T16
U2 63 Harmonic Phase Angle	31256		T17
U3 Harmonic Data			
Base for % calculation	31257	31258	T5
U3 2 Harmonic Abs %	31259		T16
U3 2 Harmonic Phase Angle	31260		T17
U3 Harmonics from 3rd to 30th			
U3 63 Harmonic Abs %	31383		T16
U3 63 Harmonic Phase Angle	31384		T17

Register table for up-to-date measurements (cont.)

Parameter	MODBUS		
	Register		Type
	Start	End	
Line voltage harmonic data			
U12 Harmonic Data			
Base for % calculation	31385	31386	T5
U12 1 Harmonic Abs %	31387		T16
U12 1 Harmonic Phase Angle	31388		T17
U12 Harmonics from 2 to 62			
U12 63 Harmonic Abs %	31511		T16
U12 63 Harmonic Phase Angle	31512		T17
U23 Harmonic Data			
Base for % calculation	31513	31514	T5
U23 1 Harmonic Abs %	31515		T16
U23 1 Harmonic Phase Angle	31516		T17
U23 Harmonics from 2 to 62			
U23 63 Harmonic Abs %	31639		T16
U23 63 Harmonic Phase Angle	31640		T17
U31 Harmonic Data			
Base for % calculation	31641	31642	T5
U31 2 Harmonic Abs %	31643		T16
U31 2 Harmonic Phase Angle	31644		T17
U31 Harmonics from 3rd to 30th			
U31 63 Harmonic Abs %	31767		T16
U31 63 Harmonic Phase Angle	31768		T17

Register table for up-to-date measurements (cont.)

Parameter	MODBUS		
	Register		Type
	Start	End	
Phase current harmonic data			
I1 Harmonic Data			
Base for % calculation	31769	31770	T5
I1 1 Harmonic Abs %	31771		T16
I1 1 Harmonic Phase Angle	31772		T17
I1 Harmonics from 2 to 62			
I1 63 Harmonic Abs %	31895		T16
I1 63 Harmonic Phase Angle	31896		T17
I2 Harmonic Data			
Base for % calculation	31897	31898	T5
I2 1 Harmonic Abs %	31899		T16
I2 1 Harmonic Phase Angle	31900		T17
I2 Harmonics from 2 to 62			
I2 63 Harmonic Abs %	32023		T16
I2 63 Harmonic Phase Angle	32024		T17
I3 Harmonic Data			
Base for % calculation	32025	32026	T5
I3 2 Harmonic Abs %	32027		T16
I3 2 Harmonic Phase Angle	32028		T17
I3 Harmonics from 3rd to 30th			
I3 63 Harmonic Abs %	32151		T16
I3 63 Harmonic Phase Angle	32152		T17

Register table for up-to-date measurements (cont.)

Parameter	MODBUS		
	Register		Type
	Start	End	
Phase voltage interharmonic data			
U1 Interharmonic Data			
Base for % calculation	32153	32154	T5
1. Interharmonic Abs %	32155		T16
2. Interharmonic Abs %	32156		T16
3. - 10 Interharmonic	32157	32164	T16
U2 Interharmonic Data			
Base for % calculation	3271	3272	T5
1. Interharmonic Abs %	32173		T16
2. Interharmonic Abs %	32174		T16
3. - 10 Interharmonic	32175	32182	T16
U3 Interharmonic Data			
Base for % calculation	32189	32190	T5
1. Interharmonic Abs %	32191		T16
2. Interharmonic Abs %	32192		T16
3. - 10 Interharmonic	32193	32200	T16

All other MODBUS registers are a subject to change. For the latest MODBUS register definitions go to GOSSEN METRAWATT web page www.gossenmetrawatt.com.

Register table for the basic settings

Register	Content	Type	Ind	Values / Dependencies	Min	Max	Pass. Level
40143	Connection Mode	T1	0	No mode	1	5	2
			1	1b - Single Phase			
			2	3b - 3 phase 3 wire balanced			
			3	4b - 3 phase 4 wire balanced			
			4	3u - 3 phase 3 wire unbalanced			
			5	4u - 3 phase 4 wire unbalanced			
40144	CT Secondary	T4		mA			2
40145	CT Primary	T4		A/10			2
40146	VT Secondary	T4		mV			2
40147	VT Primary	T4		V/10			2
40148	Current input range (%)	T16		10000 for 100%	5,00	200,00	2
40149	Voltage input range (%)	T16		10000 for 100%	2,50	100,00	2
40150	Frequency nominal value	T1		Hz	10	1000	2

Data types decoding

Type	Bit mask	Description
T1		Unsigned Value (16 bit) Example: 12345 = 3039(16)
T2		Signed Value (16 bit) Example: -12345 = CFC7(16)
T3		Signed Long Value (32 bit) Example: 123456789 = 075B CD 15(16)
T4	bits # 15...14 bits # 13...00	Short Unsigned float (16 bit) Decade Exponent(Unsigned 2 bit) Binary Unsigned Value (14 bit) Example: 10000*102 = A710(16)
T5	bits # 31...24 bits # 23...00	Unsigned Measurement (32 bit) Decade Exponent(Signed 8 bit) Binary Unsigned Value (24 bit) Example: 123456*10-3 = FD01 E240(16)
T6	bits # 31...24 bits # 23...00	Signed Measurement (32 bit) Decade Exponent (Signed 8 bit) Binary Signed value (24 bit) Example: - 123456*10-3 = FDFE 1DC0(16)
T7	bits # 31...24 bits # 23...16 bits # 15...00	Power Factor (32 bit) Sign: Import/Export (00/FF) Sign: Inductive/Capacitive (00/FF) Unsigned Value (16 bit), 4 decimal places Example: 0.9876 CAP = 00FF 2694(16)
T9	bits # 31...24 bits # 23...16 bits # 15...08 bits # 07...00	Time (32 bit) 1/100s 00 - 99 (BCD) Seconds 00 - 59 (BCD) Minutes 00 - 59 (BCD) Hours 00 - 24 (BCD) Example: 15:42:03.75 = 7503 4215(16)

Data types decoding (cont.)

Type	Bit mask	Description
T10	bits # 31...24 bits # 23...16 bits # 15...00	Date (32 bit) Day of month 01 - 31 (BCD) Month of year 01 - 12 (BCD) Year (unsigned integer) 1998..4095 Example: 10, SEP 2000 = 1009 07D0(16)
T16		Unsigned Value (16 bit), 2 decimal places Example: 123.45 = 3039(16)
T17		Signed Value (16 bit), 2 decimal places Example: -123.45 = CFC7(16)
T_float	bits # 31 bits # 31 bits # 31	IEEE 754 Floating-Point Single Precision Value (32bit) Sign Bit (1 bit) Exponent Field (8 bit) Significand (23 bit) Example: 123.45 stored as 123.45000 = 42F6 E666(16)
T_Str4		Text: 4 characters (2 characters for 16 bit register)
T_Str6		Text: 6 characters (2 characters for 16 bit register)
T_Str8		Text: 8 characters (2 characters for 16 bit register)
T_Str16		Text: 16 characters (2 characters for 16 bit register)
T_Str40		Text: 40 characters (2 characters for 16 bit register)

APPENDIX B: DNP3 Communication Protocol

Communication protocols

Modbus and DNP3 protocol are enabled via RS232 and RS485 or Ethernet communication. Both communication protocols are supported on all communication ports of the device. The response is the same type as the request.

DNP3

DNP3 protocol enables operation of a device on DNP3 networks. For device with serial communication the DNP3 protocol enables point to point (for example device to PC) communication via RS232 communication and multi drop communication via RS485.

Device automatically responses to MODBUS or DNP3 request.



PLEASE NOTE

For the latest and complete DNP3 table please visit [GOSSEN METRAWATT](#) web page.

DNP 3.0 Device Profile Document		Issue: E Date: 8 Jan 2013	
Device Name: Measurement centre Vendor Name: GOSSEN METRAWATT Models Covered: MAVOLOG PRO			
Highest DNP Level Supported: For Requests: 1 For Responses: 1		Device Function: <input type="checkbox"/> Master <input checked="" type="checkbox"/> Slave	
Notable objects, functions, and/or qualifiers supported in addition to the Highest DNP Levels Supported (the complete list is described in the DNP V3.0 Implementation table):			
Maximum Data Link Frame Size (octets): Transmitted: 292 Received: 249 Maximum Data Link Re-tries: <input checked="" type="checkbox"/> None <input type="checkbox"/> Configurable		Maximum Application Fragment Size (octets): Transmitted: 2048 Received: 249 Maximum Application Layer Re-tries: <input checked="" type="checkbox"/> None <input type="checkbox"/> Configurable	
Requires Data Link Layer Confirmation: <input checked="" type="checkbox"/> Never <input type="checkbox"/> Always <input type="checkbox"/> Sometimes <input type="checkbox"/> Configurable			
Requires Application Layer Confirmation: <input checked="" type="checkbox"/> Never <input type="checkbox"/> Always <input type="checkbox"/> Sometimes <input type="checkbox"/> Configurable			

Timeouts while waiting for: Data Link Confirm: <input checked="" type="checkbox"/> None <input type="checkbox"/> Fixed at ____ <input type="checkbox"/> Variable <input type="checkbox"/> Configurable Complete Appl. Fragment: <input checked="" type="checkbox"/> None <input type="checkbox"/> Fixed at ____ <input type="checkbox"/> Variable <input type="checkbox"/> Configurable Application Confirm: <input checked="" type="checkbox"/> None <input type="checkbox"/> Fixed at ____ <input type="checkbox"/> Variable <input type="checkbox"/> Configurable Complete Appl. Response: <input checked="" type="checkbox"/> None <input type="checkbox"/> Fixed at ____ <input type="checkbox"/> Variable <input type="checkbox"/> Configurable Others:	
Sends/Executes Control Operations: WRITE Binary Outputs <input checked="" type="checkbox"/> Never <input type="checkbox"/> Always <input type="checkbox"/> Sometimes <input type="checkbox"/> Configurable SELECT/OPERATE <input checked="" type="checkbox"/> Never <input type="checkbox"/> Always <input type="checkbox"/> Sometimes <input type="checkbox"/> Configurable DIRECT OPERATE <input checked="" type="checkbox"/> Never <input type="checkbox"/> Always <input type="checkbox"/> Sometimes <input type="checkbox"/> Configurable DIRECT OPERATE – NO ACK <input checked="" type="checkbox"/> Never <input type="checkbox"/> Always <input type="checkbox"/> Sometimes <input type="checkbox"/> Configurable Count > 1 <input checked="" type="checkbox"/> Never <input type="checkbox"/> Always <input type="checkbox"/> Sometimes <input type="checkbox"/> Configurable Pulse On <input checked="" type="checkbox"/> Never <input type="checkbox"/> Always <input type="checkbox"/> Sometimes <input type="checkbox"/> Configurable Pulse Off <input checked="" type="checkbox"/> Never <input type="checkbox"/> Always <input type="checkbox"/> Sometimes <input type="checkbox"/> Configurable Latch On <input checked="" type="checkbox"/> Never <input type="checkbox"/> Always <input type="checkbox"/> Sometimes <input type="checkbox"/> Configurable Latch Off <input checked="" type="checkbox"/> Never <input type="checkbox"/> Always <input type="checkbox"/> Sometimes <input type="checkbox"/> Configurable Queue <input checked="" type="checkbox"/> Never <input type="checkbox"/> Always <input type="checkbox"/> Sometimes <input type="checkbox"/> Configurable Clear Queue <input checked="" type="checkbox"/> Never <input type="checkbox"/> Always <input type="checkbox"/> Sometimes <input type="checkbox"/> Configurable	
Reports Binary Input Change Events when no specific variation requested: <input checked="" type="checkbox"/> Never <input type="checkbox"/> Only non-time-tagged <input type="checkbox"/> Configurable	Reports time-tagged Binary Input Change Events when no specific variation requested: <input checked="" type="checkbox"/> <input checked="" type="checkbox"/> Never <input type="checkbox"/> Binary Input Change With Relative Time <input type="checkbox"/> <input type="checkbox"/> Configurable
Sends Unsolicited Responses: <input checked="" type="checkbox"/> Never <input type="checkbox"/> Configurable <input type="checkbox"/> Only certain Objects <input type="checkbox"/> Sometimes <input type="checkbox"/> ENABLE/DISABLE UNSOLICITED Function codes supported	Sends Static Data in Unsolicited Responses: <input checked="" type="checkbox"/> <input checked="" type="checkbox"/> Never <input type="checkbox"/> When Device Restarts <input type="checkbox"/> When Status Flags Change No other options are permitted.
Default Counter Object/Variation: <input type="checkbox"/> No Counters Reported <input type="checkbox"/> Configurable <input checked="" type="checkbox"/> Default Object: 30 <input checked="" type="checkbox"/> Default Variation: 4 Point-by-point list attached	Counters Roll Over at: <input type="checkbox"/> No Counters Reported <input type="checkbox"/> Configurable <input type="checkbox"/> 16 Bits <input type="checkbox"/> 32 Bits <input checked="" type="checkbox"/> Other Value: 20000 Point-by-point list attached
Sends Multi-Fragment Responses: <input type="checkbox"/> Yes <input checked="" type="checkbox"/> No	

Object			Request			Response	
Object Number	Variation Number	Description	Function Codes (dec)	Qualifier Codes (hex)	Function Codes (dec)	Qualifier Codes (hex)	
0	242	Device Attributes - software version	1	00	129	00, 17	
0	243	Device Attributes – hardware version	1	00	129	00, 17	
0	246	Device Attributes – user assigned ID	1	00	129	00, 17	
0	248	Device Attributes – serial number	1	00	129	00, 17	
0	250	Device Attributes – product name	1	00	129	00, 17	
0	252	Device Attributes – manufacture name	1	00	129	00, 17	
0	254	Device Attributes – nonspecific all attributes request	1	00, 06			
0	255	Device Attributes – list of attribute variation	1	00, 06	129	00, 5B	
Points for object 0							
0	Software version	T_Str3	Data	var	242		
0	Hardware version	T_Str2	Data	var	243		
0	user assigned ID	T_Str2	Data	var	246		
0	serial number	T_Str8	Data	var	248		
0	product name	T_Str16	Data	var	250		
0	manufacture name	T_Str20	Data	var	252		

Object			Request		Response	
Object Number	Variation Number	Description	Function Codes (dec)	Qualifier Codes (hex)	Function Codes (dec)	Qualifier Codes (hex)
10	0	Binary output status	1	00, 01, 06		
10	2	Binary output status	1	00, 01, 06	129	00, 01
Points for object 10						
0	Relay 1	T1	Data	0	1	
1	Relay 2	T1	Data	0	1	
2	Relay 3	T1	Data	0	1	
3	Relay 4	T1	Data	0	1	
4	Slot A - Relay 1	T1	Data	0	1	
5	Slot A - Relay 2	T1	Data	0	1	
6	Slot A - Relay 3	T1	Data	0	1	
7	Slot A - Relay 4	T1	Data	0	1	
8	Slot A - Relay 5	T1	Data	0	1	
9	Slot A - Relay 6	T1	Data	0	1	
10	Slot A - Relay 7	T1	Data	0	1	
11	Slot A - Relay 8	T1	Data	0	1	
12	Slot B - Relay 1	T1	Data	0	1	
13	Slot B - Relay 2	T1	Data	0	1	
14	Slot B - Relay 3	T1	Data	0	1	
15	Slot B - Relay 4	T1	Data	0	1	
16	Slot B - Relay 5	T1	Data	0	1	
17	Slot B - Relay 6	T1	Data	0	1	
18	Slot B - Relay 7	T1	Data	0	1	
19	Slot B - Relay 8	T1	Data	0	1	

Object			Request			Response	
Object Number	Variation Number	Description	Function Codes (dec)	Qualifier Codes (hex)	Function Codes (dec)	Qualifier Codes (hex)	
30	0	16-Bit Analog Input without flag	1	00, 01, 06			
30	2	16-Bit Analog Input with flag	1	00, 01, 06	129	00, 01	
30	4	16-Bit Analog Input without flag	1	00, 01, 06	129	00, 01	
Points for object 30							
0	U1	T16	Data	-Un	+Un		
1	U2	T16	Data	-Un	+Un		
2	U3	T16	Data	-Un	+Un		
3	Uavg (phase to neutral)	T16	Data	-Un	+Un		
4	U12	T16	Data	-Un	+Un		
5	U23	T16	Data	-Un	+Un		
6	U31	T16	Data	-Un	+Un		
7	Uavg (phase to phase)	T16	Data	-Un	+Un		
8	I1	T16	Data	-In	+In		
9	I2	T16	Data	-In	+In		
10	I3	T16	Data	-In	+In		
11	I total	T16	Data	-In	+In		
12	I neutral (calculated)	T16	Data	-In	+In		
13	I neutral (measured)	T16	Data	-In	+In		
14	Iavg	T16	Data	-In	+In		
15	Active Power Phase L1 (P1)	T17	Data	-Pn	+Pn		
16	Active Power Phase L2 (P2)	T17	Data	-Pn	+Pn		
17	Active Power Phase L3 (P3)	T17	Data	-Pn	+Pn		
18	Active Power Total (Pt)	T17	Data	-Pt	+Pt		
19	Reactive Power Phase L1 (Q1)	T17	Data	-Pn	+Pn		
20	Reactive Power Phase L2 (Q2)	T17	Data	-Pn	+Pn		
21	Reactive Power Phase L3 (Q3)	T17	Data	-Pn	+Pn		
22	Reactive Power Total (Qt)	T17	Data	-Pt	+Pt		
23	Apparent Power Phase L1 (S1)	T16	Data	-Pn	+Pn		
24	Apparent Power Phase L2 (S2)	T16	Data	-Pn	+Pn		
25	Apparent Power Phase L3 (S3)	T16	Data	-Pn	+Pn		
26	Apparent Power Total (St)	T16	Data	-Pt	+Pt		
27	Power Factor Phase 1 (PF1)	T17	Data	-1	+1		
28	Power Factor Phase 2 (PF2)	T17	Data	-1	+1		
29	Power Factor Phase 3 (PF3)	T17	Data	-1	+1		

Points for object 30 cont.							
30	Power Factor Total (PFt)	T17		Data	-1	+1	
31	CAP/IND P. F. Phase 1 (PF1)	T17		Data	-1 CAP	+1	300% for -1 IND
32	CAP/IND P. F. Phase 2 (PF2)	T17		Data	-1 CAP	+1	300% for -1 IND
33	CAP/IND P. F. Phase 3 (PF3)	T17		Data	-1 CAP	+1	300% for -1 IND
34	CAP/IND P. F. Total (PFt)	T17		Data	-1 CAP	+1	300% for -1 IND
35	j1 (angle between U1 and I1)	T17		Data	-100°	+100°	
36	j2 (angle between U2 and I2)	T17		Data	-100°	+100°	
37	j3 (angle between U3 and I3)	T17		Data	-100°	+100°	
38	Power Angle Total (atan2(Pt,Qt))	T17		Data	-100°	+100°	
39	j12 (angle between U1 and U2)	T17		Data	-100°	+100°	
40	j23 (angle between U2 and U3)	T17		Data	-100°	+100°	
41	j31 (angle between U3 and U1)	T17		Data	-100°	+100°	
42	Frequency	T17		Data	Fn-10Hz	Fn+10Hz	
43	U unbalance	T16		Data	-100%	+100%	
44	I1 THD%	T16		Data	-100%	+100%	
45	I2 THD%	T16		Data	-100%	+100%	
46	I3 THD%	T16		Data	-100%	+100%	
47	U1 THD%	T16		Data	-100%	+100%	
48	U2 THD%	T16		Data	-100%	+100%	
49	U3 THD%	T16		Data	-100%	+100%	
50	U12 THD%	T16		Data	-100%	+100%	
51	U23 THD%	T16		Data	-100%	+100%	
52	U31 THD%	T16		Data	-100%	+100%	
	MAX DEMAND SINCE LAST RESET						
53	Active Power Total (Pt) - (positive)	T16		Data	-Pt	+Pt	
54	Active Power Total (Pt) - (negative)	T16		Data	-Pt	+Pt	
55	Reactive Power Total (Qt) - L	T16		Data	-Pt	+Pt	
56	Reactive Power Total (Qt) - C	T16		Data	-Pt	+Pt	
57	Apparent Power Total (St)	T16		Data	-Pt	+Pt	
58	I1	T16		Data	-In	+In	
59	I2	T16		Data	-In	+In	
60	I3	T16		Data	-In	+In	
	DYNAMIC DEMAND VALUES						
61	Active Power Total (Pt) - (positive)	T16		Data	-Pt	+Pt	

Points for object 30 cont.							
62	Active Power Total (Pt) - (negative)	T16		Data	-Pt	+Pt	
63	Reactive Power Total (Qt) - L	T16		Data	-Pt	+Pt	
64	Reactive Power Total (Qt) - C	T16		Data	-Pt	+Pt	
65	Apparent Power Total (St)	T16		Data	-Pt	+Pt	
66	I1	T16		Data	-In	+In	
67	I2	T16		Data	-In	+In	
68	I3	T16		Data	-In	+In	
	ENERGY						
69	Energy Counter 1	T17		Data			(32-bit value) MOD 20000
70	Energy Counter 2	T17		Data			(32-bit value) MOD 20000
71	Energy Counter 3	T17		Data			(32-bit value) MOD 20000
72	Energy Counter 4	T17		Data			(32-bit value) MOD 20000
73	Energy Counter 1 Cost	T17		Data			(32-bit value) MOD 20000
74	Energy Counter 2 Cost	T17		Data			(32-bit value) MOD 20000
75	Energy Counter 3 Cost	T17		Data			(32-bit value) MOD 20000
76	Energy Counter 4 Cost	T17		Data			(32-bit value) MOD 20000
77	Total Energy Counter Cost	T17		Data			(32-bit value) MOD 20000
78	Aktiv Tarif	T1		Data			
79	Internal Temperature	T17		Data	-100°	+100°	

Object			Request		Response	
Object Number	Variation Number	Description	Function Codes (dec)	Qualifier Codes (hex)	Function Codes (dec)	Qualifier Codes (hex)
40	0	16-bit Analog output status	1	00, 01, 06		
40	2	16-bit Analog output status	1	00, 01, 06	129	00, 01
Points for object 40						
0	Analog output 1	T1	Data	0		
1	Analog output 2	T1	Data	0		
2	Analog output 3	T1	Data	0		
3	Analog output 4	T1	Data	0		
4	Slot A - Analog output 1	T1	Data	0		
5	Slot A - Analog output 2	T1	Data	0		
6	Slot A - Analog output 3	T1	Data	0		
7	Slot A - Analog output 4	T1	Data	0		
8	Slot B - Analog output 1	T1	Data	0		
9	Slot B - Analog output 2	T1	Data	0		
10	Slot B - Analog output 3	T1	Data	0		
11	Slot B - Analog output 4	T1	Data	0		

Object			Request		Response	
Object Number	Variation Number	Description	Function Codes (dec)	Qualifier Codes (hex)	Function Codes (dec)	Qualifier Codes (hex)
50	0	Time and Date – absolute time	2	7		
50	1	Time and Date – absolute time	2	7	129	7
Points for object 50						
0	Time and Date	T_Time	Data			

Object			Request		Response	
Object Number	Variation Number	Description	Function Codes (dec)	Qualifier Codes (hex)	Function Codes (dec)	Qualifier Codes (hex)
60	1	CLASS 0 DATA	1	06		
60	2	CLASS 1 DATA	1,22*	06		
60	3	CLASS 2 DATA	1,22*	06		
60	4	CLASS 3 DATA	1,22*	06		

*only object 30

APPENDIX C: EQUATIONS

Definitions of symbols

No	Symbol	Definition
1	M_P	Average interval
2	U_f	Phase voltage (U_1, U_2 or U_3)
3	U_{ff}	Phase-to-phase voltage (U_{12}, U_{23} or U_{31})
4	N	Total number of samples in a period
5	n	Sample number ($0 \leq n \leq N$)
6	x, y	Phase number (1, 2 or 3)
7	i_n	Current sample n
8	U_{fn}	Phase voltage sample n
9	U_{ffn}	Phase-to-phase voltage sample n
10	φ_f	Power angle between current and phase voltage f (φ_1, φ_2 or φ_3)
11	U_u	Voltage unbalance
12	U_c	Agreed supply voltage

Voltage

$$U_f = \sqrt{\frac{\sum_{n=1}^N u_n^2}{N}}$$

Phase voltage

N – samples in averaging interval
(up to 65 Hz)

$$U_{xy} = \sqrt{\frac{\sum_{n=1}^N (u_{xn} - u_{yn})^2}{N}}$$

Phase-to-phase voltage

u_x, u_y – phase voltages (U_f)

N – a number of samples in averaging interval

$$U_u = \sqrt{\frac{1 - \sqrt{3 - 6\beta}}{1 + \sqrt{3 - 6\beta}}} \cdot 100\%$$

Voltage unbalance

U_{fund} – first harmonic of phase-to-phase voltage

$$\beta = \frac{U_{12fund}^4 + U_{23fund}^4 + U_{31fund}^4}{(U_{12fund}^2 + U_{23fund}^2 + U_{31fund}^2)^2}$$

Current

$$I_{RMS} = \sqrt{\frac{\sum_{n=1}^N i_n^2}{N}}$$

Phase current

N – samples in averaging interval
(up to 65 Hz)

$$I_n = \sqrt{\frac{\sum_{n=1}^N (i_{1n} + i_{2n} + i_{3n})^2}{N}}$$

Neutral current

i – n sample of phase current (1, 2 or 3)

N – samples in averaging interval
(up to 65 Hz)

Power

$P_f = \frac{1}{N} \cdot \sum_{n=1}^N (u_{fn} \cdot i_{fn})$	<p>Active power by phases N – a number of periods n – index of sample in a period f – phase designation</p>
$P_t = P_1 + P_2 + P_3$	<p>Total active power t – total power 1, 2, 3 – phase designation</p>
<p>Sign$Q_f(\varphi)$ $\varphi \in [0^\circ - 180^\circ] \Rightarrow \text{Sign}Q_f(\varphi) = +1$ $\varphi \in [180^\circ - 360^\circ] \Rightarrow \text{Sign}Q_f(\varphi) = -1$</p>	<p>Reactive power sign Q_f – reactive power (by phases) φ – power angle</p>
$S_f = U_f \cdot I_f$	<p>Apparent power by phases U_f – phase voltage I_f – phase current</p>
$S_t = S_1 + S_2 + S_3$	<p>Total apparent power S_f – apparent power by phases</p>
$Q_f = \text{Sign}Q_f(\varphi) \cdot \sqrt{S_f^2 - P_f^2}$	<p>Reactive power by phases S_f – apparent power by phases P_f – active power by phases</p>
$Q_f = \frac{1}{N} \cdot \sum_{n=1}^N (u_{fn} \times i_{f[n+N/4]})$	<p>Reactive power by phases (delayed current method) N – a number of samples in a period n – sample number (0 ≤ n ≤ N) f – phase designation</p>
$Q_t = Q_1 + Q_2 + Q_3$	<p>Total reactive power Q_f – reactive power by phases</p>
<p>$\varphi_s = \arctan 2(P_t, Q_t)$ $\varphi_s = [-180^\circ, 179,99^\circ]$</p>	<p>Total power angle P_t – total active power Q_t – total reactive power</p>
$PF_t = \frac{P_t}{S_t}$	<p>Distortion factor P_t – total active power S_t – total apparent power</p>
$PF_f = \frac{P_f}{S_f}$	<p>Distortion factor P_t – phase active power S_t – phase apparent power</p>

THD

$$I_f THD(\%) = \frac{\sqrt{\sum_{n=2}^{63} I_n^2}}{I_1} \cdot 100$$

Current THDI₁ – value of first harmonic

n – number of harmonic

$$U_f THD(\%) = \frac{\sqrt{\sum_{n=2}^{63} U_{fn}^2}}{U_{f1}} \cdot 100$$

Phase voltage THDU₁ – value of first harmonic

n – number of harmonic

$$U_{ff} THD(\%) = \frac{\sqrt{\sum_{n=2}^{63} U_{ffn}^2}}{U_{ff1}} \cdot 100$$

Phase-to-phase voltage THDU₁ – value of first harmonic

n – number of harmonic

Flickers

$$P_{50S} = (P_{30} + P_{50} + P_{80})/3$$

$$P_{10S} = (P_6 + P_8 + P_{10} + P_{13} + P_{17})/5$$

$$P_{3S} = (P_{2,2} + P_3 + P_4)/3$$

$$P_{1S} = (P_{1,7} + P_1 + P_{1,5})/3$$

$$P_{st} = \sqrt{0,0314P_{0,1} + 0,0525P_{1S} + 0,0657P_{3S} + 0,28P_{10S} + 0,08P_{50S}}$$

Pst – Short-term flicker intensity

Short-term flicker intensity is measured in 10 minute periods.

P_x – flicker levels that are exceeded by x% in a 10-minute period (e.g. P_{0,1} represents a flicker level that is exceeded by 0.1% samples)

$$P_{lt} = \sqrt[3]{\sum_{i=1}^{12} \frac{P_{sti}^3}{12}}$$

Plt – Long-term flicker intensity

Calculated from twelve successive values of short-term flicker intensity in a two-hour period

Energy

$$\text{Price in tariff} = \text{Price} \cdot 10^{\text{Tariff price exponent}}$$

Total exponent of tariff price and energy price in all tariffs

APPENDIX D: XML DATA FORMAT

Explanation of XML data format

All data, which is prepared to be sent at next time interval is combined into element `<data>`. It comprises of elements `<value>`, which contain all information regarding every single reading.

Attributes of element `<value>` are:

- *logId*: Identification code of data package. It is used as a confirmation key and should therefore be unique for each device.
- *app*: application type ??
- *storeType*: data type ("measurement" or "alarm") or quality report??
- *dataProvider*: "xml001" ??
- *controlUnit*: Serial number of the device that sent this data
- *part*: rekorder ??
- *datetimeUTC*: UTC date and time of the beginning of current time interval in which data was sent (yyyy-mm-dd hh:mm:ss).
- *ident*: ID code of particular reading
- *tFunc*: thermal function (1= ON / 0 = OFF)
- *cond*: condition (1 = lower than; 0 = higher then)
- *condVal*: limit value
- *almNum*: alarm serial number.
- *unit*: Measuring Parameter Unit (V, A, VA, W, VAr...)
- *tInterval*: sampling interval in minutes
- *dst*: (daylight savings time) in minutes
- *tzone*: timezone in minutes

Example of alarms `<data>` package

```
<data logId="033350088" app="ML" storeType="alarm" dataProvider="xml001"
controlUnit="MC004475" part="E" datetimeUTC="2009-07-15 21:29:07" dst="60" tzone=" 60">

  <value ident="U1  " unit="V  " tFunc="0" cond="0" condVal="200,00"
almNum="01">100</value>

  <value ident="U2  " unit="V  " tFunc="0" cond="0" condVal="200,00"
almNum="02">101</value>

  <value ident="U3  " unit="V  " tFunc="0" cond="0" condVal="200,00"
almNum="03">99</value>

</data>
```

Example of readings <data> package

```
<data logId="033324218" app="ML" storeType="measurement" dataProvider="xml001"
controlUnit="MC004475" part="B" datetimeUTC="2009-09-16 3:00:00" dst="60" tzone=" 60"
tInterval="015">
```

```
    <value ident="U1 " unit="V " ">234,47</value>
    <value ident="U2 " unit="V " ">234,87</value>
    <value ident="U3 " unit="V " ">234,52</value>
    <value ident="I1 " unit="A " ">1,14</value>
    <value ident="I2 " unit="A " ">1,50</value>
    <value ident="I3 " unit="A " ">3,58</value>
    <value ident="P1 " unit="W " ">-0,063e+03</value>
    <value ident="P2 " unit="W " ">-0,101e+03</value>
    <value ident="P3 " unit="W " ">0,281e+03</value>
    <value ident="P " unit="W " ">0,11e+03</value>
    <value ident="Q " unit="var " ">-1,37e+03</value>
    <value ident="E1 " unit="Wh">19620e+01</value>
    <value ident="E2 " unit="varh">6e+01</value>
    <value ident="E3 " unit="Wh">1303391e+01</value>
    <value ident="E4 " unit="varh">2999595e+01</value>
    <value ident="ePF " unit=" " ">0,0820</value>
</data>
```

Example of acknowledgement package:

```
<ack logId="033220002" datetimeUTC ="2008-01-31 23:00:50:000"></ack>
```

Product Support

If required please contact:

GMC-I Messtechnik GmbH
Product Support Hotline Industry
Phone +49 911 8602-500
Fax +49 911 8602-340
E-Mail support.industrie@gossenmetrawatt.com

Service Center

Repair and Replacement Parts Service Calibration Center and Rental Instrument Service

When you need service, please contact:

GMC-I Service GmbH
Service Center
Beuthener Straße 41
90471 Nürnberg • Germany
Phone +49 911 817718-0
Fax +49 911 817718-253
E-Mail service@gossenmetrawatt.com
www.gmci-service.com

This address is only valid in Germany.

Please contact our representatives or subsidiaries for service in other countries.

Edited in Germany • Subject to change without notice • A pdf version is available on the Internet