



Interface EMMOD203

Camille Bauer AG
CH-5610 Wohlen

Camille Bauer reserves the right
to change the content of this document
at any time without notice.



CAMILLE BAUER
Auf uns ist Verlass.

Table of contents

1. Introduction.....	2
2. Modbus implementation EMMOD203.....	2
3. Measurands acquisition.....	3
3.1 Present measurands	3
3.2 Minimum / Maximum values	5
3.3 Meter contents.....	7
3.4 Mean values	8
3.5 Mean values progression (Logger).....	10
3.6 Measurands overflow.....	11
4. Status interrogation / remote control	12
4.1 Status interrogation	12
4.2 Remote control of digital outputs	12
4.3 Setting tariff situation	12
4.4 Synchronization via bus interface.....	12
4.5 Firmware versions and device type	13
5. Resetting measurands	14
5.1 Resetting minimum and maximum values.....	14
5.2 Setting / resetting meters.....	15
6. Configuration	16
Appendix: Display matrices, system dependent.....	22

The basics for the understanding of the **MODBUS®** communication is summarised in a separated document:

"Modbus Basics.pdf" (available via our Website <http://www.camillebauer.com>)

Within that document you will find detailed telegram examples for **Modbus/TCP** communication.

MODBUS® - Modbus is a registered trade mark of Schneider Electric. Detailed protocol specifications are available via the Website <http://www.modbus.org>

Modification	Date	Vis.:	Type:	EMMOD203	Nr.: 1 / 24	gez.: 10.05.05	RR
			Description:	Definition Modbus/TCP interface	Zeichnr.:	W2416e	

1. Introduction

The devices of the A200 series of multi-functional power meters may be equipped with an optional extension module. Within this document the communication with the **module EMMOD203** is shown. It provides an Ethernet 10/100 MBit interface (RJ45 connector), memory for a logger with real time clock and two digital inputs. The communication is done by means of the standard protocols Modbus/TCP, HTTP and SNMP.

Basically three different operating modes may be realized:

- **Standalone:** The module is used for configuring the device only. There is no permanent connection to a master (PC) or it is not fixed all the time.
- **Bus service:** The devices are installed in an Ethernet network. Measured data are requested permanently via a MODBUS/TCP master.
- **Full device control via bus:** Beside the interrogation of measurands the synchronization of the mean power values, tariff switching and digital output driving (on-site alarming) may be performed via Ethernet interface. The MODBUS/TCP master is fully responsible for a permanent control of the devices and acquires measurands periodically.

The following functions can be performed using the extension module:

- Reading device features, modification of device features
- Acquisition of present measurands, mean-power values and mean values stored in the logger with time stamp
- Reading / setting / resetting of meter contents
- Resetting minimum / maximum values
- Synchronization, tariff switching or direct output driving of digital outputs via Ethernet interface

This document describes all these functions. For communication protocols according to the MODBUS/TCP specification are used. However, normally you will work with an existing hardware and / or software platform. Therefore we will give a help to various users which chapters of this document are of help for him.

MODBUS®tool user

3. Measurand acquisition

Engineer who wants to realize an independent measurand acquisition

3. Measurand acquisition
4. Status interrogation / remote control
5. Resetting measurands

2. Modbus implementation EMMOD203

Supported functions

Code	MODBUS® Function	Used for ...
03 _H	READ HOLDING REGISTERS	- Reading measurands, meter contents, mean values, logger data, configuration data etc.
08 _H	DIAGNOSTIC	- Using sub-function 0 the connection to the device may be tested
10 _H	PRESET MULTIPLE REGISTERS	- Configuring the device - Setting / resetting meters - Resetting minimum / maximum values

Modification	Date	Vis.:	Type: EMMOD203	Nr.: 2 / 24	gez.: 10.05.05 RR
			Description: Definition Modbus/TCP interface	Zeichnr.:	W2416e

3. Measurands acquisition

The power monitoring devices acquire the measurands of an electrical power system. These measurands and derived quantities may be requested via interface. This information can be roughly divided as follows:

1. Present measurands
2. Minimum / maximum values
3. Meter contents
4. Mean-power values (integrated for a synchronization interval)
5. Progression of mean-power values (Logger)

3.1 Present measurands

3.1.1 General present measurands

Register address	Measurand	single-phase / 3 or 4-wire balanced load systems	3-wire unb. system	4-wire unb. system	
100	U	☺	-	-	
102	U1N	-	-	☺	
104	U2N	-	-	☺	
106	U3N	-	-	☺	
108	U12	-	☺	☺	
110	U23	-	☺	☺	
112	U31	-	☺	☺	
114	I	☺	-	-	
116	I1	-	☺	☺	
118	I2	-	☺	☺	
120	I3	-	☺	☺	
122	Iavg	☺	-	-	
124	I1_avg	-	☺	☺	
126	I2_avg	-	☺	☺	
128	I3_avg	-	☺	☺	
130	IN	-	-	☺	
132	P1	-	-	☺	
134	P2	-	-	☺	
136	P3	-	-	☺	
138	P	☺	☺	☺	
140	Q1	-	-	☺	
142	Q2	-	-	☺	
144	Q3	-	-	☺	
146	Q	☺	☺	☺	
148	S1	-	-	☺	
150	S2	-	-	☺	
152	S3	-	-	☺	
154	S	☺	☺	☺	
156	F	☺	☺	☺	
158	PF1	-	-	☺	
160	PF2	-	-	☺	
162	PF3	-	-	☺	
164	PF	☺	☺	☺	
166	Umean	-	☺	☺	A230 only: Mean value of voltages
168	Imean	-	☺	☺	A230 only: Mean value of currents
170	UNE	-	-	☺	A230 only: Zero displacement voltage
172	Pint_tnd1	☺	☺	☺	A230 only: Mean power value P incoming (trend)
174	Qint_tnd1	☺	☺	☺	A230 only: Mean power value Q ind. / incoming (trend)
176	Sint_tnd	☺	☺	☺	A230 only: Mean power value S (trend)
178	Pint_tnd2	☺	☺	☺	A230 only: Mean power value P outg. (trend)
180	Qint_tnd2	☺	☺	☺	A230 only: Mean power value Q cap. / outg. (trend)

The active measurand of the reactive power intervals for the A230 arise from the configuration in 'Disp_Mode' (see chapter 6).

Legend: ☺ = Valid measurand - = Not used (value=0.00)

All values are 32-bit float numbers (2 registers for each value), scaled on primary values.

Modification	Date	Vis.:	Type:	EMMOD203	Nr.: 3 / 24	gez.: 10.05.05 RR
			Description:	Definition Modbus/TCP interface	Zeichnr.:	W2416e

3.1.2 Present measurands of unbalance / THD (A230 only)

Register address	Measurand	single-phase / 3 or 4-wire balanced load systems	3-wire unb. system	4-wire unb. system	
184	unb.U	-	-	●	Unbalance factor
185	THD.Ux	U	U12	U1	Harmonic content U / U12 / U1
186	THD.Ux	-	U23	U2	Harmonic content U23 / U2
187	THD.Ux	-	U31	U3	Harmonic content U31 / U3
188	THD.lx	I	I1	I1	Harmonic content I / I1
189	THD.lx	-	I2	I2	Harmonic content I2
190	THD.lx	-	I3	I3	Harmonic content I3

Legend: ● = Valid measurand - = Not used (value=0.00)

All these values are unsigned 16-bit numbers (1 register per value). 1000 corresponds to 100%.

3.1.3 Present harmonic contents (A230 only)

Register address	Measurand	single-phase / 3 or 4-wire balanced load systems	3-wire unb. system	4-wire unb. system	
600	H2.Ux	U	U12	U1N	2 nd harmonic content
601	H3.Ux	U	U12	U1N	3 rd harmonic content
...	Hn.Ux	U	U12	U1N	n th harmonic content
612	H14.Ux	U	U12	U1N	14 th harmonic content
613	H15.Ux	U	U12	U1N	15 th harmonic content
614	H2.Ux	-	U23	U2N	2 nd harmonic content
615	H3.Ux	-	U23	U2N	3 rd harmonic content
...	Hn.Ux	-	U23	U2N	n th harmonic content
626	H14.Ux	-	U23	U2N	14 th harmonic content
627	H15.Ux	-	U23	U2N	15 th harmonic content
628	H2.Ux	-	U31	U3N	2 nd harmonic content
629	H3.Ux	-	U31	U3N	3 rd harmonic content
...	Hn.Ux	-	U31	U3N	n th harmonic content
640	H14.Ux	-	U31	U3N	14 th harmonic content
641	H15.Ux	-	U31	U3N	15 th harmonic content
642	H2.lx	I	I1	I1	2 nd harmonic content
643	H3.lx	I	I1	I1	3 rd harmonic content
...	Hn.lx	I	I1	I1	n th harmonic content
654	H14.lx	I	I1	I1	14 th harmonic content
655	H15.lx	I	I1	I1	15 th harmonic content
656	H2.lx	-	I2	I2	2 nd harmonic content
657	H3.lx	-	I2	I2	3 rd harmonic content
...	Hn.lx	-	I2	I2	n th harmonic content
668	H14.lx	-	I2	I2	14 th harmonic content
669	H15.lx	-	I2	I2	15 th harmonic content
670	H2.lx	-	I3	I3	2 nd harmonic content
671	H3.lx	-	I3	I3	3 rd harmonic content
...	Hn.lx	-	I3	I3	n th harmonic content
682	H14.lx	-	I3	I3	14 th harmonic content
683	H15.lx	-	I3	I3	15 th harmonic content

All harmonic values are unsigned 16-bit numbers (1 register per value). 1000 corresponds to 100%. The values refer to the fundamental wave, which is fixed to 100%.

Modification	Date	Vis.:	Type: EMMOD203	Nr.: 4 / 24	gez.: 10.05.05 RR
			Description: Definition Modbus/TCP interface	Zeichnr.:	W2416e

3.2 Minimum / Maximum values

3.2.1 Minimum / Maximum values 1

Register address	Measurand	single-phase / 3 or 4-wire balanced load systems	3-wire unb. system	4-wire unb. system	
200	Umax	☉	-	-	
202	U1Nmax	-	-	☉	
204	U2Nmax	-	-	☉	
206	U3Nmax	-	-	☉	
208	U12max	-	☉	☉	
210	U23max	-	☉	☉	
212	U31max	-	☉	☉	
214	I1max	☉	-	-	
216	I1max	-	☉	☉	
218	I2max	-	☉	☉	
220	I3max	-	☉	☉	
222	Iavgmax	☉	-	-	
224	I1avgmax	-	☉	☉	
226	I2avgmax	-	☉	☉	
228	I3avgmax	-	☉	☉	
230	INmax	-	-	☉	
232	P1max	-	-	☉	
234	P2max	-	-	☉	
236	P3max	-	-	☉	
238	Pmax	☉	☉	☉	
240	Q1max	-	-	☉	
242	Q2max	-	-	☉	
244	Q3max	-	-	☉	
246	Qmax	☉	☉	☉	
248	S1max	-	-	☉	
250	S2max	-	-	☉	
252	S3max	-	-	☉	
254	Smax	☉	☉	☉	
256	Umin	☉	-	-	
258	U1Nmin	-	-	☉	
260	U2Nmin	-	-	☉	
262	U3Nmin	-	-	☉	
264	U12min	-	☉	☉	
266	U23min	-	☉	☉	
268	U31min	-	☉	☉	
270	PFmin.inc.ind	☉	☉	☉	A230 only: Incoming
272	PFmin.inc.cap	☉	☉	☉	A230 only: Incoming
274	PFmin.out.ind	☉	☉	☉	A230 only: Outgoing
276	PFmin.out.cap	☉	☉	☉	A230 only: Outgoing
278	Fmin	☉	☉	☉	A230 only
280	Fmax	☉	☉	☉	A230 only
282	UNEmax	-	-	☉	A230 only

Legend: ☉ = Valid measurand - = Not used (value=0.00)

All values are 32-bit float numbers (2 registers for each value), scaled on primary values.

Modification	Date	Vis.:	Type:	EMMOD203	Nr.: 5 / 24	gez.: 10.05.05 RR
			Description:	Definition Modbus/TCP interface	Zeichnr.:	W2416e

3.2.2 Maximum values of THD / harmonic contents (A230 only)

Register address	Measurand	single-phase / 3 or 4-wire balanced load systems	3-wire unb. system	4-wire unb. system	
700	unb.Umax	-	-	●	Unbalance U maximum
701	THD.Uxmax	U	U12	U1N	
702	THD.Uxmax	-	U23	U2N	
703	THD.Uxmax	-	U31	U3N	
704	THD.lxmax	I	I1	I1	
705	THD.lxmax	-	I2	I2	
706	THD.lxmax	-	I3	I3	
707	H2.Uxmax	U	U12	U1N	
708	H3.Uxmax	U	U12	U1N	
...	Hn.Uxmax	U	U12	U1N	
719	H14.Uxmax	U	U12	U1N	
720	H15.Uxmax	U	U12	U1N	
721	H2.Uxmax	-	U23	U2N	
722	H3.Uxmax	-	U23	U2N	
...	Hn.Uxmax	-	U23	U2N	
733	H14.Uxmax	-	U23	U2N	
734	H15.Uxmax	-	U23	U2N	
735	H2.Uxmax	-	U31	U3N	
736	H3.Uxmax	-	U31	U3N	
...	Hn.Uxmax	-	U31	U3N	
747	H14.Uxmax	-	U31	U3N	
748	H15.Uxmax	-	U31	U3N	
749	H2.lxmax	I	I1	I1	
750	H3.lxmax	I	I1	I1	
...	Hn.lxmax	I	I1	I1	
761	H14.lxmax	I	I1	I1	
762	H15.lxmax	I	I1	I1	
763	H2.lxmax	-	I2	I2	
764	H3.lxmax	-	I2	I2	
...	Hn.lxmax	-	I2	I2	
775	H14.lxmax	-	I2	I2	
776	H15.lxmax	-	I2	I2	
777	H2.lxmax	-	I3	I3	
778	H3.lxmax	-	I3	I3	
...	Hn.lxmax	-	I3	I3	
789	H14.lxmax	-	I3	I3	
790	H15.lxmax	-	I3	I3	

All harmonic values are unsigned 16-bit numbers (1 register per value). 1000 corresponds to 100%. The values refer to the fundamental wave, which is fixed to 100%.

Modification	Date	Vis.:	Type: EMMOD203	Nr.: 6 / 24	gez.: 10.05.05 RR
			Description: Definition Modbus/TCP interface	Zeichnr.:	W2416e

3.3 Meter contents

Register	No tariff switching	Tariff switching activated
300	P _{incoming}	P _{incoming} HT
302	-	P _{incoming} LT
304	P _{outgoing}	P _{outgoing} HT
306	-	P _{outgoing} LT
308	Q _{inductive / incoming}	Q _{inductive / incoming} HT
310	-	Q _{inductive / incoming} LT
312	Q _{capacitive / outgoing}	Q _{capacitive / outgoing} HT
314	-	Q _{capacitive / outgoing} LT

All meter contents are unsigned 32-bit integer numbers (2 registers for each value). These values refer to the significant numbers, which will be displayed on the display unit itself.

The active reactive power meters for the A230 arise from the configuration in 'Disp_Mode' (see chapter 6).

Unit factor

Register	No tariff switching	Tariff switching activated
320	Unit factor x	

The unit factor is an unsigned 16-bit integer number. It is used to scale the meter contents to the appropriate physical unit and to define the number of post decimal positions. It contains as well the conversion for possibly connected primary transformers.

$$\text{Physical meter content} = \text{Meter content} * 10^X \text{ [Wh or varh]}$$

Example: P_{incoming} = 12056; E = 4

Meter content: $12056 \times 10^4 \text{ [Wh]} = 12056 \times 10^6 \times 10^{-2} \text{ [Wh]} = \mathbf{120.56 \text{ [MWh]}}$

| |
[MWh] 2 post decimal positions

Modification	Date	Vis.:	Type: EMMOD203	Nr.: 7 / 24	gez.: 10.05.05 RR
			Description: Definition Modbus/TCP interface	Zeichnr.:	W2416e

3.4 Mean values

3.4.1 Mean-power values

Register	Measurand	A210 / A220	A230
350	P_int_0	Incoming-outgoing (Last value)	Incoming (Last value)
352	P_int_1	Incoming-outgoing (t – 1 interval)	Incoming (t – 1 interval)
354	P_int_2	Incoming-outgoing (t – 2 interval)	Incoming (t – 2 interval)
356	P_int_3	Incoming-outgoing (t – 3 interval)	Incoming (t – 3 interval)
358	P_int_4	Incoming-outgoing (t – 4 interval)	Incoming (t – 4 interval)
360	Q_int_0	Capac.+induct. (Last value)	Inductive / incoming (Last value)
362	Q_int_1	Capac.+induct. (t – 1 interval)	Inductive / incoming (t – 1 interval)
364	Q_int_2	Capac.+induct. (t – 2 interval)	Inductive / incoming (t – 2 interval)
366	Q_int_3	Capac.+induct. (t – 3 interval)	Inductive / incoming (t – 3 interval)
368	Q_int_4	Capac.+induct. (t – 4 interval)	Inductive / incoming (t – 4 interval)
370	S_int_0	t	t
372	S_int_1	t – 1 interval	t – 1 interval
374	S_int_2	t – 2 interval	t – 2 interval
376	S_int_3	t – 3 interval	t – 3 interval
378	S_int_4	t – 4 interval	t – 4 interval
380	P_int_0	-	Outgoing (Last value)
382	P_int_1	-	Outgoing (t – 1 interval)
384	P_int_2	-	Outgoing (t – 2 interval)
386	P_int_3	-	Outgoing (t – 3 interval)
388	P_int_4	-	Outgoing (t – 4 interval)
390	Q_int_0	-	Capacitive / outgoing (Last value)
392	Q_int_1	-	Capacitive / outgoing (t – 1 interval)
394	Q_int_2	-	Capacitive / outgoing (t – 2 interval)
396	Q_int_3	-	Capacitive / outgoing (t – 3 interval)
398	Q_int_4	-	Capacitive / outgoing (t – 4 interval)

The active measurand of the reactive power intervals for the A230 arise from the configuration in 'Disp_Mode' (see chapter 6). All values are 32-bit float numbers (2 registers for each value), scaled on primary values.

3.4.2 Maximum / Minimum of mean-power values (A230 only)

Register	Measurand	
330	P.inc-int.max	Incoming
332	Qx-int.max	Inductive / incoming
334	S.int.max	
336	P.out-int.max	Outgoing
338	Qx-int.max	Capacitive / outgoing
340	P.inc-int.min	Incoming
342	Qx-int.min	Inductive / incoming
344	S.int.min	
346	P.out-int.min	Outgoing
348	Qx-int.min	Capacitive / outgoing

The active measurand of the reactive power intervals for the A230 arise from the configuration in 'Disp_Mode' (see chapter 6). All values are 32-bit float numbers (2 registers for each value), scaled on primary values.

Modification	Date	Vis.:	Type:	EMMOD203	Nr.: 8 / 24	gez.: 10.05.05 RR
			Description:	Definition Modbus/TCP interface	Zeichnr.:	W2416e

3.4.3 Free configurable mean values (A230 only)

Register	Measurand	
800	Mean value 1	Trend
802	Mean value 2	Trend
804	Mean value 3	Trend
806	Mean value 4	Trend
808	Mean value 5	Trend
810	Mean value 6	Trend
812	Mean value 7	Trend
814	Mean value 8	Trend
816	Mean value 9	Trend
818	Mean value 1	Last value
820	Mean value 2	Last value
822	Mean value 3	Last value
824	Mean value 4	Last value
826	Mean value 5	Last value
828	Mean value 6	Last value
830	Mean value 7	Last value
832	Mean value 8	Last value
834	Mean value 9	Last value

The appropriate measurands arise from the configuration in 'Mean_Meas[0..8]' (see chapter 6).
All values are 32-bit float numbers (2 registers for each value), scaled on primary values.

3.4.4 Maximum / Minimum of configured mean values (A230 only)

Register	Measurand	
840	Mean value 1 max	Maximum
842	Mean value 2 max	Maximum
844	Mean value 3 max	Maximum
846	Mean value 4 max	Maximum
848	Mean value 5 max	Maximum
850	Mean value 6 max	Maximum
852	Mean value 7 max	Maximum
854	Mean value 8 max	Maximum
856	Mean value 9 max	Maximum
858	Mean value 1 min	Minimum
860	Mean value 2 min	Minimum
862	Mean value 3 min	Minimum
864	Mean value 4 min	Minimum
866	Mean value 5 min	Minimum
868	Mean value 6 min	Minimum
870	Mean value 7 min	Minimum
872	Mean value 8 min	Minimum
874	Mean value 9 min	Minimum

The appropriate measurands of these extreme values arise from the configuration in 'Mean_Meas[0..8]' (see chapter 6).
All values are 32-bit float numbers (2 registers for each value), scaled on primary values.

Modification	Date	Vis.:	Type: EMMOD203	Nr.: 9 / 24	gez.: 10.05.05 RR
			Description: Definition Modbus/TCP interface	Zeichnr.:	W2416e

3.5 Mean values progression (Logger)

The complete logger data is stored in the file 'log.dat'. This is a binary data file, which contains the recorded log sequences in the format ASN.1 BER. The file can be read from the device using the HTTP protocol. The MIME type of the file is „application/octet-stream“.

Access via browser:

http://<ip_addr>/log.dat (<ip_addr>: IP address of the device)

In application software a connection via TCP-Port 80 must be established first. Then the following request has to be sent to the device:

"GET /log.dat HTTP/1.1\r\n\r\n" (terminated by <CR><LF><CR><LF>)

The structure of the log file can be seen in the following graphic:

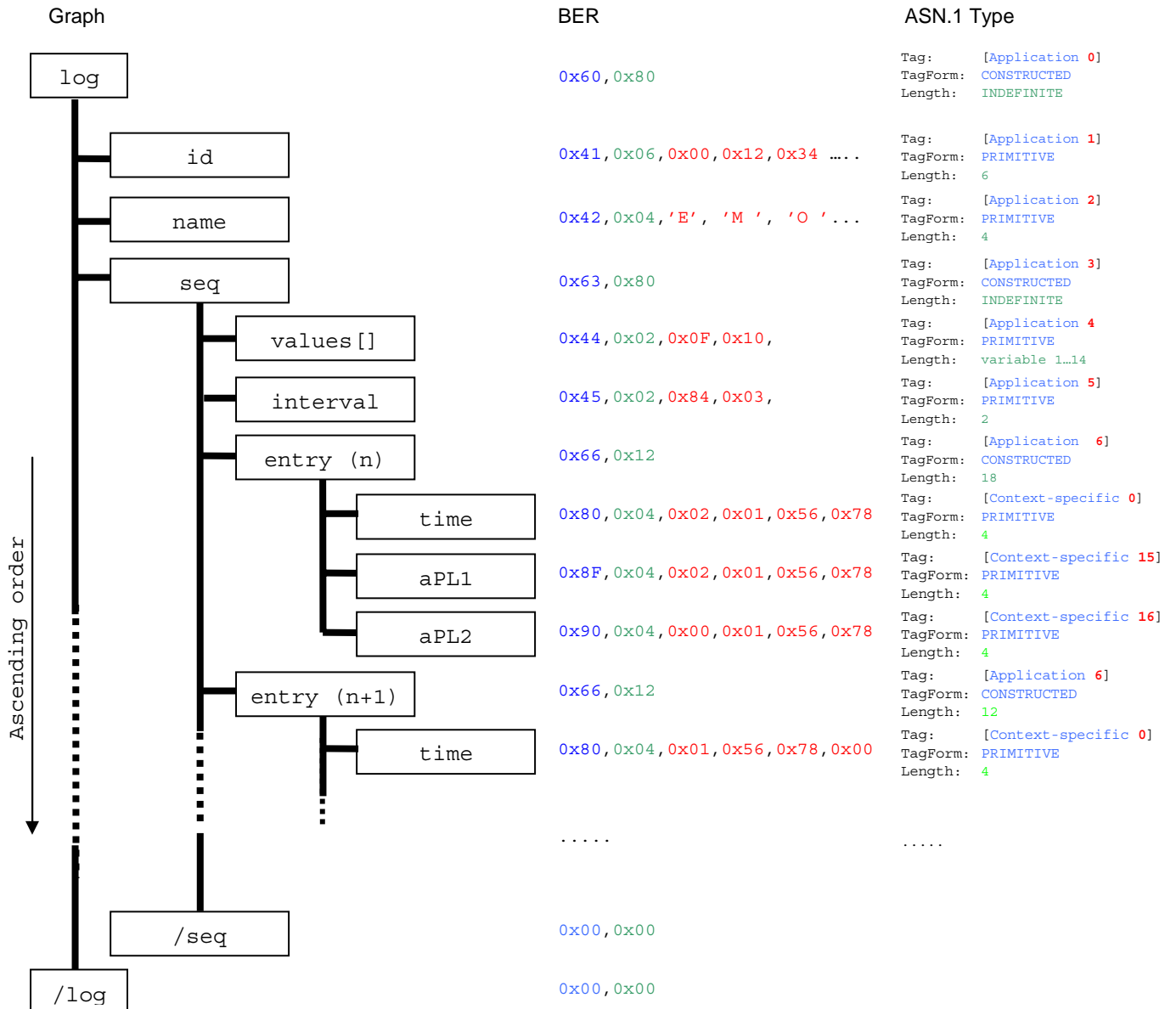

Deleting logger data

Register	Meaning	Values
970	Reset	Bit 0 set: All logged data will be deleted Bit 1 set: Interval timer will be restarted (for internal synchronization only)

Modification	Date	Vis.:	Type: EMMOD203	Nr.: 10 / 24	gez.: 10.05.05 RR
			Description: Definition Modbus/TCP interface	Zeichnr.:	W2416e

3.6 Measurands overflow

Measurands U,I,P,Q,S

The device is designed for a specific rated voltage resp. rated current. If the allowed ranges are exceeded more than 20% the device will display **"oL"** (Overload). A request for appropriate measurands will then be answered with a special data value (9.99*10E30). This will happen for voltage and current measurands as well as for derived power values. There is no specific handling for under- or overflow. Always the same positive overflow value is used.

The same procedure is used for the corresponding minimum, maximum and mean values of these measurands.

Measurand F

For frequency measurement the allowed range is 45.00...65.00Hz. If frequency is not measurable, i.e. if input values are too small or if frequency is not within the allowed range, the appropriate measurand will be barely below 45Hz or barely above 65Hz. On the display a flashing "44.99" resp. "65.01" will be shown.

The same procedure is used for the corresponding minimum, maximum or mean values of the frequency.

Measurand PF

The power factor PF is normally within the range -1.00 .. 1.00. If the factor is not measurable, i.e. if input values are too small, the device display will show "---". In this case the measurand read will be above or below the possible range.

For the minimum values of the power factor the display "---" is shown, if there was no measurand within the supervised quadrant up to now. A measurand request will be answered with the value "1.2".

Measurands THD, harmonic contents, unbalance factor

These percent values are normally within the range 0..100%. If there is an overflow the values will remain on the maximum values of 100%. The same procedure is used for the corresponding minimum, maximum and mean values.

Modification	Date	Vis.:	Type:	EMMOD203	Nr.: 11 / 24	gez.: 10.05.05 RR
			Description:	Definition Modbus/TCP interface	Zeichnr.:	W2416e

4. Status interrogation / remote control

The Ethernet interface allows to request information about presettings or device states. There is also the possibility to control functions like tariff switching, digital output driving or synchronization via this interface.

All these functions are provided by reading or setting register 400. When using the remote control facility more than one task may be transmitted with one command. Subsequent commands don't have to consider the previous state of register 400.

4.1 Status interrogation

Register	Bit	15	14	13	12	11	10	9	8	7	6	5	4	3	2	1	0
400											O2	O1			HL		

HL: Present active tariff situation (0=high tariff, 1=low tariff)

O1: Present state of digital output 1 (0=OFF, 1=ON)

O2: Present state of digital output 2 (0=OFF, 1=ON)

The states of the digital outputs are tracked only, if the outputs are configured for alarm limit monitoring.

4.2 Remote control of digital outputs

Register	Bit	15	14	13	12	11	10	9	8	7	6	5	4	3	2	1	0
400			O2	O1				E2	E1								

The state of the digital outputs may be set via bus interface. This way e.g. the following functions may be performed:

- Test ob subsequent equipment during installation
- On-site alarming via digital outputs, independent of the device function

To perform these tasks it must be assured, that digital outputs are configured for bus control. Therefore it may be necessary to temporary deactivate the configured function of the digital outputs, by setting the most significant bit of the parameter `Diga_Konfig[0]` resp. `Diga_Konfig[1]` (see chapter 6).

- Output 1** E1: Set state of digital output 1 (0=no, 1=yes)
O1: Desired state of digital output 1 (0=OFF, 1=ON)
- Output 2** E2: Set state of digital output 2 (0=no, 1=yes)
O2: Desired state of digital output 2 (0=OFF, 1=ON)

4.3 Setting tariff situation

Register	Bit	15	14	13	12	11	10	9	8	7	6	5	4	3	2	1	0
400						EN	HL										

HL: Desired tariff situation (0=high tariff, 1=low tariff)

EN: Set state of tariff situation (0=no, 1=yes)

4.4 Synchronization via bus interface

Register	Bit	15	14	13	12	11	10	9	8	7	6	5	4	3	2	1	0
400														SY			

The synchronization for the calculation of the mean-power values may be performed via bus interface as well. To do so, the digital input may not be configured for synchronization. Additionally bits 0..5 of the configuration byte `EnergyControl` must be set to 0 to deactivate internal synchronization.

To transmit a synchronization pulse you have to set bit 'SY' of register 400. For logical reasons this command should be sent as a broadcast message (to all devices). To make this a useful application the presence of a master is required all the time.

Modification	Date	Vis.:	Type:	EMMOD203	Nr.: 12 / 24	gez.: 10.05.05	RR
			Description:	Definition Modbus/TCP interface	Zeichnr.:	W2416e	

4.5 Firmware versions and device type

Register address	Measurand	Example
402	Firmware version basic device	214 = Version 02.14
403	Firmware version extension module	102 = Version 01.02
404	Hardware range limit current input	100=1A, 500=5A
405	Hardware range limit voltage input	100=100V, 500=500V
406	Calibration frequency	1 = 16 2/3 Hz 2 = 50 Hz 4 = 60 Hz 8 = 400 Hz

Register address	Measurand	Example
410..412	Device type (string)	"A210\0"

Modification	Date	Vis.:	Type: EMMOD203	Nr.: 13 / 24	gez.: 10.05.05 RR
			Description: Definition Modbus/TCP interface	Zeichnr.:	W2416e

5. Resetting measurands

The power monitoring device contains information considering the progression of measurands in time. Especially these are minimum / maximum values and meters. All these values may be reset independently or all at the same time.

5.1 Resetting minimum and maximum values

The existing values may be influenced in groups. To reset one of these groups the appropriate bit in the register must be set. You may use broadcast messages (address 0) to reset all devices connected to the bus and all selected measurand groups at the same time.

Register	Measurands	Bit	
430	Ux_max	0	
	Ix_max	1	
	Ix_avg_max	2	
	Px_max	3	
	Qx_max	4	
	Sx_max	5	
	Ux_min	6	
	PF_min (Incoming + outgoing)	7	
	unb.U max	¹⁾ 8	
	THD Ux max	¹⁾ 9	
	THD Ix max	¹⁾ 10	
	Harmonics Ux max	¹⁾ 11	
	Harmonics Ix max	¹⁾ 12	
	F_min, F_max	¹⁾ 13	
431	Mean_values Pint max	¹⁾ 0	Incoming
	Mean_values Qint max	¹⁾ 1	Inductive / Incoming
	Mean_values Sint max	¹⁾ 2	
	Mean_values Pint max	¹⁾ 3	Outgoing
	Mean_values Qint max	¹⁾ 4	Capacitive / Outgoing
	conf. Mean_value 1 max	¹⁾ 5	
	conf. Mean_value 2 max	¹⁾ 6	
	conf. Mean_value 3 max	¹⁾ 7	
	conf. Mean_value 4 max	¹⁾ 8	
	conf. Mean_value 5 max	¹⁾ 9	
	conf. Mean_value 6 max	¹⁾ 10	
	conf. Mean_value 7 max	¹⁾ 11	
	conf. Mean_value 8 max	¹⁾ 12	
	conf. Mean_value 9 max	¹⁾ 13	
432	Mean_values Pint min	¹⁾ 0	Incoming
	Mean_values Qint min	¹⁾ 1	Inductive / Incoming
	Mean_values Sint min	¹⁾ 2	
	Mean_values Pint min	¹⁾ 3	Outgoing
	Mean_values Qint min	¹⁾ 4	Capacitive / Outgoing
	conf. Mean_value 1 min	¹⁾ 5	
	conf. Mean_value 2 min	¹⁾ 6	
	conf. Mean_value 3 min	¹⁾ 7	
	conf. Mean_value 4 min	¹⁾ 8	
	conf. Mean_value 5 min	¹⁾ 9	
	conf. Mean_value 6 min	¹⁾ 10	
	conf. Mean_value 7 min	¹⁾ 11	
	conf. Mean_value 8 min	¹⁾ 12	
	conf. Mean_value 9 min	¹⁾ 13	

¹⁾ For A230 only

All bits set will be automatically reset by the device itself as soon as the function completes.

Note: If broadcast messages are used (to all devices) you will receive no acknowledgment.

Modification	Date	Vis.:	Type: EMMOD203	Nr.: 14 / 24	gez.: 10.05.05 RR
			Description: Definition Modbus/TCP interface	Zeichnr.:	W2416e

5.2 Setting / resetting meters

Meters can be independently set to zero or all at the same time. They may be set to any desired content as well. This way you can take over existing meter contents for newly installed devices.

Resetting

To reset meters for each value to reset the appropriate bit in the register must be set.

Register address	Bit	No tariff switching	Tariff switching activated
420	0	P _{incoming}	P _{incoming} HT
	1	-	P _{incoming} LT
	2	P _{outgoing}	P _{outgoing} HT
	3	-	P _{outgoing} LT
	4	Q _{inductive / incoming}	Q _{inductive / incoming} HT
	5	-	Q _{inductive / incoming} LT
	6	Q _{capacitive / outgoing}	Q _{capacitive / outgoing} HT
	7	-	Q _{capacitive / outgoing} LT

The active reactive power meters for the A230 arise from the configuration in 'Disp_Mode' (see chapter 6).

Setting

The same registers will be used as for meter readings.

Register address	No tariff switching	Tariff switching activated
300	P _{incoming}	P _{incoming} HT
302	-	P _{incoming} LT
304	P _{outgoing}	P _{outgoing} HT
306	-	P _{outgoing} LT
308	Q _{inductive}	Q _{inductive} HT
310	-	Q _{inductive} LT
312	Q _{capacitive}	Q _{capacitive} HT
314	-	Q _{capacitive} LT

The active reactive power meters for the A230 arise from the configuration in 'Disp_Mode' (see chapter 6).

Unit factor (read only)

Register address	No tariff switching	Tariff switching activated
320	Unit factor x	

All meter contents are unsigned 32-bit integer numbers (2 registers for each value). These values refer to the significant numbers, which will be displayed on the display unit itself.

The unit factor is an unsigned 16-bit integer number. It is used to scale the meter contents to the appropriate physical unit and to define the number of post decimal positions (see chapter 3.3). This factor is valid for all meter contents of a device and can't be modified.

Modification	Date	Vis.:	Type:	EMMOD203	Nr.: 15 / 24	gez.: 10.05.05 RR
			Description:	Definition Modbus/TCP interface	Zeichnr.:	W2416e

6. Configuration

The power monitoring device may be adjusted to changed conditions on-site by modifying its parameter. The configuration may be performed on register base or block oriented. The information provided within this chapter may not be sufficient to make an independent configuration software. However, the described parameters allow to interpret the configuration read.

Register	Variable	Type	Range	Description
500	Pulsrate[0]	int	0...5000	Rate of pulse output 1 (Pulses / xWvarh)
501	Pulsrate[1]	int	0...5000	Rate of pulse output 2 (Pulses / xWvarh)
502	UPrimAnz	int	100...999	¹⁾ Primary voltage ext. voltage transformer
503	USekAnz	int	100...999	²⁾ Secondary voltage ext. voltage transformer
504	IPrimAnz	int	100...999	³⁾ Primary current ext. current transformer
505	ISekAnz	int	100...999	⁴⁾ Secondary current ext. current transformer
506	UPrimPot	char	0...+3	¹⁾ Decimal power for primary voltage of the external voltage transformer
	USekPot	char	0	²⁾ Decimal power for secondary voltage of the external voltage transformer
507	IPrimPot	char	-2...+3	³⁾ Decimal power for primary current of the external current transformer
	ISekPot	char	-2	⁴⁾ Decimal power for secondary current of the external current transformer
508	COM_Address	BYTE	1...247	⁵⁾ Device address
	COM_Konfig	BYTE	see table	Baudrate, Parity (Modbus RTU only)
509..532	COM_Info[0..47]	char	ASCII	Device description text
533	Diga_GW_close[0]	int	-12000...12000	Alarm limit ON digital output 1
534	Diga_GW_close[1]	int	-12000...12000	Alarm limit ON digital output 2
535	Diga_GW_open[0]	int	-12000...12000	Alarm limit OFF digital output 1
536	Diga_GW_open[1]	int	-12000...12000	Alarm limit OFF digital output 2
537	Anz_Hell	BYTE	0...12	Display brightness
	System	BYTE	see table	System
538	Bild_Nr	char	see table	No. of displayed measurands combination
	Diga_Konfig[0]	BYTE	see table	configuration digital output 1
539	Diga_Konfig[1]	BYTE	see table	configuration digital output 2
	Energy_Control	BYTE	see table	Synchronization + tariff switching
540	Logger_Mode	WORD	see table	Logger: Operating mode, Measurands to log
541	Rated_Freq	BYTE	see table	⁶⁾ Rated frequency
	Disp_Mode	BYTE	see table	⁶⁾ Display mode, Display interval
542..552	Loop_Flag[0..21]	BYTE	see table	⁶⁾ Displayed measurands in loop mode
553..563	User_Flag[0..21]	BYTE	see table	⁶⁾ Displayed measurands in user mode
564	Mean_Log	WORD	see table	⁶⁾ Additional measurands to be logged
565..569	Mean_Meas[9]	BYTE	see table	⁶⁾ Measurands of additional mean values
	Reserve[1]	BYTE		(Completion of register 569, value 0)

1) Range: $100 \dots 999 * 10^{U_{PrimPot}} V_{LL}$ resp. $100V \dots 999kV$

2) Range: $100 \dots 999 * 10^{U_{PrimPot}} V_{LL}$ resp. $100V \dots 999V$

3) Range: $100 \dots 999 * 10^{I_{PrimPot}} A$ resp. $1.00A \dots 999kA$

4) Range: $100 \dots 999 * 10^{I_{SekPot}} A$ resp. $1.00A \dots 9,99A$

5) Configuration via RS232 interface only

6) For A230 only

Modification	Date	Vis.:	Type:	EMMOD203	Nr.: 16 / 24	gez.: 10.05.05 RR
			Description:	Definition Modbus/TCP interface	Zeichnr.:	W2416e

BYTE System

Reg.	Bit	Function	Coding
537 (high)	4..0	Single phase system	xxx00000
		3-wire system, balanced load	xxx00001
		4-wire system, balanced load	xxx00010
		3-wire system, asymmetrical	xxx10011
		3-wire system, asymmetrical (Aron)	xxx00011
		4-wire system, asymmetrical	xxx00100
		4-wire system, asymmetrical (Open-Y)	xxx10100

BYTE Disp_Mode

Reg.	Bit	Function	Coding
541 (low)	1..0	Display mode Full (all possible measurands)	xxxxxx00
		Display mode User (selected part of possible measurands)	xxxxxx01
		Display mode Loop (selected part with periodical change)	xxxxxx10
	2	Display mode lock (L=1)	xxxxLxx
	6..3	Display time in Loop mode 2..32[s] (0000=2s, 1111=32s)	xTTTxxx
7	Mean values + meters basing on measurand Qx (A230 only)		
	Evaluation of Q inductive + Q capacitive	0xxxxxxx	
	Evaluation of Q incoming + Q outgoing	1xxxxxxx	

For A210 / A220 Bit 7 is always set to 0 (Q inductive + Q capacitive)

BYTE Rated_Freq

If Bit 7 is set, input sampling is performed based on the rated frequency set.

Reg.	Bit	Function	Coding
541 (high)	3..0	Rated frequency	xxxx0001 = 16 2/3 Hz (*)
			xxxx0010 = 50 Hz
			xxxx0100 = 60 Hz
		xxxx1000 = 400 Hz (*)	
		(*) not supported yet	
	6..4	not used	x000xxxx
	7	Use rated frequency for sampling	0xxxxxxx No 1xxxxxxx Yes

BYTE Energy_Control

Reg.	Bit	Function	Coding
539 (high)	5...0	Synchronization interval	xx000000 : Remote control via interface 0xyyyyyy : yy=1..60 [min] (internally)
	7...6	Digital input function	x1xxxxxx : Tariff switching via digital input x0xxxxxx : Tariff switching inactive 1zzzzzzz : Synchronization via digital input (zzzzzz may not be 0)

Modification	Date	Vis.:	Type: EMMOD203	Nr.: 17 / 24	gez.: 10.05.05 RR
			Description: Definition Modbus/TCP interface	Zeichnr.:	W2416e

BYTE Diga_Konfig[2] (Reg. 538 high, Reg. 539 low)

- Digital output: Configuration for alarm monitoring

Value	Measurand	A210/A220	A230	single line, 3/4L bal.	3-wire asymmetr.	4-wire asymmetr.
0	Current	•	•	I	I	I
1	Average current	•	•	I.avg	I.avg	I.avg
2	Phase-to-phase voltage	•	•	-	U.LL	U.LL
3	Phase-neutral voltage	•	•	U	-	U.LN
4	Active power	•	•	P	P	P
5	Reactive power	•	•	Q	Q	Q
6	Apparent power	•	•	S	S	S
7	Power factor	•	•	PF	PF	PF
8	P interval	(inc.-outg.)	•	P.int	P.int	P.int
9	Q interval	(ind.+capac.)	1)	Q.int	Q.int	Q.int
10	S interval	•	•	S.int	S.int	S.int
11	Neutral current	•	•	-	-	in
12	Frequency	•	•	F	F	F
13	THD voltage	-	2)	THD.U	THD.LL	THD.LN
14	THD current	-	2)	THD.I	THD.I	THD.I
15	zero displacement voltage	-	2)	-	-	U.NE
16	Unbalanced factor	-	2)	-	-	unb.U
17	P Interval Incoming	-	2)	P.int	P.int	P.int
18	Q Interval cap./Outgoing	-	1)2)	Q.int	Q.int	Q.int
19	P Interval Incoming Trend	-	2)	P.int	P.int	P.int
20	Q Interval ind./Inc. Trend	-	1)2)	Q.int	Q.int	Q.int
21	S Interval Trend	-	2)	S.int	S.int	S.int
22	P Interval Outgoing Trend	-	2)	P.int	P.int	P.int
23	Q Interval cap./Outg. Trend	-	1)2)	Q.int	Q.int	Q.int
24-63	Reserved					

Line measurands: Will be OR-combined for ON limit, resp. AND-combined for OFF limit.

Example for I (ON limit > OFF limit): Limit output to "ON", if one of the 3 phase currents exceeds the ON limit and "OFF" if all phase currents are below the OFF limit.

Example for I (ON limit < OFF limit): Limit output to "ON", if one of the 3 phase currents falls below the ON limit and "OFF" if all phase currents exceed the OFF limit.

1) Which reactive power intervals are active for the A230 arise from the configuration in 'Disp_Mode'.

2) For A230 only

Modification	Date	Vis.:	Type: EMMOD203	Nr.: 18 / 24	gez.: 10.05.05 RR
			Description: Definition Modbus/TCP interface	Zeichnr.:	W2416e

BYTE Diga_Konfig[2] (Reg. 538 high, Reg. 539 low)

- Digital output: Configuration for pulse output

Value	Measurand	A210/A220	A230	Pulses per ...
64	Active energy HT	Incoming	Incoming	Pulses per Wh
65				Pulses per kWh
66				Pulses per MWh
67				Pulses per GWh
68	Active energy LT	Incoming	Incoming	Pulses per Wh
69				Pulses per kWh
70				Pulses per MWh
71				Pulses per GWh
72	Active energy HT	Outgoing	Outgoing	Pulses per Wh
73				Pulses per kWh
74				Pulses per MWh
75				Pulses per GWh
76	Active energy LT	Outgoing	Outgoing	Pulses per Wh
77				Pulses per kWh
78				Pulses per MWh
79				Pulses per GWh
80	Reactive energy HT	inductive	1) inductive/incoming	Pulses per varh
81				Pulses per kvarh
82				Pulses per Mvarh
83				Pulses per Gvarh
84	Reactive energy LT	inductive	1) inductive/incoming	Pulses per varh
85				Pulses per kvarh
86				Pulses per Mvarh
87				Pulses per Gvarh
88	Reactive energy HT	capacitive	1) capacitive/outgoing	Pulses per varh
89				Pulses per kvarh
90				Pulses per Mvarh
91				Pulses per Gvarh
92	Reactive energy LT	capacitive	1) capacitive/outgoing	Pulses per varh
93				Pulses per kvarh
94				Pulses per Mvarh
95				Pulses per Gvarh
96..127	Reserved			
>127	No function or remote control via bus interface			

HT=High tariff, LT=Low tariff

1) Which reactive energy pulse output is active for the A230 arises from the configuration in 'Disp_Mode'.

If the digital input isn't configured for tariff-switching, only high tariff meters will be served. Exception: Low tariff is commanded via bus interface.

Modification	Date	Vis.:	Type:	EMMOD203	Nr.: 19 / 24	gez.: 10.05.05 RR
			Description:	Definition Modbus/TCP interface	Zeichnr.:	W2416e

WORD Logger_Mode (Reg. 540)

Selection of logger operating mode and mean-power measurands to log

Bit	Function	A210 / A220	A230
9	0: Logger one-time recording stops if buffer is full 1: Logger endless oldest value will be deleted if buffer is full		
10	1: Q interval will be logged	Qind + Qcap	Qind / Qinc (Inc.)
11	1: P interval will be logged	Pinc + Pout	Pinc (Inc.)
12	1: Q interval will be logged	-	Qcap / Qout (Outg.)
13	1: P interval will be logged	-	Pout (Outg.)
14	1: S interval will be logged	-	S

WORD Mean_Log (A230 only)

Selection if chosen mean-values (Mean_Meas[0..8]) should be logged.

Reg.	Bit	Recording measurand...
564	0	Mean_Meas[0]
	1	Mean_Meas[1]
	2	Mean_Meas[2]
	3	Mean_Meas[3]
	4	Mean_Meas[4]
	5	Mean_Meas[5]
	6	Mean_Meas[6]
	7	Mean_Meas[7]
	8	Mean_Meas[8]

BYTE Mean_Meas[9] (A230 only) (Reg. 565...Reg.569 low)

For the mean value measurands selected here the last evaluated value and the trend for the present interval can be interrogated via bus interface. Not used measurands should be set to 255.

Value	Measurand	1-line, 3/4L bal.	3 wire unbal.	4 wire unbal.	Value	Measurand	1-line, 3/4L bal.	3 wire unbal.	4 wire unbal.
0	U	☉	-	-	63	Q2 cap/out	-	-	☉
0	U1N	-	-	☉	64	Q3 cap/out	-	-	☉
1	U2N	-	-	☉	21	S1	-	-	☉
2	U3N	-	-	☉	22	S2	-	-	☉
3	U12	-	☉	☉	23	S3	-	-	☉
4	U23	-	☉	☉	25	f	☉	☉	☉
5	U31	-	☉	☉	29	PF	☉	☉	☉
6	I	☉	-	-	26	PF1	-	-	☉
6	I1	-	☉	☉	27	PF2	-	-	☉
7	I2	-	☉	☉	28	PF3	-	-	☉
8	I3	-	☉	☉	31	U mean	-	☉	☉
12	IN	-	-	☉	32	I mean	-	☉	☉
50	P1 inc	-	-	☉	33	UNE	-	-	☉
51	P2 inc	-	-	☉	39	unb.U	-	-	☉
52	P3 inc	-	-	☉	40	THD U	☉	-	-
54	P1 out	-	-	☉	40	THD U1	-	U12	U1
55	P2 out	-	-	☉	41	THD U2	-	U23	U2
56	P3 out	-	-	☉	42	THD U3	-	U31	U3
58	Q1 ind/inc	-	-	☉	43	THD I	☉	-	-
59	Q2 ind/inc	-	-	☉	43	THD I1	-	☉	☉
60	Q3 ind/inc	-	-	☉	44	THD I2	-	☉	☉
62	Q1 cap/out	-	-	☉	45	THD I3	-	☉	☉

1) Which reactive power measurands are active arise from the configuration in 'Disp_Mode'.

Modification	Date	Vis.:	Type:	EMMOD203	Nr.: 20 / 24	gez.: 10.05.05 RR
			Description:	Definition Modbus/TCP interface	Zeichnr.:	W2416e

BYTE Loop_Flag[22] (Reg. 542...552)

BYTE User_Flag[22] (Reg. 553...563)

Each display of the matrices for the loop and user mode shown in the appendix can be selected either to be displayed (Bit set) or not to be displayed (Bit not set). The following table shows the assignment of the display fields to the bits and bytes of the configuration registers. Not used or not usable bits must be set to zero.

Byte	Bit	Display field			Byte	Bit	Display field			Byte	Bit	Display field			Byte	Bit	Display field		
		1Ph	3LU	4LU			1Ph	3LU	4LU			1Ph	3LU	4LU			1Ph	3LU	4LU
0	0	1-a	1-a	1-a	6	0	16-e	15-d	13-b	12	0	20-c	19-l	18	0	23-i	23-d		
	1	2-a	1-b	1-b		1	16-f	15-e	13-c		1	20-d	19-m		1	23-j	23-e		
	2	2-b	1-c	1-c		2	16-g	15-f	14-a		2	20-e	19-n		2	23-k	23-f		
	3	3-a	2-a	1-d		3	17-a	15-g	14-b		3	20-f	20-a		3	23-l	23-g		
	4	4-a	2-b	1-e		4	17-b	16-a	14-c		4	20-g	20-b		4	23-m	23-h		
	5	5-a	2-c	1-f		5	17-c	16-b	14-d		5	20-h	20-c		5	23-n	23-i		
	6	6-a	2-d	1-g		6	17-d	16-c	14-e		6	20-i	20-d		6	23-o	23-j		
	7	6-b	3-a	1-h		7	17-e	16-d	14-f		7	20-j	20-e		7	23-p	23-k		
1	0	7-a	4-a	2-a	7	0	17-f	16-e	14-g	13	0	20-k	20-f	19	0	23-q	23-l		
	1	8-a	5-a	2-b		1	17-g	16-f	15-a		1	20-l	20-g		1	23-r	23-m		
	2	8-b	6-a	2-c		2	18-a	16-g	15-b		2	20-m	20-h		2	23-s	23-n		
	3	8-c	6-b	2-d		3	18-b	17-a	15-c		3	20-n	20-i		3	23-t	24-a		
	4	8-d	7-a	2-e		4	18-c	17-b	15-d		4	21-a	20-j		4	23-u	24-b		
	5	9-a	8-a	3-a		5	18-d	17-c	15-e		5	21-b	20-k		5	23-v	24-c		
	6	9-b	8-b	3-b		6	18-e	17-d	15-f		6	21-c	20-l		6	23-w	24-d		
	7	9-c	8-c	3-c		7	18-f	17-e	15-g		7	21-d	20-m		7	23-x	24-e		
2	0	9-d	8-d	4-a	8	0	18-g	17-f	16-a	14	0	21-e	20-n	20	0	23-y	24-f		
	1	10-a	9-a	4-b		1	18-h	17-g	16-b		1	21-f	21-a		1	23-z	24-g		
	2	10-b	9-b	4-c		2	18-i	18-a	16-c		2	21-g	21-b		2	24-a	24-h		
	3	10-c	9-c	5-a		3	18-j	18-b	16-d		3	21-h	21-c		3	24-b	24-i		
	4	10-d	9-d	5-b		4	18-k	18-c	16-e		4	21-i	21-d		4	24-c	24-j		
	5	11-a	10-a	5-c		5	18-l	18-d	16-f		5	21-j	21-e		5	24-d	24-k		
	6	12-a	10-b	6-a		6	18-m	18-e	16-g		6	21-k	21-f		6	24-e	24-l		
	7	13-a	10-c	6-b		7	18-n	18-f	17-a		7	21-l	21-g		7	24-f	24-m		
3	0	13-b	10-d	6-c	9	0	19-a	18-g	17-b	15	0	21-m	21-h	21	0	24-g	24-n		
	1	13-c	11-a	7-a		1	19-b	18-h	17-c		1	21-n	21-i		1	24-h	24-o		
	2	13-d	11-b	8-a		2	19-c	18-i	17-d		2	22-a	21-j		2	24-i	24-p		
	3	13-e	11-c	8-b		3	19-d	18-j	17-e		3	22-b	21-k		3	24-j	24-q		
	4	13-f	12-a	8-c		4	19-e	18-k	17-f		4	22-c	21-l		4	24-k	24-r		
	5	13-g	12-b	8-d		5	19-f	18-l	17-g		5	22-d	21-m		5	24-l	24-s		
	6	14-a	12-c	9-a		6	19-g	18-m	18-a		6	22-e	21-n		6	24-m	24-t		
	7	14-b	13-a	9-b		7	19-h	18-n	18-b		7	22-f	22-a		7	24-n	24-u		
4	0	14-c	13-b	9-c	10	0	19-i	19-a	18-c	16	0	22-g	22-b						
	1	14-d	13-c	9-d		1	19-j	19-b	18-d		1	22-h	22-c						
	2	14-e	13-d	10-a		2	19-k	19-c	18-e		2	22-i	22-d						
	3	14-f	13-e	10-b		3	19-l	19-d	18-f		3	22-j	22-e						
	4	14-g	13-f	10-c		4	19-m	19-e	18-g		4	22-k	22-f						
	5	15-a	13-g	10-d		5	19-n	19-f	19-a		5	22-l	22-g						
	6	15-b	14-a	11-a		6		19-g	19-b		6	22-m	22-h						
	7	15-c	14-b	11-b		7		19-h	19-c		7	22-n	22-i						
5	0	15-d	14-c	11-c	11	0		19-i	19-d	17	0	23-a	22-j						
	1	15-e	14-d	11-d		1		19-j	19-e		1	23-b	22-k						
	2	15-f	14-e	11-e		2		19-k	19-f		2	23-c	22-l						
	3	15-g	14-f	11-f		3		19-l	19-g		3	23-d	22-m						
	4	16-a	14-g	12-a		4		19-m	19-h		4	23-e	22-n						
	5	16-b	15-a	12-b		5		19-n	19-i		5	23-f	23-a						
	6	16-c	15-b	12-c		6		20-a	19-j		6	23-g	23-b						
	7	16-d	15-c	13-a		7		20-b	19-k		7	23-h	23-c						

1Ph: Single phase system, 3/4 wire balanced load / **3LU:** 3-wire, unbalanced load / **4LU:** 4-wire, unbalanced load

Modification	Date	Vis.:	Type:	EMMOD203	Nr.: 21 / 24	gez.: 10.05.05 RR
			Description:	Definition Modbus/TCP interface	Zeichnr.:	W2416e

Appendix: Display matrices, system dependent

Display matrix for 4-wire, unbalanced load system

	a	b	c	d	e	f	g	h
1	U1 U2 U3	U1max U2max U3max	U1min U2min U3min	U12 U23 U31	U12max U23max U31max	U12min U23min U31min	UNE UNEmax	unb.U unb.Umax
2	I1 I2 I3	I1max I2max I3max	I1avg I2avg I3avg	I1avgmax I2avgmax I3avgmax	IN INmax			
3	P1 P2 P3	P1max P2max P3max	P Pmax					
4	Q1 Q2 Q3	Q1max Q2max Q3max	Q Qmax					
5	S1 S2 S3	S1max S2max S3max	S Smax					
6	PF1 PF2 PF3	PF PFmin.inc.ind PFmin.inc.cp	PF PFmin.out.ind PFmin.out.cp					
7	Fmax F Fmin							
8	EPinc HT	EPinc LT	EPout HT	EPout LT				
9	EQ inc/ind HT	EQ inc/ind LT	EQ out/cap HT	EQ out/cap LT				
10	P Q S	U Ø I Ø P	PF P Q	P S F				
11	P1 Q1 S1	P2 Q2 S2	P3 Q3 S3	U1 I1 P1	U2 I2 P2	U3 I3 P3		
12	thd.U1 thd.U1max	thd.U2 thd.U2max	thd.U3 thd.U3max					
13	thd.I1 thd.I1max	thd.I2 thd.I2max	thd.I3 thd.I3max					
14	P.inc-int.Trend	P.inc-int.max P.inc-int.min	P.inc-int -0	P.inc-int -1	P.inc-int -2	P.inc-int -3	P.inc-int -4	
15	P.out-int.Trend	P.out-int.max P.out-int.min	P.out-int -0	P.out-int -1	P.out-int -2	P.out-int -3	P.out-int -4	
16	Q.inc/ind-int.Trend	Q.inc/ind-int.max Q.inc/ind-int.min	Q.inc/ind-int -0	Q.inc/ind-int -1	Q.inc/ind-int -2	Q.inc/ind-int -3	Q.inc/ind-int -4	
17	Q.out/cap-int.Trend	Q.out/cap-int.max	Q.out/cap-int -0	Q.out/cap-int -1	Q.out/cap-int -2	Q.out/cap-int -3	Q.out/cap-int -4	
18	S.int.Trend	S.int.max S.int.min	S.int -0	S.int -1	S.int -2	S.int -3	S.int -4	

inc/ind
out/cap

Depending on the Q-definition in 'Disp_Mode' values for incoming-outgoing resp. inductive-capacitive will be displayed

	a	b	c	d	e	f	g	h	i	j	k	l	m	n
19	H2.U1 H2max.U1	H3.U1 H3max.U1	H4.U1 H4max.U1	H5.U1 H5max.U1	H6.U1 H6max.U1	H7.U1 H7max.U1	H8.U1 H8max.U1	H9.U1 H9max.U1	H10.U1 H10max.U1	H11.U1 H11max.U1	H12.U1 H12max.U1	H13.U1 H13max.U1	H14.U1 H14max.U1	H15.U1 H15max.U1
20	H2.U2 H2max.U2	H3.U2 H3max.U2	H4.U2 H4max.U2	H5.U2 H5max.U2	H6.U2 H6max.U2	H7.U2 H7max.U2	H8.U2 H8max.U2	H9.U2 H9max.U2	H10.U2 H10max.U2	H11.U2 H11max.U2	H12.U2 H12max.U2	H13.U2 H13max.U2	H14.U2 H14max.U2	H15.U2 H15max.U2
21	H2.U3 H2max.U3	H3.U3 H3max.U3	H4.U3 H4max.U3	H5.U3 H5max.U3	H6.U3 H6max.U3	H7.U3 H7max.U3	H8.U3 H8max.U3	H9.U3 H9max.U3	H10.U3 H10max.U3	H11.U3 H11max.U3	H12.U3 H12max.U3	H13.U3 H13max.U3	H14.U3 H14max.U3	H15.U3 H15max.U3
22	H2.I1 H2max.I1	H3.I1 H3max.I1	H4.I1 H4max.I1	H5.I1 H5max.I1	H6.I1 H6max.I1	H7.I1 H7max.I1	H8.I1 H8max.I1	H9.I1 H9max.I1	H10.I1 H10max.I1	H11.I1 H11max.I1	H12.I1 H12max.I1	H13.I1 H13max.I1	H14.I1 H14max.I1	H15.I1 H15max.I1
23	H2.I2 H2max.I2	H3.I2 H3max.I2	H4.I2 H4max.I2	H5.I2 H5max.I2	H6.I2 H6max.I2	H7.I2 H7max.I2	H8.I2 H8max.I2	H9.I2 H9max.I2	H10.I2 H10max.I2	H11.I2 H11max.I2	H12.I2 H12max.I2	H13.I2 H13max.I2	H14.I2 H14max.I2	H15.I2 H15max.I2
24	H2.I3 H2max.I3	H3.I3 H3max.I3	H4.I3 H4max.I3	H5.I3 H5max.I3	H6.I3 H6max.I3	H7.I3 H7max.I3	H8.I3 H8max.I3	H9.I3 H9max.I3	H10.I3 H10max.I3	H11.I3 H11max.I3	H12.I3 H12max.I3	H13.I3 H13max.I3	H14.I3 H14max.I3	H15.I3 H15max.I3

Modification	Date	Vis.:	Type:	EMMOD203	Nr.: 22 / 24	gez.: 10.05.05 RR
			Description:	Definition Modbus/TCP interface	Zeichnr.:	W2416e

Display matrix for 3-wire, unbalanced load system

	a	b	c	d	e	f	g
1	U12 U23 U31	U12max U23max U31max	U12min U23min U31min				
2	I1 I2 I3	I1max I2max I3max	I1avg I2avg I3avg	I1avgmax I2avgmax I3avgmax			
3	P Pmax						
4	Q Qmax						
5	S Smax						
6	PF PFmin.inc.ind PFmin.inc.cp	PF PFmin.out.ind PFmin.out.cp					
7	Fmax F Fmin						
8	EPinc HT	EPinc LT	EPout HT	EPout LT			
9	EQ inc/ind HT	EQ inc/ind LT	EQ out/cap HT	EQ out/cap LT			
10	P Q S	U Ø I Ø P	PF P Q	P S F			
11	thd.U12 thd.U12max	thd.U23 thd.U23max	thd.U31 thd.U31max				
12	thd.I1 thd.I1max	thd.I2 thd.I2max	thd.I3 thd.I3max				
13	P.inc-int.Trend	P.inc-int.max P.inc-int.min	P.inc-int -0	P.inc-int -1	P.inc-int -2	P.inc-int -3	P.inc-int -4
14	P.out-int.Trend	P.out-int.max P.out-int.min	P.out-int -0	P.out-int -1	P.out-int -2	P.out-int -3	P.out-int -4
15	Q.inc/ind-int.Trend	Q.inc/ind-int.max Q.inc/ind-int.min	Q.inc/ind-int -0	Q.inc/ind-int -1	Q.inc/ind-int -2	Q.inc/ind-int -3	Q.inc/ind-int -4
16	Q.out/cap-int.Trend	Q.out/cap-int.max	Q.out/cap-int -0	Q.out/cap-int -1	Q.out/cap-int -2	Q.out/cap-int -3	Q.out/cap-int -4
17	S.int.Trend	S.int.max S.int.min	S.int -0	S.int -1	S.int -2	S.int -3	S.int -4

inc/ind
out/cap

Depending on the Q-definition in 'Disp_Mode' values for incoming-outgoing resp. inductive-capacitive will be displayed

	a	b	c	d	e	f	g	h	i	j	k	l	m	n
18	H2.U12 H2max.U12	H3.U12 H3max.U12	H4.U12 H4max.U12	H5.U12 H5max.U12	H6.U12 H6max.U12	H7.U12 H7max.U12	H8.U12 H8max.U12	H9.U12 H9max.U12	H10.U12 H10max.U12	H11.U12 H11max.U12	H12.U12 H12max.U12	H13.U12 H13max.U12	H14.U12 H14max.U12	H15.U12 H15max.U12
19	H2.U23 H2max.U23	H3.U23 H3max.U23	H4.U23 H4max.U23	H5.U23 H5max.U23	H6.U23 H6max.U23	H7.U23 H7max.U23	H8.U23 H8max.U23	H9.U23 H9max.U23	H10.U23 H10max.U23	H11.U23 H11max.U23	H12.U23 H12max.U23	H13.U23 H13max.U23	H14.U23 H14max.U23	H15.U23 H15max.U23
20	H2.U31 H2max.U31	H3.U31 H3max.U31	H4.U31 H4max.U31	H5.U31 H5max.U31	H6.U31 H6max.U31	H7.U31 H7max.U31	H8.U31 H8max.U31	H9.U31 H9max.U31	H10.U31 H10max.U31	H11.U31 H11max.U31	H12.U31 H12max.U31	H13.U31 H13max.U31	H14.U31 H14max.U31	H15.U31 H15max.U31
21	H2.I1 H2max.I1	H3.I1 H3max.I1	H4.I1 H4max.I1	H5.I1 H5max.I1	H6.I1 H6max.I1	H7.I1 H7max.I1	H8.I1 H8max.I1	H9.I1 H9max.I1	H10.I1 H10max.I1	H11.I1 H11max.I1	H12.I1 H12max.I1	H13.I1 H13max.I1	H14.I1 H14max.I1	H15.I1 H15max.I1
22	H2.I2 H2max.I2	H3.I2 H3max.I2	H4.I2 H4max.I2	H5.I2 H5max.I2	H6.I2 H6max.I2	H7.I2 H7max.I2	H8.I2 H8max.I2	H9.I2 H9max.I2	H10.I2 H10max.I2	H11.I2 H11max.I2	H12.I2 H12max.I2	H13.I2 H13max.I2	H14.I2 H14max.I2	H15.I2 H15max.I2
23	H2.I3 H2max.I3	H3.I3 H3max.I3	H4.I3 H4max.I3	H5.I3 H5max.I3	H6.I3 H6max.I3	H7.I3 H7max.I3	H8.I3 H8max.I3	H9.I3 H9max.I3	H10.I3 H10max.I3	H11.I3 H11max.I3	H12.I3 H12max.I3	H13.I3 H13max.I3	H14.I3 H14max.I3	H15.I3 H15max.I3

Modification	Date	Vis.:	Type:	EMMOD203	Nr.: 23 / 24	gez.: 10.05.05 RR
			Description:	Definition Modbus/TCP interface	Zeichnr.:	W2416e

Display matrix for single line and 3/4-wire balanced load systems

	a	b	c	d	e	f	g
1	U _{max} U U _{min}						
2	I I _{max}	I _{avg} I _{avgmax}					
3	P P _{max}						
4	Q Q _{max}						
5	S S _{max}						
6	PF PF _{min.inc.ind} PF _{min.inc.cp}	PF PF _{min.out.ind} PF _{min.out.cp}					
7	F _{max} F F _{min}						
8	EP _{inc HT}	EP _{inc LT}	EP _{out HT}	EP _{out LT}			
9	EQ _{inc/ind HT}	EQ _{inc/ind LT}	EQ _{out/cap HT}	EQ _{out/cap LT}			
10	P Q S	U I P	PF P Q	P S F			
11	thd.U thd.U _{max}						
12	thd.I thd.I _{max}						
13	P _{.inc-int.Trend}	P _{.inc-int.max} P _{.inc-int.min}	P _{.inc-int -0}	P _{.inc-int -1}	P _{.inc-int -2}	P _{.inc-int -3}	P _{.inc-int -4}
14	P _{.out-int.Trend}	P _{.out-int.max} P _{.out-int.min}	P _{.out-int -0}	P _{.out-int -1}	P _{.out-int -2}	P _{.out-int -3}	P _{.out-int -4}
15	Q _{.inc/ind-int.Trend}	Q _{.inc/ind-int.max} Q _{.inc/ind-int.min}	Q _{.inc/ind-int -0}	Q _{.inc/ind-int -1}	Q _{.inc/ind-int -2}	Q _{.inc/ind-int -3}	Q _{.inc/ind-int -4}
16	Q _{.out/cap-int.Trend}	Q _{.out/cap-int.max}	Q _{.out/cap-int -0}	Q _{.out/cap-int -1}	Q _{.out/cap-int -2}	Q _{.out/cap-int -3}	Q _{.out/cap-int -4}
17	S _{.int.Trend}	S _{.int.max} S _{.int.min}	S _{.int -0}	S _{.int -1}	S _{.int -2}	S _{.int -3}	S _{int -4}

inc/ind
out/cap Depending on the Q-definition in 'Disp_Mode' values for incoming-outgoing resp. inductive-capacitive will be displayed

	a	b	c	d	e	f	g	h	i	j	k	l	m	n
18	H2.u H2 _{max.U}	H3.u H3 _{max.U}	H4.u H4 _{max.U}	H5.u H5 _{max.U}	H6.u H6 _{max.U}	H7.u H7 _{max.U}	H8.u H8 _{max.U}	H9.u H9 _{max.U}	H10.u H10 _{max.U}	H11.u H11 _{max.U}	H12.u H12 _{max.U}	H13.u H13 _{max.U}	H14.u H14 _{max.U}	H15.u H15 _{max.U}
19	H2.l H2 _{max.l}	H3.l H3 _{max.l}	H4.l H4 _{max.l}	H5.l H5 _{max.l}	H6.l H6 _{max.l}	H7.l H7 _{max.l}	H8.l H8 _{max.l}	H9.l H9 _{max.l}	H10.l H10 _{max.l}	H11.l H11 _{max.l}	H12.l H12 _{max.l}	H13.l H13 _{max.l}	H14.l H14 _{max.l}	H15.l H15 _{max.l}

Modification	Date	Vis.:	Type: EMMOD203	Nr.: 24 / 24	gez.: 10.05.05 RR
			Description: Definition Modbus/TCP interface	Zeichnr.:	W2416e